

# YASKAWA R1000 Series

## Power Regenerative Unit

### Technical Manual

Type: CIMR-R

Models: 200 V Class, Three-Phase Input: 3.5 to 105 kW  
400 V Class, Three-Phase Input: 3.5 to 300 kW

To properly use the product, read this manual thoroughly and retain for easy reference, inspection, and maintenance. Ensure the end user receives this manual.

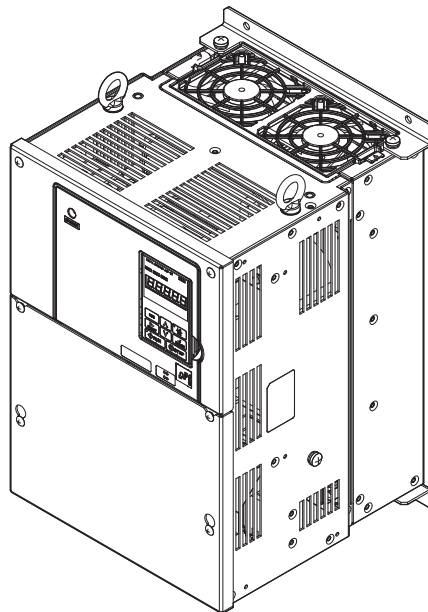

Receiving	1
Mechanical Installation	2
Electrical Installation	3
Start-Up Programming & Operation	4
Troubleshooting	5
Periodic Inspection & Maintenance	6
Standard Configuration Devices, Peripheral Devices, and Options	7
Specifications	A
Parameter List	B
MEMOBUS/Modbus Communications	C
Standards Compliance	D

---

Copyright © 2014 YASKAWA ELECTRIC CORPORATION. All rights reserved.

No part of this publication may be reproduced, stored in a retrieval system, or transmitted, in any form or by any means, mechanical, electronic, photocopying, recording, or otherwise, without the prior written permission of Yaskawa. No patent liability is assumed with respect to the use of the information contained herein. Moreover, because Yaskawa is constantly striving to improve its high-quality products, the information contained in this manual is subject to change without notice. Every precaution has been taken in the preparation of this manual. Yaskawa assumes no responsibility for errors or omissions. Neither is any liability assumed for damages resulting from the use of the information contained in this publication.

# Table of Contents

---

<b>i. PREFACE &amp; GENERAL SAFETY</b> .....	<b>7</b>
<b>i.1 Preface</b> .....	<b>8</b>
Applicable Documentation .....	8
Symbols .....	8
Terms and Abbreviations .....	8
Trademarks .....	8
<b>i.2 General Safety</b> .....	<b>9</b>
Supplemental Safety Information .....	9
Safety Messages .....	10
General Application Precautions .....	12
Precautions on Using Peripheral Devices .....	13
Warning Label Example .....	14
Warranty Information .....	14
<b>1. RECEIVING</b> .....	<b>15</b>
<b>1.1 Section Safety</b> .....	<b>16</b>
<b>1.2 Model Numbers and Nameplates</b> .....	<b>17</b>
Nameplate .....	17
Model Numbers .....	17
<b>1.3 Regenerative Unit Models and Enclosure Types</b> .....	<b>18</b>
<b>2. MECHANICAL INSTALLATION</b> .....	<b>19</b>
<b>2.1 Section Safety</b> .....	<b>20</b>
<b>2.2 Mechanical Installation</b> .....	<b>21</b>
Installation Environment .....	21
Installation Orientation and Spacing .....	21
Precautions and Instructions for Installation .....	23
Digital Operator Remote Usage .....	25
Exterior and Mounting Dimensions .....	26
<b>3. ELECTRICAL INSTALLATION</b> .....	<b>29</b>
<b>3.1 Section Safety</b> .....	<b>30</b>
<b>3.2 Standard Connection Diagram</b> .....	<b>32</b>
<b>3.3 Main Circuit Connection Diagram</b> .....	<b>34</b>
<b>3.4 Terminal Block Configuration</b> .....	<b>35</b>
<b>3.5 Terminal Cover</b> .....	<b>38</b>
Models 2A03P5 to 2A0028, 4A03P5 to 4A0028 (IP20/NEMA Type 1) .....	38
Models 2A0035 to 2A0105, 4A0035 to 4A0300 (IP00/Open Type enclosure) .....	39
<b>3.6 Digital Operator and Front Cover</b> .....	<b>40</b>
Removing/Reattaching the Digital Operator .....	40

	Removing/Reattaching the Front Cover .....	40
<b>3.7</b>	<b>Top Protective Cover .....</b>	<b>42</b>
	Removing and Reattaching the Top Protective Cover .....	42
<b>3.8</b>	<b>Main Circuit Wiring .....</b>	<b>43</b>
	Main Circuit Terminal Functions .....	43
	Protecting Main Circuit Terminals .....	43
	Wire Gauges and Tightening Torque .....	43
	Ground Wiring .....	46
<b>3.9</b>	<b>Control Circuit Wiring .....</b>	<b>48</b>
	Control Circuit Terminal Block Functions .....	49
	Terminal Configuration .....	50
	Wiring the Control Circuit Terminal .....	51
<b>3.10</b>	<b>Control I/O Connections .....</b>	<b>53</b>
	Terminal A2 Input Signal Selection .....	53
	Using the Contact Outputs .....	54
	Connect to a PC .....	54
<b>3.11</b>	<b>Wiring Checklist .....</b>	<b>55</b>
<b>4.</b>	<b>START-UP PROGRAMMING &amp; OPERATION .....</b>	<b>57</b>
<b>4.1</b>	<b>Section Safety .....</b>	<b>58</b>
<b>4.2</b>	<b>Using the Digital Operator .....</b>	<b>59</b>
	LCD Display .....	59
	ALARM (ALM) LED Displays .....	60
	LO/RE LED and RUN LED Indications .....	60
	Menu Structure for Digital Operator .....	61
<b>4.3</b>	<b>The Drive and Programming Modes .....</b>	<b>62</b>
	Navigating the Drive and Programming Modes (Default Setting) .....	62
	Changing Parameter Settings or Values .....	63
	Verifying Parameter Changes: Verify Mode .....	64
	Switching Between LOCAL and REMOTE .....	64
<b>4.4</b>	<b>Powering Up the Regenerative Unit .....</b>	<b>65</b>
	Powering Up the Regenerative Unit and Operation Status Display .....	65
<b>4.5</b>	<b>Operation with the Drive Connected .....</b>	<b>66</b>
	Drive Connection Example .....	66
	Timing Chart for Turning the Power Supply On and Off .....	66
	Operation Command Selection .....	66
	Interlocks .....	68
<b>4.6</b>	<b>Verifying Parameter Settings and Backing Up Changes .....</b>	<b>69</b>
	Backing Up Parameter Values: o2-03 .....	69
	Parameter Access Level: A1-01 .....	69
	Password Settings: A1-04, A1-05 .....	70
	Copy Function .....	70
<b>4.7</b>	<b>Test Run Checklist .....</b>	<b>71</b>
<b>5.</b>	<b>TROUBLESHOOTING .....</b>	<b>73</b>
<b>5.1</b>	<b>Section Safety .....</b>	<b>74</b>
<b>5.2</b>	<b>Alarms, Faults, and Errors .....</b>	<b>75</b>
	Types of Alarms, Faults, and Errors .....	75
	Alarm and Error Displays .....	76
<b>5.3</b>	<b>Fault Detection .....</b>	<b>79</b>
	Fault Displays, Causes, and Possible Solutions .....	79
<b>5.4</b>	<b>Alarm Detection .....</b>	<b>89</b>
	Alarm Codes, Causes, and Possible Solutions .....	89
<b>5.5</b>	<b>Operator Programming Errors .....</b>	<b>96</b>



	Operator Programming Error Codes, Causes, and Possible Solutions . . . . .	96
<b>5.6</b>	<b>Copy Function Related Displays</b> . . . . .	<b>98</b>
	Tasks, Errors, and Troubleshooting . . . . .	98
<b>5.7</b>	<b>Diagnosing and Resetting Faults</b> . . . . .	<b>99</b>
	Fault Reset Methods . . . . .	99
<b>6.</b>	<b>PERIODIC INSPECTION &amp; MAINTENANCE</b> . . . . .	<b>101</b>
<b>6.1</b>	<b>Section Safety</b> . . . . .	<b>102</b>
<b>6.2</b>	<b>Inspection</b> . . . . .	<b>104</b>
	Recommended Daily Inspection . . . . .	104
	Recommended Periodic Inspection . . . . .	104
<b>6.3</b>	<b>Periodic Maintenance</b> . . . . .	<b>106</b>
	Replacement Parts . . . . .	106
<b>6.4</b>	<b>Cooling Fans</b> . . . . .	<b>108</b>
	Number of Cooling Fans . . . . .	108
	Cooling Fan Component Names . . . . .	109
	Cooling Fan Replacement . . . . .	110
<b>6.5</b>	<b>Regenerative Unit Replacement</b> . . . . .	<b>118</b>
	Serviceable Parts . . . . .	118
	Terminal Board . . . . .	118
	Replacing the Regenerative Unit . . . . .	119
<b>7.</b>	<b>STANDARD CONFIGURATION DEVICES, PERIPHERAL DEVICES, AND OPTIONS</b> . . . . .	<b>121</b>
<b>7.1</b>	<b>Section Safety</b> . . . . .	<b>122</b>
<b>7.2</b>	<b>Regenerative Unit Options and Peripheral Devices</b> . . . . .	<b>124</b>
<b>7.3</b>	<b>Connecting Standard Configuration Devices and Peripheral Devices</b> . . . . .	<b>125</b>
<b>7.4</b>	<b>Standard Configuration Devices Wiring</b> . . . . .	<b>126</b>
	Wire Gauges and Tightening Torque . . . . .	126
	Terminal Functions . . . . .	128
	Specification . . . . .	128
<b>7.5</b>	<b>Installing Peripheral Devices</b> . . . . .	<b>130</b>
	Installing a Molded Case Circuit Breaker (MCCB) or Residual Current Device (RCD) . . . . .	130
	Installing a Magnetic Contactor at the Power Supply Side . . . . .	131
	Connecting a Surge Absorber . . . . .	131
	Attachment for External Heatsink Mounting . . . . .	131
<b>A.</b>	<b>SPECIFICATIONS</b> . . . . .	<b>133</b>
<b>A.1</b>	<b>Power Ratings</b> . . . . .	<b>134</b>
<b>A.2</b>	<b>Regenerative Unit Specifications</b> . . . . .	<b>135</b>
<b>A.3</b>	<b>Heat Loss Data</b> . . . . .	<b>136</b>
<b>A.4</b>	<b>Derating Data</b> . . . . .	<b>137</b>
	Temperature Derating . . . . .	137
	Altitude Derating . . . . .	137
<b>B.</b>	<b>PARAMETER LIST</b> . . . . .	<b>139</b>
<b>B.1</b>	<b>Parameter Groups</b> . . . . .	<b>140</b>
<b>B.2</b>	<b>Parameter Tables</b> . . . . .	<b>141</b>
	A: Initialization Parameters . . . . .	141
	b: Application . . . . .	142
	C: Tuning . . . . .	142
	F: Options . . . . .	143
	H: Multi-Function Terminals . . . . .	145

L: Protection Function	150
o: Operator-Related Settings	151
U: Monitors	153
<b>B.3 Defaults by Unit Model</b>	<b>158</b>
<b>C. MEMOBUS/MODBUS COMMUNICATIONS</b>	<b>159</b>
<b>C.1 MEMOBUS/Modbus Configuration</b>	<b>160</b>
<b>C.2 Communication Specifications</b>	<b>161</b>
<b>C.3 Connecting to a Network</b>	<b>162</b>
Network Cable Connection	162
Network Termination	162
<b>C.4 MEMOBUS/Modbus Setup Parameters</b>	<b>163</b>
MEMOBUS/Modbus Serial Communication	163
<b>C.5 Regenerative Unit Operations by MEMOBUS/Modbus</b>	<b>165</b>
Observing the Regenerative Unit Operation	165
Controlling the Regenerative Unit	165
<b>C.6 Communications Timing</b>	<b>166</b>
Command Messages from Master to Regenerative Unit	166
Response Messages from Regenerative Unit to Master	166
<b>C.7 Message Format</b>	<b>167</b>
Message Content	167
Slave Address	167
Function Code	167
Data	167
Error Check	168
<b>C.8 Message Examples</b>	<b>169</b>
Reading Regenerative Unit MEMOBUS/Modbus Register Contents	169
Loopback Test	169
Writing to Multiple Registers	170
<b>C.9 MEMOBUS/Modbus Data Table</b>	<b>171</b>
Command Data	171
Monitor Data	172
Fault Trace Contents	179
Alarm Register Contents	180
<b>C.10 Enter Command</b>	<b>181</b>
Enter Command Types	181
<b>C.11 Communication Errors</b>	<b>182</b>
MEMOBUS/Modbus Error Codes	182
Slave Not Responding	182
<b>C.12 Self-Diagnostics</b>	<b>183</b>
<b>D. STANDARDS COMPLIANCE</b>	<b>185</b>
<b>D.1 Section Safety</b>	<b>186</b>
<b>D.2 European Standards</b>	<b>188</b>
CE Low Voltage Directive Compliance	188
EMC Guidelines Compliance	190
<b>D.3 UL Standards</b>	<b>191</b>
UL Standards	191
UL Standards Compliance	191
Power Coordinating Reactor/Current Suppression Reactor	200
Installing Standard Configuration Devices	200
Precautionary Notes on External Heatsink (IP00/Open Type enclosure)	201
<b>Revision History</b>	<b>202</b>

# Preface & General Safety

---

This section provides safety messages pertinent to this product that, if not heeded, may result in fatality, personal injury, or equipment damage. Yaskawa is not responsible for the consequences of ignoring these instructions.

<b>i.1</b>	<b>PREFACE</b> .....	<b>8</b>
<b>i.2</b>	<b>GENERAL SAFETY</b> .....	<b>9</b>

## i.1 Preface

Yaskawa manufactures products used as components in a wide variety of industrial systems and equipment. The selection and application of Yaskawa products remain the responsibility of the equipment manufacturer or end user. Yaskawa accepts no responsibility for the way its products are incorporated into the final system design. Under no circumstances should any Yaskawa product be incorporated into any product or design as the exclusive or sole safety control. Without exception, all controls should be designed to detect faults dynamically and fail safely under all circumstances. All systems or equipment designed to incorporate a product manufactured by Yaskawa must be supplied to the end user with appropriate warnings and instructions as to the safe use and operation of that part. Any warnings provided by Yaskawa must be promptly provided to the end user. Yaskawa offers an express warranty only as to the quality of its products in conforming to standards and specifications published in the Yaskawa manual. **NO OTHER WARRANTY, EXPRESS OR IMPLIED, IS OFFERED.** Yaskawa assumes no liability for any personal injury, property damage, losses, or claims arising from misapplication of its products.

This manual is designed to ensure correct and suitable application of R1000-Series Regenerative Units. Read this manual before attempting to install, operate, maintain, or inspect a regenerative unit and keep it in a safe, convenient location for future reference. Be sure you understand all precautions and safety information before attempting application.

### ◆ Applicable Documentation

The following manuals are available for R1000 series:

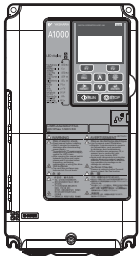
	YASKAWA R1000 Series Power Regenerative Unit Quick Start Guide (TOEP C710656 09)
	This guide is packaged together with the product and contains basic information required to install and wire the regenerative unit, in addition to an overview of fault diagnostics, maintenance, and parameter settings. It is meant to get the regenerative unit ready for a trial run with the application and for basic operation.
	YASKAWA R1000 Series Power Regenerative Unit Quick Start Guide (SIEP C710656 09) (This document)
	This manual is available for download on our documentation website, <a href="http://www.yaskawa.eu.com">www.yaskawa.eu.com</a> . It provides detailed information on parameter settings, functions, and MEMOBUS/Modbus specifications. Use this manual to expand the functionality of the regenerative unit and to take advantage of higher performance features.

### ◆ Symbols

**Note:** Indicates a supplement or precaution that does not cause regenerative unit damage.

### ◆ Terms and Abbreviations

- **Regenerative Unit:** YASKAWA R1000 Series Power Regenerative Unit
- **Drive:** Yaskawa 1000-Series Drive
- **BCD:** Binary Coded Decimal
- **H:** Hexadecimal Number Format
- **IGBT:** Insulated Gate Bipolar Transistor

### ◆ Trademarks

- MECHATROLINK-I/MECHATROLINK-II are trademarks of MECHATROLINK Members Association (MMA).
- Other companies and product names mentioned in this manual are trademarks of those companies.

## i.2 General Safety

### ◆ Supplemental Safety Information

#### General Precautions

- The diagrams in this manual may be indicated without covers or safety shields to show details. Replace the covers or shields before operating the regenerative unit and run the regenerative unit according to the instructions described in this manual.
- Any illustrations, photographs, or examples used in this manual are provided as examples only and may not apply to all products to which this manual is applicable.
- The products and specifications described in this manual or the content and presentation of the manual may be changed without notice to improve the product and/or the manual.
- When ordering a new copy of the manual due to damage or loss, contact your Yaskawa representative or the nearest Yaskawa sales office and provide the manual number shown on the front cover.
- If nameplate becomes worn or damaged, order a replacement from your Yaskawa representative or the nearest Yaskawa sales office.

#### WARNING

Read and understand this manual before installing, operating or servicing the regenerative unit. The regenerative unit must be installed according to this manual and local codes.

The following conventions are used to indicate safety messages in this manual. Failure to heed these messages could result in serious or fatal injury or damage to the products or to related equipment and systems.

#### DANGER

Indicates a hazardous situation, which, if not avoided, will result in death or serious injury.

#### WARNING

Indicates a hazardous situation, which, if not avoided, could result in death or serious injury.

**WARNING!** may also be indicated by a bold key word embedded in the text followed by an italicized safety message.

#### CAUTION

Indicates a hazardous situation, which, if not avoided, could result in minor or moderate injury.

**CAUTION!** may also be indicated by a bold key word embedded in the text followed by an italicized safety message.

#### NOTICE

Indicates a property damage message.

**NOTICE:** may also be indicated by a bold key word embedded in the text followed by an italicized safety message.

### ◆ Safety Messages

#### DANGER

##### **Heed the safety messages in this manual.**

Failure to comply will result in death or serious injury.

The operating company is responsible for any injuries or equipment damage resulting from failure to heed the warnings in this manual.

##### **Electrical Shock Hazard**

##### **Do not install, wire, maintain, or inspect the product or replace parts while the power supply is turned on.**

Failure to comply will result in death or serious injury.

Disconnect all power to the equipment. The internal capacitor remains charged even after the power supply is turned off. After shutting off the power, wait for at least the amount of time specified on the regenerative unit before touching any components.

#### WARNING

##### **Sudden Movement Hazard**

##### **System may start unexpectedly upon application of power, resulting in death or serious injury.**

Clear all personnel from the regenerative unit, drive, motor and machine area before applying power to the regenerative unit. Secure covers, couplings, shaft keys and machine loads.

##### **Electrical Shock Hazard**

##### **Do not attempt to modify or alter the regenerative unit in any way not explained in this manual.**

Failure to comply could result in death or serious injury.

Yaskawa is not responsible for any modification of the product made by the user. This product must not be modified.

##### **Do not allow unqualified personnel to perform work on the regenerative unit.**

Failure to comply could result in death or serious injury.

Installation, maintenance, inspection, and servicing must be performed only by authorized personnel familiar with installation, adjustment, and maintenance of regenerative units.

##### **Do not remove covers or touch circuit boards while the power is on.**

Failure to comply could result in death or serious injury.

##### **Always use a ground wire that complies with technical standards on electrical equipment and minimize the length of the ground wire.**

Improper equipment grounding may cause dangerous electrical potentials on equipment chassis, which could result in death or serious injury.

##### **Always use a type B residual current monitoring/detection (RCM or RCD) according to IEC/EN 60755 when a protective residual current monitor/detection device is installed for indirect or direct shock hazard protection.**

The regenerative unit can cause a residual current with a DC component in the protective earthing conductor.

##### **Do not operate equipment with covers removed.**

Failure to comply could result in death or serious injury.

**⚠ WARNING****Fire Hazard****Do not use an improper voltage source.**

Failure to comply could result in death or serious injury by fire.

Verify that the rated voltage of the regenerative unit matches the voltage of the incoming power supply before applying power.

**Tighten all terminal screws to the specified tightening torque.**

Loose electrical connections could result in death or serious injury by fire due to overheating of electrical connections.

**Do not use improper combustible materials.**

Failure to comply could result in death or serious injury by fire.

Do not install the regenerative unit to a combustible surface. Never place combustible materials on the regenerative unit.

**Crush Hazard****Only allow qualified personnel to operate a crane or hoist to transport the regenerative unit.**

Failure to comply may result in serious injury or death from falling equipment.

**⚠ CAUTION****Do not carry the regenerative unit by the front cover or the terminal cover.**

Failure to comply may result in minor or moderate injury from the main body of the regenerative unit falling.

**NOTICE****Do not disconnect the wiring to the regenerative unit while the regenerative unit is outputting a voltage.**

Improper equipment sequencing could result in damage to the regenerative unit.

**Connect a power supply with a capacity (kVA) that is larger than the rated input capacity (kW) of the regenerative unit.**

Failure to comply could result in damage to the regenerative unit.

**Observe proper electrostatic discharge procedures (ESD) when handling the regenerative unit, circuit boards, and CMOSIC.**

Failure to comply may result in ESD damage to the regenerative unit circuitry.

**Do not perform a withstand voltage test on any part of the regenerative unit.**

Failure to comply could result in damage to the sensitive devices within the regenerative unit.

**Do not operate damaged equipment.**

Failure to comply could result in further damage to the equipment.

Do not connect or operate any equipment with visible damage or missing parts.

**Install adequate branch circuit short circuit protection per applicable codes.**

Failure to comply could result in damage to the regenerative unit.

The regenerative unit is suitable for circuits capable of delivering not more than 100,000 RMS symmetrical Amperes, 240 Vac maximum (200 V Class) and 480 Vac maximum (400 V Class).

**Prevent foreign matter such as metal shavings or wire clippings from falling into the regenerative unit during regenerative unit installation and project construction.**

Failure to comply could result in damage to the regenerative unit. Place a temporary cover over the top during installation. Be sure to remove the temporary cover before start-up, as the cover will reduce ventilation and cause the regenerative unit to overheat.

**NOTICE**

**Never lift the regenerative unit up while the cover is removed.**

This can damage the terminal board and other components.

**Do not perform signal checks during operation.**

Failure to comply could result in damage to the regenerative unit.

**Do not modify the circuitry of the regenerative unit.**

Failure to comply could result in damage to the regenerative unit and will void warranty.

Yaskawa is not responsible for any modification of the product made by the user. This product must not be modified.

**Do not expose the regenerative unit to halogen group disinfectants.**

Failure to comply may cause damage to the electrical components in the regenerative unit.

Do not pack the regenerative unit in wooden materials that have been fumigated or sterilized.

Do not sterilize the entire package after the product is packed.

### ◆ General Application Precautions

#### ■ Load Capacity

- Install the regenerative unit in one-to-one with a drive. Do not connect the multiple drives to a regenerative unit.
- Connect R1000 to a drive with same maximum applicable motor capacity (Heavy Duty rating [HD]).
- Do not connect regenerative units in parallel.

#### ■ Selecting the Capacity

Refer to [Table i.1](#) to select the regenerative unit capacity.

Depending on the amount of regenerated energy, you can select an R1000 with a smaller capacity than the drive.

Use the DriveSelect Inverter Capacity Selection Program to make the selection.

Contact your Yaskawa representative or the nearest Yaskawa sales office.

**Table i.1 Model Selection**

Drive Capacity or Motor Capacity (kW)	Model	
	200 V Class	400 V Class
≤ 4.0	2A03P5	4A03P5
5.5	2A0005	4A0005
7.5	2A0007	4A0007
11	2A0010	4A0010
15	2A0014	4A0014
18.5	2A0017	4A0017
22	2A0020	4A0020
30	2A0028	4A0028
37	2A0035	4A0035
45	2A0053	4A0043
55		4A0053
75	2A0073	4A0073
90	2A0105	4A0105
110		
132	–	4A0150
160	–	
185	–	4A0210
220	–	
315	–	4A0300



## ■ Installing Standard Configuration Devices

Each regenerative unit requires a corresponding set of input fuses, power coordinating reactor, and current suppression reactor. Always install the specified devices.

### ■ Installation

#### Enclosure Panels

Keep the regenerative unit in a clean environment by installing the regenerative unit in an enclosure panel or selecting an installation area free of airborne dust, lint, and oil mist. Be sure to leave the required space between regenerative units to provide for cooling, and take proper measures so the ambient temperature remains within allowable limits and keep flammable materials away from the regenerative unit. Yaskawa offers protective designs for regenerative units that must be used in areas subjected to oil mist and excessive vibration. Contact Yaskawa or your Yaskawa agent for details.

#### Installation Direction

**NOTICE:** Install the regenerative unit upright as specified in the manual. Refer to [Mechanical Installation on page 19](#) for more information on installation. Failure to comply may damage the regenerative unit due to improper cooling

### ■ General Handling

#### Wiring Check

**NOTICE:** Do not connect power supply lines to output terminals. Failure to comply will destroy the regenerative unit. Be sure to perform a final check of all sequence wiring and other connections before turning on the power and also check for short circuits on the control terminals, which may damage the regenerative unit.

#### Inspection and Maintenance

**WARNING!** Electrical Shock Hazard. Capacitors in the regenerative unit do not immediately discharge after shutting off the power. Wait for at least the amount of time specified on the regenerative unit before touching any components after shutting off the power. Failure to comply may cause injury to personnel from electrical shock.

**WARNING!** Burn Hazard. Because the heatsink can get very hot during operation, take proper precautions to prevent burns. When replacing the cooling fan, shut off the power and wait at least 15 minutes to be sure that the heatsink has cooled down. Failure to comply may cause burn injury to personnel.

To connect or perform maintenance for the standard configuration devices, turn off the power supply to the regenerative unit, wait for the time that is given on the regenerative unit, and then confirm that the temperature of the reactor has sufficiently decreased before you proceed.

#### Wiring

Yaskawa recommends using ring terminals on all models. Regenerative units require the use of ring terminals for UL/cUL compliance. Use only the tools recommended by the terminal manufacturer for crimping.

#### Transporting and Installing the Regenerative Unit

**NOTICE:** Never steam clean the regenerative unit. During transport, keep the regenerative unit from coming into contact with salts, fluorine, bromine, phthalate ester, and other such harmful chemicals.

**CAUTION!** Crush Hazard. Carry all standard configuration and peripheral devices in a method suitable for the weight of the device. Incorrectly handling devices could cause them to fall and result in injury or damage to the device.

Always use a three-phase power supply. The regenerative unit cannot be used with a single-phase power supply.

## ◆ Precautions on Using Peripheral Devices

### ■ Installing a Noise Filter

Install a reactor-type noise filter without a capacitor such as a zero phase reactor after the MCCB on the power supply side when installing a noise filter on the power supply.

**NOTICE:** Do not install a filter with a built-in capacitor. The harmonic components may cause the capacitor to overheat or may damage the capacitor. Always install the specified harmonic noise filter.

#### Wire Gauges and Wiring Distances

Use a motor cable gauge large enough to avoid unstable regenerative unit phase control from voltage drop caused by a long motor cable.

## i.2 General Safety

When using the digital operator remotely, always use the cable specified (option). When controlling the regenerative unit remotely using analog signals, limit the length of the control lines between the control signals and regenerative unit to 50 m or shorter and separate the control lines from power lines (main circuit and sequence circuits) to prevent induction from peripheral devices.

When using a multi-function analog input, connect the shield wire to the sheath ground terminal E (G) with shielded twisted-pair wires. Refer to *Standard Connection Diagram on page 32* for details.

### ◆ Warning Label Example

Always heed the warning information in the position shown in *Figure i.1*.

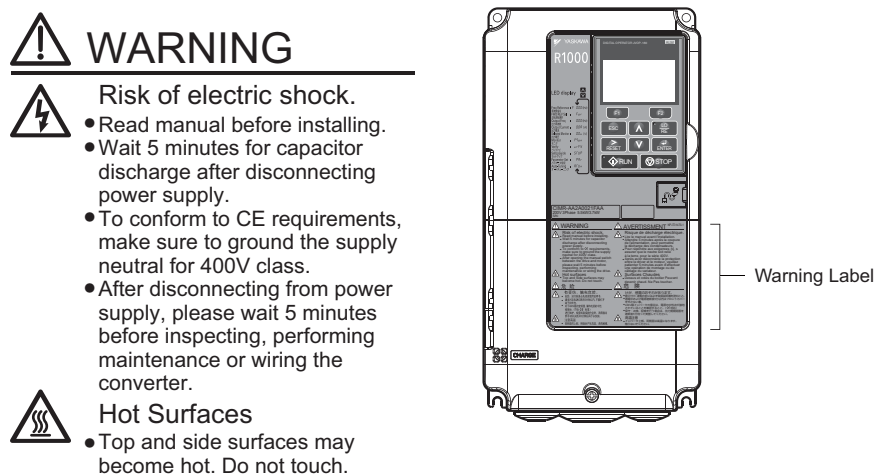

Figure i.1 Warning Information Position

### ◆ Warranty Information

#### ■ Restrictions

The regenerative unit is not designed or manufactured for use in devices or systems that may directly affect or threaten human lives or health.

Customers who intend to use the product described in this manual for devices or systems relating to transportation, health care, space aviation, atomic power, electric power, or in underwater applications must first contact their Yaskawa representatives or the nearest Yaskawa sales office.

**WARNING! Injury to Personnel.** This product has been manufactured under strict quality-control guidelines. However, if this product is to be installed in any location where failure of this product could involve or result in a life-and-death situation or loss of human life or in a facility where failure may cause a serious accident or physical injury, safety devices must be installed to minimize the likelihood of any accident.

## Receiving

---

This chapter explains how to inspect the regenerative unit upon receipt, and gives an overview of the different enclosure types and components.

<b>1.1</b>	<b>SECTION SAFETY</b> .....	<b>16</b>
<b>1.2</b>	<b>MODEL NUMBERS AND NAMEPLATES</b> .....	<b>17</b>
<b>1.3</b>	<b>REGENERATIVE UNIT MODELS AND ENCLOSURE TYPES</b> .....	<b>18</b>

## 1.1 Section Safety

### CAUTION

**Do not carry the unit by the front cover or the terminal cover.**

Failure to comply may cause the main body of the regenerative unit to fall, resulting in minor or moderate injury.

### NOTICE

**Observe proper electrostatic discharge procedures (ESD) when handling the regenerative unit and circuit boards.**

Failure to comply may result in ESD damage to circuitry.

# 1.2 Model Numbers and Nameplates

Perform the following tasks after receiving the regenerative unit:

- Inspect the regenerative unit for damage. If the regenerative unit appear damaged upon receipt, contact the shipper immediately.
- Verify receipt of the correct model by checking the information on the nameplate.
- If you have received the wrong model or the regenerative unit does not function properly, contact your supplier.

## ◆ Nameplate

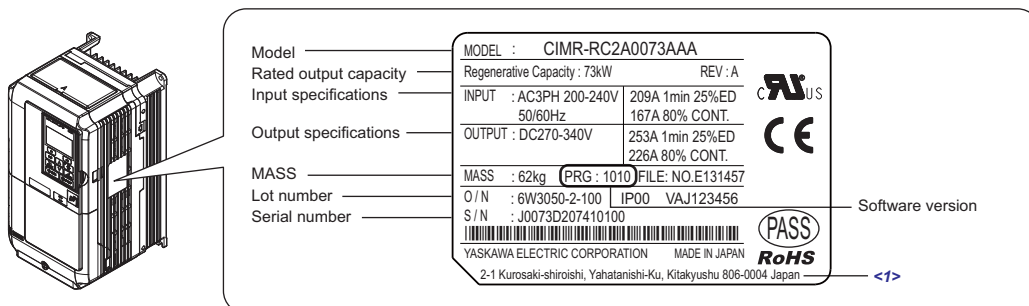

<1> The address of the head office of Yaskawa Electric Corporation (responsible for product liability) is shown on the nameplate.

Figure 1.1 Regenerative Unit Nameplate Information Example

## ◆ Model Numbers

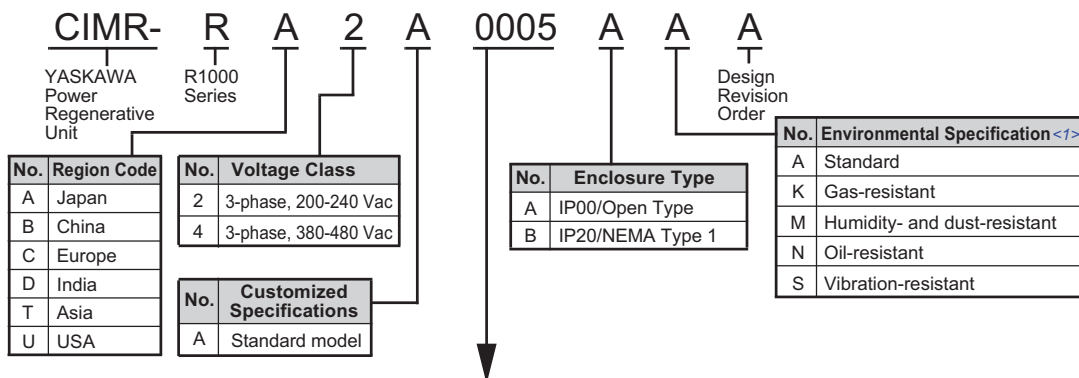

Three-Phase 200 V	
Model	Rated Output Capacity (kW)
03P5	4
0005	5
0007	7
0010	10
0014	14
0017	17
0020	20
0028	28
0035	35
0053	53
0073	73
0105	105

Three-Phase 400 V	
Model	Rated Output Capacity (kW)
03P5	4
0005	5
0007	7
0010	10
0014	14
0017	17
0020	20
0028	28
0035	35
0043	43
0053	53
0073	73
0105	105
0150	150
0210	210
0300	300

<1> Regenerative units with these specifications do not guarantee complete protection for the environmental conditions indicated.

## 1.3 Regenerative Unit Models and Enclosure Types

Two types of enclosures are offered for R1000 regenerative units:

- IP00/Open Type enclosure models are designed for installation in an enclosure panel that serves to protect personnel from injury caused by accidentally touching live parts.
- IP20/NEMA Type 1 enclosure models mount to an indoor wall or in an enclosure panel. Removing the top protective cover from a IP20/NEMA Type 1 enclosure drive voids NEMA Type 1 protection while retaining IP20 conformity.

*Table 1.1* describes regenerative unit enclosures and models.

**Table 1.1 Models and Enclosure Types**

Voltage Class	Enclosure Type	
	IP20/NEMA Type 1	IP00/Open Type
Three-Phase 200 V Class	2A03P5	2A0035
	2A0005	2A0053
	2A0007	2A0073
	2A0010	2A0105
	2A0014	–
	2A0017	–
	2A0020	–
	2A0028	–
Three-Phase 400 V Class	4A03P5	4A0035
	4A0005	4A0043
	4A0007	4A0053
	4A0010	4A0073
	4A0014	4A0105
	4A0017	4A0150
	4A0020	4A0210
	4A0028	4A0300

## Mechanical Installation

---

This chapter explains how to properly mount and install the regenerative unit.

<b>2.1</b>	<b>SECTION SAFETY</b> .....	<b>20</b>
<b>2.2</b>	<b>MECHANICAL INSTALLATION</b> .....	<b>21</b>

## 2.1 Section Safety

### WARNING

#### Fire Hazard

**Ensure proper cooling when installing an IP00/IP20 regenerative unit in a closed panel or cabinet.**

Ensure the air temperature entering the regenerative unit is 50 °C or cooler by use of a cooling fan or air conditioner. Failure to comply could result in overheating and fire.

#### Crush Hazard

**Only allow qualified personnel to operate a crane or hoist to transport the unit.**

Failure to comply may result in serious injury or death from falling equipment.

**Use a dedicated lifter when transporting the unit by a lifter.**

Failure to comply may result in serious injury or death from falling equipment.

**Only use vertical suspension to temporarily lift the unit during installation to an enclosure panel.**

Do not use vertical suspension to transport the unit.

Failure to comply may result in serious injury or death from falling equipment.

**Use screws to securely affix the unit front cover, terminal blocks, and other unit components prior to vertical suspension.**

Failure to comply may result in serious injury or death from falling equipment.

**Do not subject the unit to vibration or impact greater than 1.96 m/s<sup>2</sup> (0.2 G) while it is suspended by the cables.**

Failure to comply may result in serious injury or death from falling equipment.

**Do not attempt to flip the unit over or leave the unit unattended while it is suspended by the wires.**

Failure to comply may result in serious injury or death from falling equipment.

### CAUTION

#### Crush Hazard

**Do not carry the unit by the front cover or the terminal cover.**

Failure to comply may result in minor or moderate injury from the main body of the unit falling.



## 2.2 Mechanical Installation

This section outlines specifications, procedures, and the environment for proper mechanical installation of the regenerative unit.

### ◆ Installation Environment

Install the regenerative unit in an environment matching the specifications in [Table 2.1](#) to help prolong the optimum performance life of the regenerative unit.

**Table 2.1 Installation Environment**

Environment	Conditions
<b>Installation Area</b>	Indoors
<b>Ambient Temperature</b>	IP00/Open Type enclosure: -10 °C to +50 °C IP20/NEMA Type 1 enclosure: -10 °C to +40 °C Regenerative unit reliability improves in environments without wide temperature fluctuations. When using the regenerative unit in an enclosure panel, install a cooling fan or air conditioner in the area to ensure that the air temperature inside the enclosure does not exceed the specified levels. Do not allow ice to develop on the regenerative unit.
<b>Humidity</b>	95% RH or less and free of condensation
<b>Storage Temperature</b>	-20 °C to +60 °C
<b>Surrounding Area</b>	Install the regenerative unit in an area free from: <ul style="list-style-type: none"> <li>• oil mist and dust</li> <li>• metal shavings, oil, water, or other foreign materials</li> <li>• radioactive materials</li> <li>• combustible materials (e.g., wood)</li> <li>• harmful gases and liquids</li> <li>• excessive vibration</li> <li>• chlorides</li> <li>• direct sunlight.</li> </ul>
<b>Altitude</b>	1000 m or lower, up to 3000 m with derating. Refer to <a href="#">Derating Data on page 137</a> for details.
<b>Vibration</b>	10 to 20 Hz at 9.8 m/s <sup>2</sup> , 20 to 55 Hz at 5.9 m/s <sup>2</sup> (2A03P5 to 2A0053, 4A03P5 to 4A0073) 10 to 20 Hz at 9.8 m/s <sup>2</sup> , 20 to 55 Hz at 2.0 m/s <sup>2</sup> (2A0073 to 2A0105, 4A0105 to 4A0300)
<b>Orientation</b>	Install the regenerative unit vertically to maintain maximum cooling effects.

**WARNING! Fire Hazard.** When installing an IP00/IP20 regenerative unit in a closed panel or cabinet, sufficiently cool the panel or cabinet with a cooling fan or air conditioner so that the air temperature entering the regenerative unit is 50 °C or cooler. Failure to comply could result in overheating and fire.

**NOTICE:** Avoid placing regenerative unit peripheral devices, transformers, or other electronics near the regenerative unit as the noise created can lead to erroneous operation. If such devices must be used in close proximity to the regenerative unit, take proper steps to shield the regenerative unit from noise.

**NOTICE:** Prevent foreign matter such as metal shavings and wire clippings from falling into the regenerative unit during installation. Failure to comply could result in damage to the regenerative unit. Place a temporary cover over the top of the regenerative unit during installation. Remove the temporary cover before regenerative unit start-up, as the cover will reduce ventilation and cause the regenerative unit to overheat.

### ◆ Installation Orientation and Spacing

Install the regenerative unit upright as illustrated in [Figure 2.1](#) to maintain proper cooling.

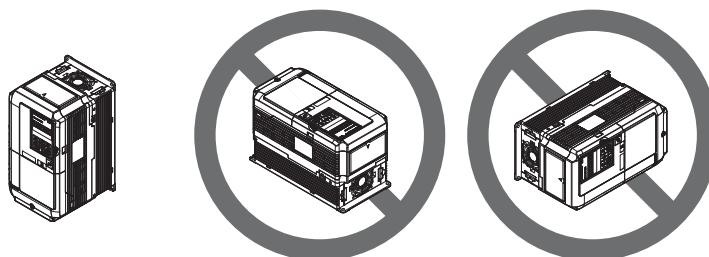
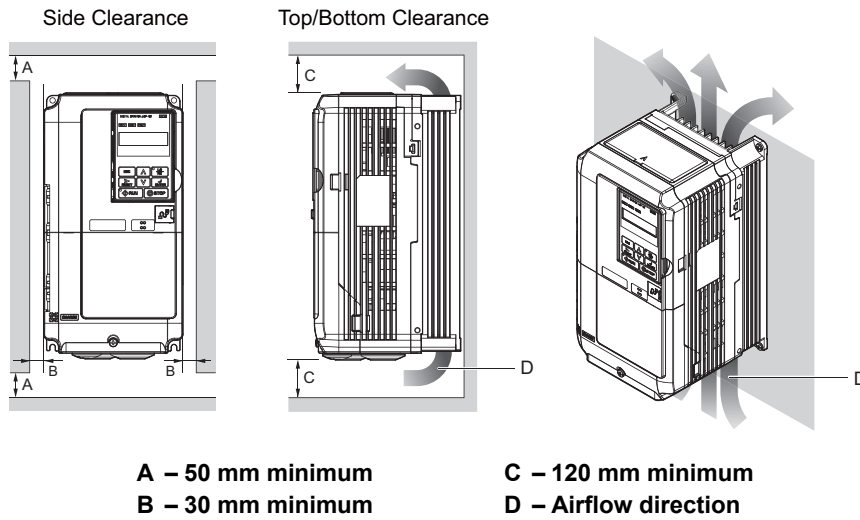

**Figure 2.1 Correct Installation Orientation**

## 2.2 Mechanical Installation

### ■ Single Regenerative Unit Installation

*Figure 2.2* shows the installation distance required to maintain sufficient space for airflow and wiring. Install the heatsink against a closed surface to avoid diverting cooling air around the heatsink.



**Figure 2.2** Correct Installation Spacing (Single)

### ■ Parallel Mounting with Drive

When installing the regenerative unit beside a drive, mount the devices according to *Figure 2.3*.

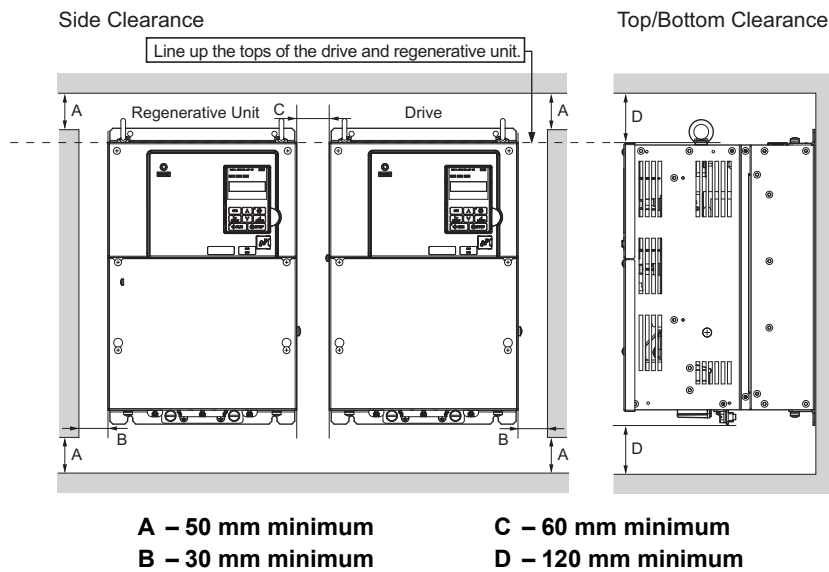

**Figure 2.3** Space Between Regenerative Unit and Drive (Parallel Mounting)

### ■ Side-by-Side Installation with Drive

Models 2A03P5 to 2A0028, 4A03P5 to 4A0028 can take advantage of Side-by-Side installation.

When installing the regenerative unit beside a drive, mount the devices according to [Figure 2.4](#) and set L8-35, Installation Method Selection, to 1 (Side-by-Side Mounting).

When mounting regenerative units with the minimum clearance of 2 mm according to [Figure 2.5](#), set parameter L8-35 to 1 while considering derating. Refer to [Parameter Tables on page 141](#) for details.

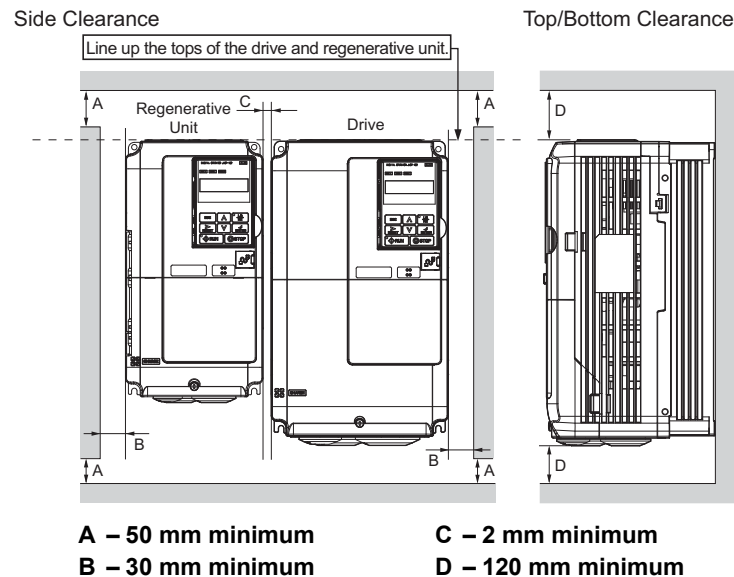

**Figure 2.4 Space Between Regenerative Unit and Drive (Side-by-Side)**

**Note:** Align the tops of the regenerative unit and the drives when installing the regenerative unit and the drives of different heights in the same enclosure panel. Leave space between the tops and bottoms of stacked regenerative unit and drives for easier cooling fan replacement.

### ■ Installation Screws

Refer to [Exterior and Mounting Dimensions on page 26](#) for the sizes of the installation screws.

### ◆ Precautions and Instructions for Installation

Read the following precautions and instructions before installing models 2A0073, 2A0105, and 4A0210 to 4A0300.

**WARNING!** *Crush Hazard. Observe the following instructions and precautions. Failure to comply could result in serious injury or death from falling equipment.*

- Only use vertical suspension to temporarily lift the regenerative unit during installation to an enclosure panel.
- Do not use vertical suspension to transport the regenerative unit.
- Use screws to securely affix the regenerative unit front cover, terminal blocks, and other regenerative unit components prior to vertical suspension.
- Do not subject the regenerative unit to vibration or impact greater than  $1.96 \text{ m/s}^2$  (0.2 G) while it is suspended by the wires.
- Do not attempt to flip the regenerative unit over while it is suspended by the wires.
- Do not leave the regenerative unit unattended while it is suspended by the wires.

## 2.2 Mechanical Installation

### ■ Horizontal Suspension of Models 2A0073, 2A0105, and 4A0105 to 4A0300

To make a wire hanger or frame for use when lifting the regenerative unit with a crane, lay the regenerative unit in a horizontal position and pass a wire through the holes of the four eye bolts.

**NOTICE:** *Damage to Equipment.* When lifting the regenerative unit, confirm that the spring washer is fully closed. Failure to comply may deform or damage the regenerative unit when lifted.

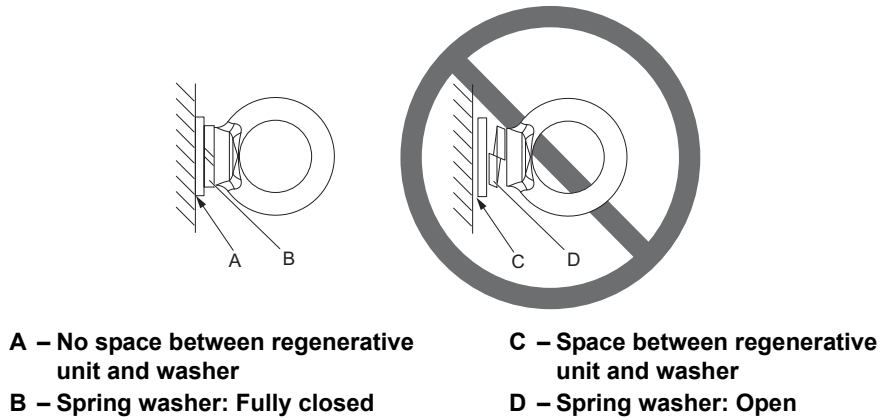

Figure 2.5 Details of Spring Washers

### ■ Vertical Suspension of Models 2A0073, 2A0105, and 4A0105 to 4A0300

When vertical suspension of the regenerative unit is required in an enclosure panel, the orientation of the eye bolts for these regenerative unit models can be easily changed by turning the eye bolts counterclockwise 90 degrees.

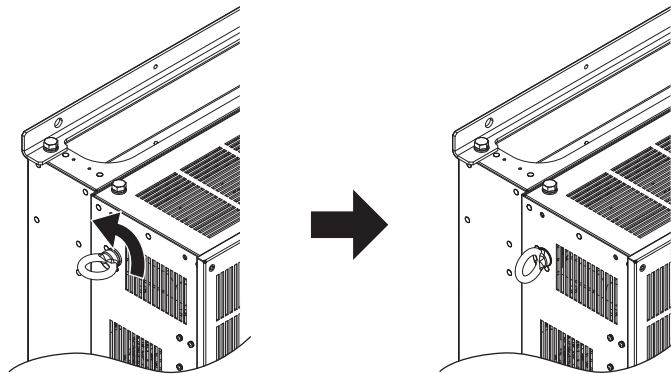

Figure 2.6 Adjusting Angle of Eye Bolts

1. Gradually take up the slack in the wires and hoist the regenerative unit after the wires are stretched tight.
2. Lower the regenerative unit when ready to install in the enclosure panel. Stop lowering the regenerative unit when it is near the floor then begin lowering the regenerative unit again very slowly until the regenerative unit is placed correctly.

◆ Digital Operator Remote Usage

■ Remote Operation

The digital operator mounted on the regenerative unit can be removed and connected to the regenerative unit using an extension cable up to 3 m long to facilitate operation when the regenerative unit is installed in a location where it can not be easily accessed.

The digital operator can also be permanently mounted in remote locations such as panel doors using an extension cable and an installation support set (depending on the installation type).

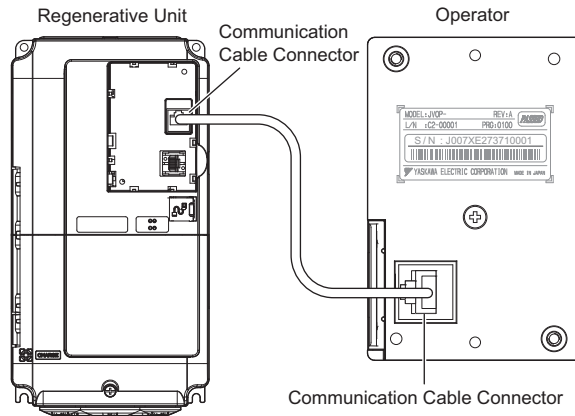

■ Digital Operator Dimensions

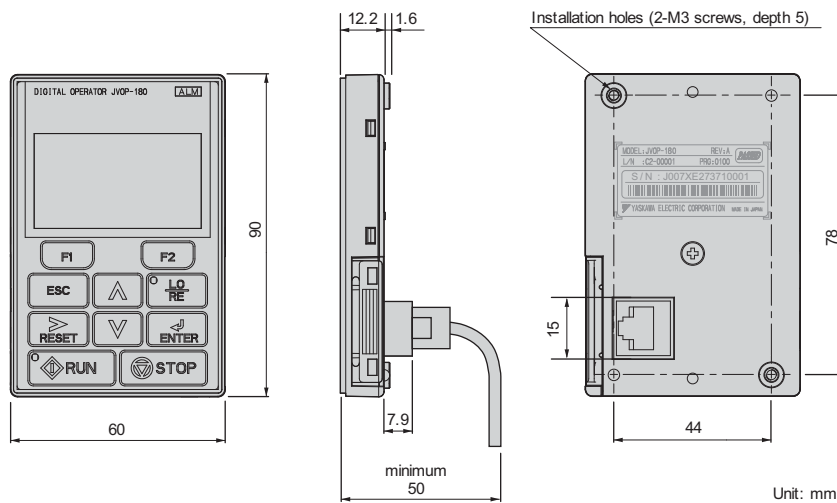

<1> If you install the digital operator in a control panel or other enclosure, use the optional connection cable.

Figure 2.7 Digital Operator Dimensions

## 2.2 Mechanical Installation

### ■ Installation Types and Required Materials

The digital operator mounts to an enclosure two different ways:

- External/face-mount installs the operator outside the enclosure panel
- Internal/flush-mount installs the operator inside the enclosure panel

**Table 2.2 Digital Operator Installation Methods and Required Tools**

Installation Method	Description	Installation Support Sets	Model	Required Tools
External/ Face-Mount	Simplified installation with the digital operator is mounted on the outside of the panel with two screws.	–	–	Phillips screwdriver (#1)
Internal/ Flush-Mount	Encloses the digital operator in the panel. The front of the digital operator is flush with the outside of the panel.	Installation Support Set A (for mounting with screws through holes in the panel)	EZZ020642A	Phillips screwdriver (#1, #2)
		Installation Support Set B (for use with threaded studs that are fixed to the panel) <1>	EZZ020642B	Phillips screwdriver (#1) Wrench (7 mm)

<1> If there are welding studs in the control panel, use the Installation Support Set B (for threaded studs).

**NOTICE:** Prevent foreign matter such as metal shavings or wire clippings from falling into the drive or regenerative unit during installation and project construction. Failure to comply could result in damage to the drive or regenerative unit. Place a temporary cover over the top of the drive and regenerative unit during installation. Remove the temporary cover before drive and regenerative unit start-up, as the cover will reduce ventilation and cause the drive or regenerative unit to overheat.

### ◆ Exterior and Mounting Dimensions

Use [Table 2.3](#) to find the regenerative unit dimension drawings.

**Table 2.3 Models and Types**

Protective Design	Regenerative Unit Model		Page
	Three-Phase 200 V Class	Three-Phase 400 V Class	
IP20/NEMA Type 1 Enclosure	2A03P5	4A03P5	27
	2A0005	4A0005	
	2A0007	4A0007	
	2A0010	4A0010	
	2A0014	4A0014	
	2A0017	4A0017	
	2A0020	4A0020	
	2A0028	4A0028	
IP00/Open Type Enclosure	2A0035	4A0035	28
	2A0053	4A0043	
	2A0073	4A0053	
	2A0105	4A0073	
		4A0105	
		4A0150	
		4A0210	
		4A0300	

■ IP20/NEMA Type 1 Enclosure Models

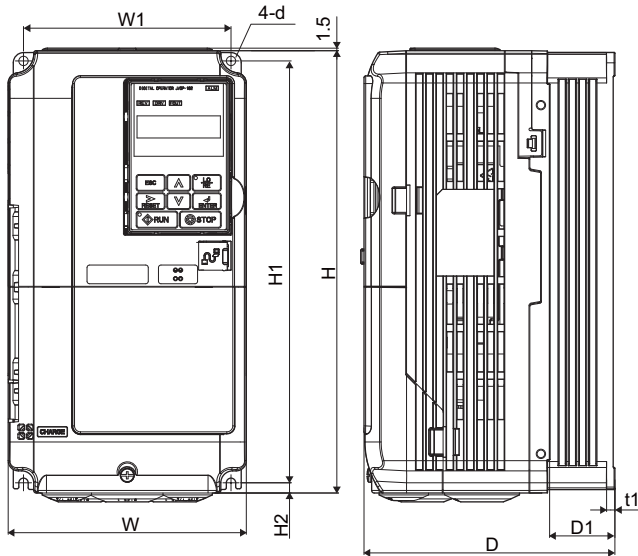

Figure 1

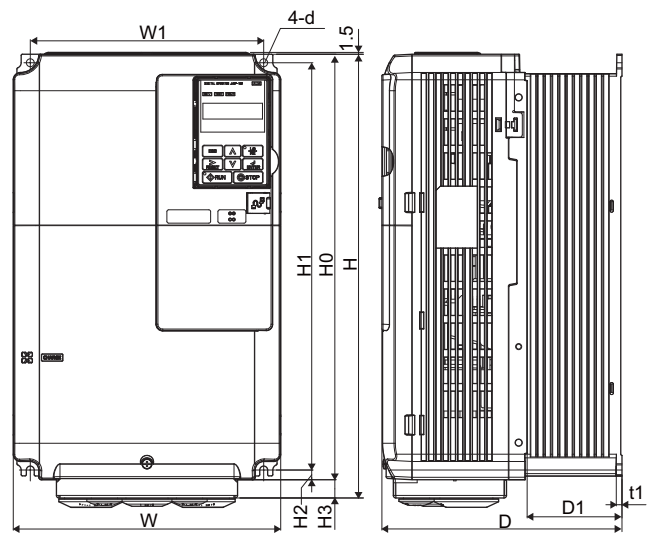

Figure 2

Table 2.4 Dimensions for IP20/NEMA Type 1 Enclosure: 200 V Class

Model	Figure	Dimensions mm											Weight kg
		W	H	D	W1	H0	H1	H2	H3	D1	t1	d	
2A03P5	1	140	260	167	122	–	248	6	–	55	5	M5	4
2A0005	1	140	260	167	122	–	248	6	–	55	5	M5	4
2A0007	1	140	260	167	122	–	248	6	–	55	5	M5	4
2A0010	1	180	300	187	160	–	284	8	–	75	5	M5	6
2A0014	1	180	300	187	160	–	284	8	–	75	5	M5	6
2A0017	2	220	365	197	192	350	335	8	15	78	5	M6	9
2A0020	2	220	365	197	192	350	335	8	15	78	5	M6	9
2A0028	2	220	385	197	192	350	335	8	35	78	5	M6	9

Table 2.5 Dimensions for IP20/NEMA Type 1 Enclosure: 400 V Class

Model	Figure	Dimensions mm											Weight kg
		W	H	D	W1	H0	H1	H2	H3	D1	t1	d	
4A03P5	1	140	260	167	122	–	248	6	–	55	5	M5	4
4A0005	1	140	260	167	122	–	248	6	–	55	5	M5	4
4A0007	1	140	260	167	122	–	248	6	–	55	5	M5	4
4A0010	1	180	300	187	160	–	284	8	–	75	5	M5	5
4A0014	1	180	300	187	160	–	284	8	–	75	5	M5	5
4A0017	2	220	365	197	192	350	335	8	15	78	5	M6	8
4A0020	2	220	365	197	192	350	335	8	15	78	5	M6	8
4A0028	2	220	365	197	192	350	335	8	15	78	5	M6	8

## 2.2 Mechanical Installation

### ■ IP00/Open Type Enclosure Models

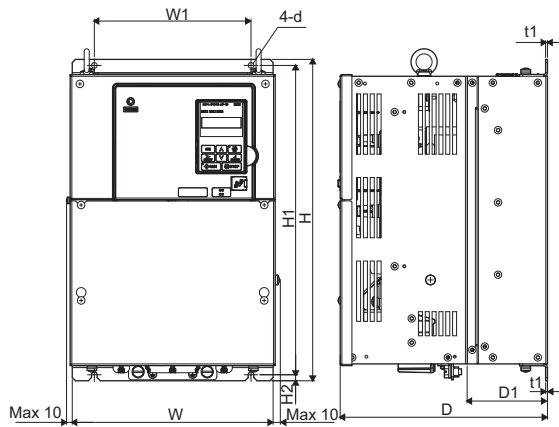

Figure 1

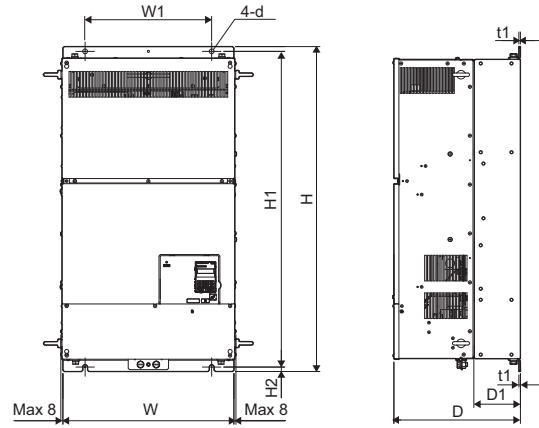

Figure 2

**Table 2.6 Dimensions for IP00/Open Type Enclosure: 200 V Class**

Model	Figure	Dimensions mm									Weight kg
		W	H	D	W1	H1	H2	D1	t1	d	
2A0035	1	275	450	258	220	435	7.5	100	2.3	M6	21
2A0053	1	325	550	283	260	535	7.5	110	2.3	M6	33
2A0073	2	450	705	330	325	680	12.5	130	3.2	M10	62
2A0105	2	500	800	350	370	773	13	130	4.5	M12	81

**Table 2.7 Dimensions for IP00/Open Type Enclosure: 400 V Class**

Model	Figure	Dimensions mm									Weight kg
		W	H	D	W1	H1	H2	D1	t1	d	
4A0035	1	275	450	258	220	435	7.5	100	2.3	M6	20
4A0043	1	275	450	258	220	435	7.5	100	2.3	M6	20
4A0053	1	325	550	283	260	535	7.5	110	2.3	M6	33
4A0073	1	325	550	283	260	535	7.5	110	2.3	M6	33
4A0105	2	450	705	330	325	680	12.5	130	3.2	M10	62
4A0150	2	450	705	330	325	680	12.5	130	3.2	M10	62
4A0210	2	500	800	350	370	773	13	130	4.5	M12	86
4A0300	2	500	800	350	370	773	13	130	4.5	M12	87



# Electrical Installation

---

This chapter explains proper procedures for wiring the control circuit terminals, motor, and power supply.

<b>3.1</b>	<b>SECTION SAFETY</b> .....	<b>30</b>
<b>3.2</b>	<b>STANDARD CONNECTION DIAGRAM</b> .....	<b>32</b>
<b>3.3</b>	<b>MAIN CIRCUIT CONNECTION DIAGRAM</b> .....	<b>34</b>
<b>3.4</b>	<b>TERMINAL BLOCK CONFIGURATION</b> .....	<b>35</b>
<b>3.5</b>	<b>TERMINAL COVER</b> .....	<b>38</b>
<b>3.6</b>	<b>DIGITAL OPERATOR AND FRONT COVER</b> .....	<b>40</b>
<b>3.7</b>	<b>TOP PROTECTIVE COVER</b> .....	<b>42</b>
<b>3.8</b>	<b>MAIN CIRCUIT WIRING</b> .....	<b>43</b>
<b>3.9</b>	<b>CONTROL CIRCUIT WIRING</b> .....	<b>48</b>
<b>3.10</b>	<b>CONTROL I/O CONNECTIONS</b> .....	<b>53</b>
<b>3.11</b>	<b>WIRING CHECKLIST</b> .....	<b>55</b>

## 3.1 Section Safety

### DANGER

#### Electrical Shock Hazard

**Do not connect or disconnect wiring while the power is on.**

Failure to comply will result in death or serious injury.

### WARNING

#### Electrical Shock Hazard

**Do not operate equipment with covers removed.**

Failure to comply could result in death or serious injury.

The diagrams in this section may show units without covers or safety shields to show details. Be sure to reinstall covers or shields before operating the unit and run the unit according to the instructions described in this manual.

**Always use a type B residual current monitoring/detection (RCM or RCD) according to IEC/EN 60755 when a protective residual current monitor/detection device is installed for indirect or direct shock hazard protection.**

The regenerative unit can cause a residual current with a DC component in the protective earthing conductor.

**Do not perform work on the unit while wearing loose clothing, jewelry or without eye protection.**

Failure to comply could result in death or serious injury.

Remove all metal objects such as watches and rings, secure loose clothing, and wear eye protection before beginning work on the unit.

**Do not remove covers or touch circuit boards while the power is on.**

Failure to comply could result in death or serious injury.

**Do not allow unqualified personnel to perform work on the unit.**

Failure to comply could result in death or serious injury.

Installation, maintenance, inspection, and servicing must be performed only by authorized personnel familiar with installation, adjustment, and maintenance of this equipment.

**Do not touch any terminals before the capacitors have fully discharged.**

Failure to comply could result in death or serious injury.

Before wiring terminals, disconnect all power to the equipment. The internal capacitor remains charged even after the power supply is turned off. After shutting off the power, wait for at least the amount of time specified on the unit before touching any components.

#### Fire Hazard

**Tighten all terminal screws to the specified tightening torque.**

Loose electrical connections could result in death or serious injury by fire due to overheating of electrical connections.

**Do not use improper combustible materials.**

Failure to comply could result in death or serious injury by fire.

Do not install the unit to a combustible surface. Never place combustible materials on the unit.

**Do not use an improper voltage source.**

Failure to comply could result in death or serious injury by fire.

Verify that the rated voltage of the unit matches the voltage of the incoming power supply before applying power.

**When installing options, perform all wiring exactly as specified in the wiring diagrams provided.**

Failure to do so can result in fire. Improper wiring may damage option components.

**⚠ CAUTION****Crush Hazard**

**Do not carry the unit by the front cover or the terminal cover.**

Failure to comply may result in minor or moderate injury from the main body of the unit falling.

**NOTICE**

**Observe proper electrostatic discharge procedures (ESD) when handling the unit and circuit boards.**

Failure to comply may result in ESD damage to the unit circuitry.

**Do not use unshielded cable for control wiring.**

Failure to comply may cause electrical interference resulting in poor system performance. Use shielded, twisted-pair wires and ground the shield to the shield ground terminal E (G) of the unit.

**Do not modify the unit circuitry.**

Failure to comply could result in damage to the unit and will void warranty.

Yaskawa is not responsible for any modification of the product made by the user. This product must not be modified.

**Check all the wiring to ensure that all connections are correct after installing the unit and connecting any other devices.**

Failure to comply could result in damage to the unit.

**Check all the wiring to ensure that all connections are correct after installing the regenerative unit and connecting any other devices.**

Failure to comply could result in damage to the regenerative unit.

### 3.2 Standard Connection Diagram

Connect the regenerative unit and peripheral devices as shown in *Figure 3.1*. It is possible to set and run the regenerative unit via the digital operator without connecting digital I/O wiring. This section does not discuss regenerative unit operation; Refer to *Start-Up Programming & Operation on page 57* for instructions on operating the regenerative unit. Refer to *Drive Connection Example on page 66* for connection with a drive.

**WARNING!** *Sudden Movement Hazard. Ensure start/stop and safety circuits are wired properly and in the correct state before energizing the regenerative unit. Failure to comply could result in death or serious injury from moving equipment.*

**NOTICE:** *If unsuitable wiring is performed, the regenerative unit could be damaged. Implement protection for branches and short-circuits according to all national and local standards.*

**NOTICE:** *Do not connect AC control circuit ground to regenerative unit enclosure. Improper grounding can cause control circuit malfunction.*

**NOTICE:** *The minimum load for the relay outputs M1-M2, M3-M4, M5-M6 and MA-MB-MC is 10 mA.*

**NOTICE:** *When installing a noise filter on the regenerative unit power supply, use a reactor-type noise filter (without a capacitor), such as a zero phase reactor, and install it after the MCCB on the power supply side. Do not install a filter with a built-in capacitor as the harmonic components may cause the capacitor to overheat or may damage the capacitor.*

**NOTICE:** *When installing a breaker or contactor on the regenerative unit side for an emergency shutoff, confirm that the CHARGE indicators on the drive and regenerative unit are not lit before closing the breaker or contactor on the regenerative unit output (DC) side. If the power supply is turned on while there is a voltage charge, an overcurrent will flow and the device may be damaged. Always confirm that the breaker or contactor on the regenerative unit output (DC) side is turned on before applying power to the regenerative unit.*

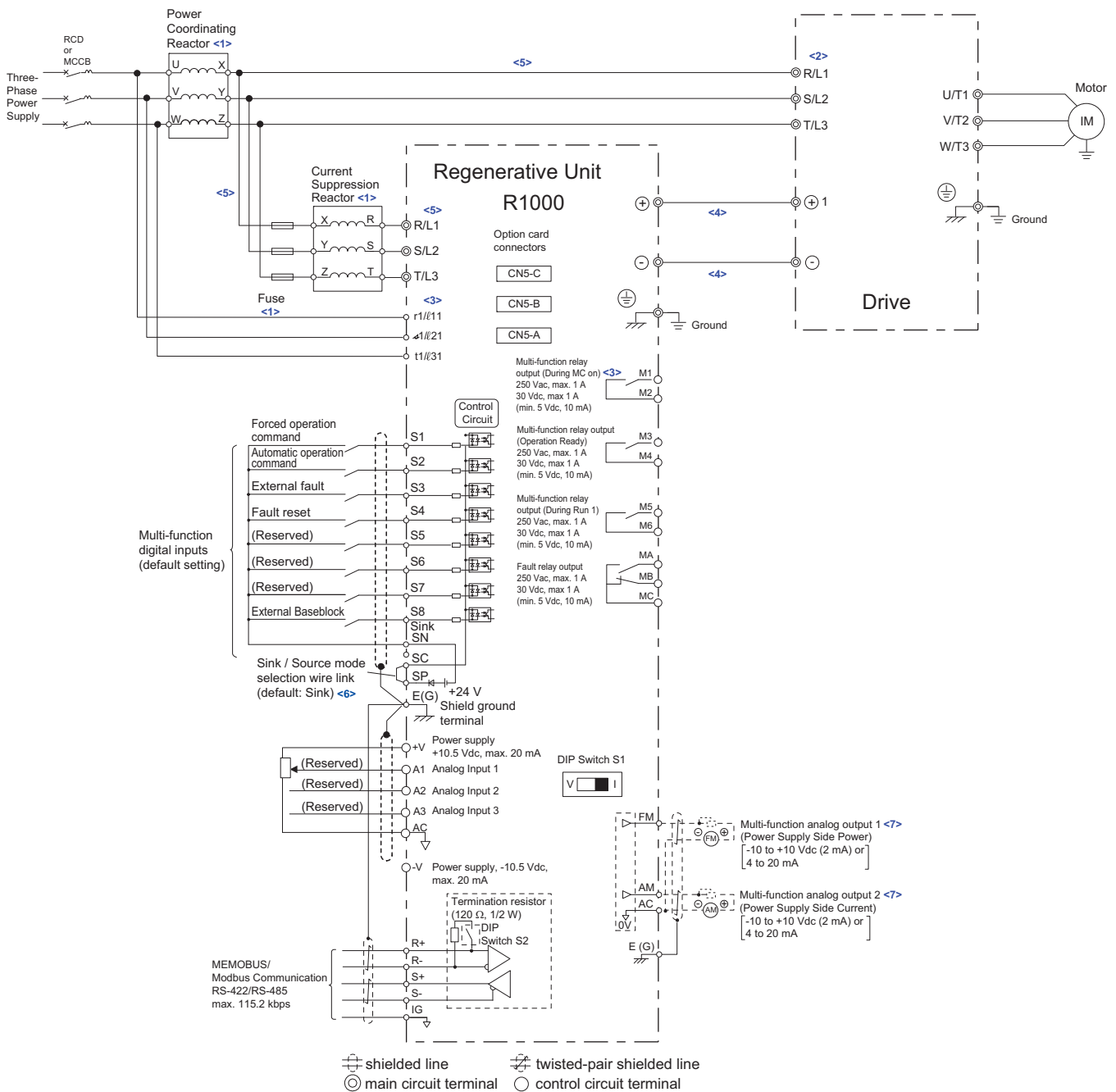

Figure 3.1 Standard Connection Diagram (example: model 2A0007)

- <1> Use the specified AC reactor and fuse. Non-specified devices may cause erroneous operation.
- <2> Always take the power supply for the drive's AC power supply terminals (R/L1, S/L2, and T/L3) from the secondary side of the power coordinating reactor.
- <3> Always take the power supply for the unit's power supply voltage detection inputs (r1/l11, a1/l21, and t1/l31) from the primary side of the power coordinating reactor.
- <4> Do not use a DC bus line that is longer than 5 m to connect the regenerative unit and drive.
- <5> Do not use a line longer than 10 m to connect the power coordinating reactor and the regenerative unit.
- <6> This figure shows an example of a sequence input to S1 through S8 using a non-powered relay or an NPN transistor. Install the wire link between terminals SC-SP for Sink mode and SC-SN for Source mode. Leave it out for external power supply. Never short terminals SP and SN as doing so will damage the regenerative unit.
- <7> Multi-function analog outputs work with devices such as analog frequency meters, ammeters, voltmeters, and wattmeters. They are not intended for use as a feedback-type signal.

## 3.3 Main Circuit Connection Diagram

Refer to diagrams in this section when wiring the main circuit of the regenerative unit. Connections may vary based on regenerative unit capacity. The DC power supply for the main circuit also provides power to the control circuit.

**NOTICE:** Do not use the negative DC bus terminal “⊖” as a ground terminal. This terminal is at high DC voltage potential. Improper wiring connections could damage the regenerative unit.

**Table 3.1 Connecting Main Circuit Terminals**

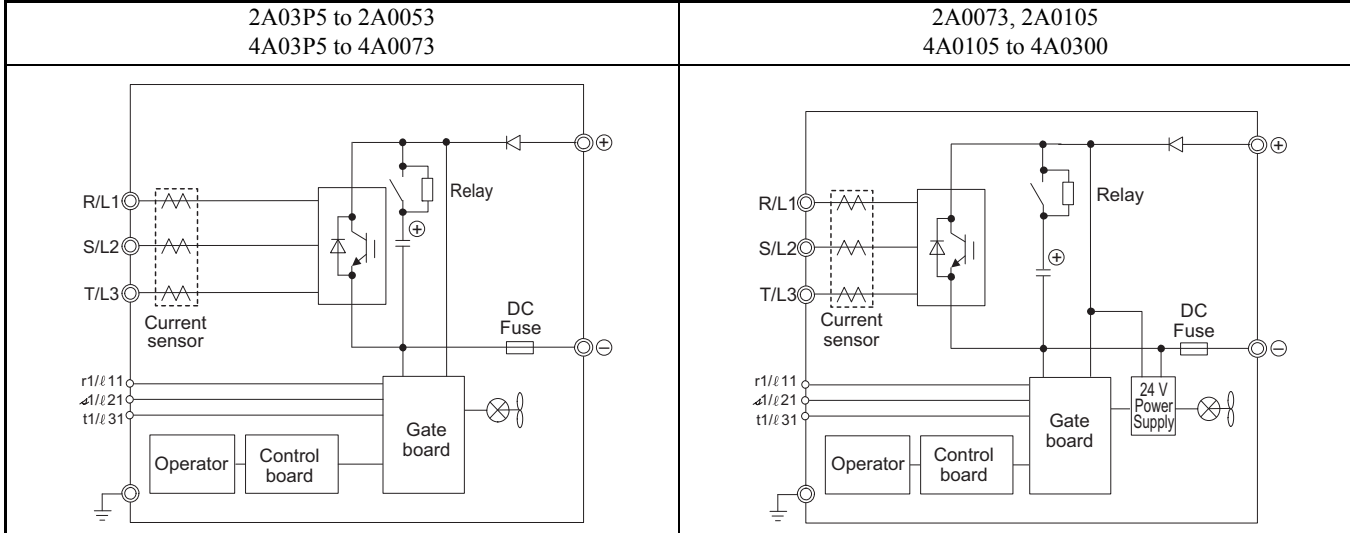

## 3.4 Terminal Block Configuration

Refer to the terminal block configuration diagrams in [Table 3.2](#) for the location of the main circuit terminal block.

**Table 3.2 Terminal Block Configuration**

Model	Figure	
200 V Class Models	2A03P5	<a href="#">Figure 3.2</a>
	2A0005	<a href="#">Figure 3.2</a>
	2A0007	<a href="#">Figure 3.2</a>
	2A0010	<a href="#">Figure 3.3</a>
	2A0014	<a href="#">Figure 3.3</a>
	2A0017	<a href="#">Figure 3.4</a>
	2A0020	<a href="#">Figure 3.4</a>
	2A0028	<a href="#">Figure 3.4</a>
	2A0035	<a href="#">Figure 3.5</a>
	2A0053	<a href="#">Figure 3.6</a>
	2A0073	<a href="#">Figure 3.8</a>
	2A0105	<a href="#">Figure 3.9</a>
400 V Class Models	4A03P5	<a href="#">Figure 3.2</a>
	4A0005	<a href="#">Figure 3.2</a>
	4A0007	<a href="#">Figure 3.2</a>
	4A0010	<a href="#">Figure 3.3</a>
	4A0014	<a href="#">Figure 3.3</a>
	4A0017	<a href="#">Figure 3.4</a>
	4A0020	<a href="#">Figure 3.4</a>
	4A0028	<a href="#">Figure 3.4</a>
	4A0035	<a href="#">Figure 3.5</a>
	4A0043	<a href="#">Figure 3.5</a>
	4A0053	<a href="#">Figure 3.7</a>
	4A0073	<a href="#">Figure 3.7</a>
	4A0105	<a href="#">Figure 3.8</a>
	4A0150	<a href="#">Figure 3.8</a>
	4A0210	<a href="#">Figure 3.9</a>
4A0300	<a href="#">Figure 3.9</a>	

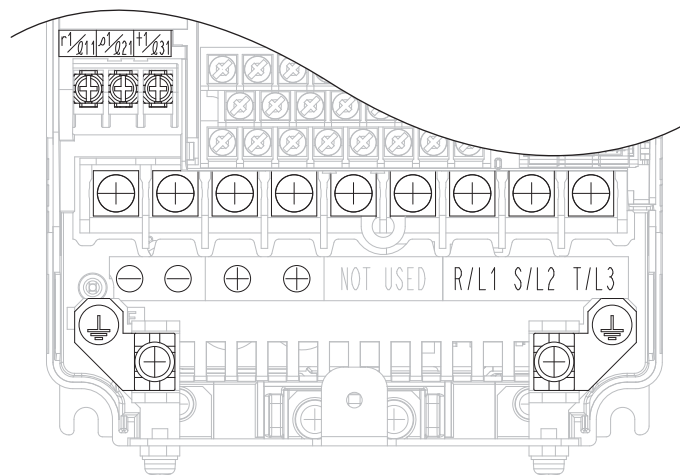

**Figure 3.2 Main Circuit Terminal Block Configuration (Models 2A03P5 to 2A0007, 4A03P5 to 4A0007)**

### 3.4 Terminal Block Configuration

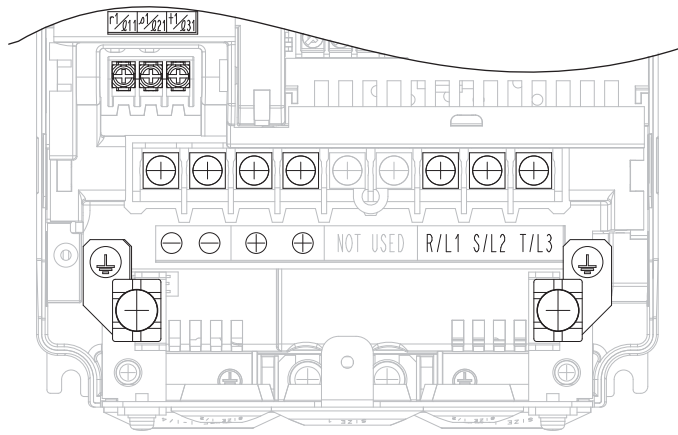

Figure 3.3 Main Circuit Terminal Block Configuration (Models 2A0010, 2A0014, 4A0010, 4A0014)

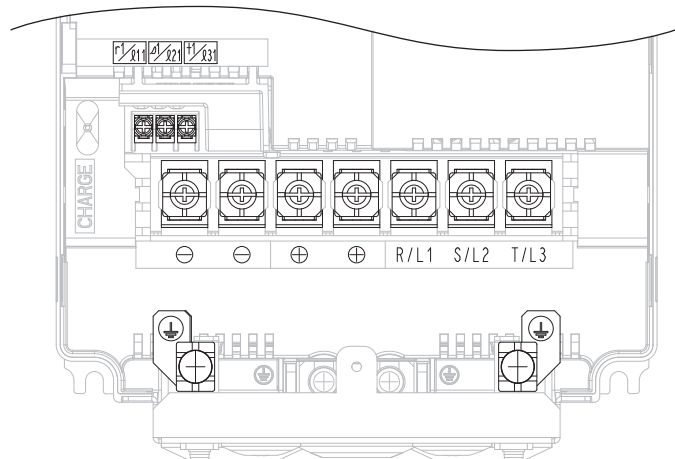

Figure 3.4 Main Circuit Terminal Block Configuration (Models 2A0017 to 2A0028, 4A0017 to 4A0028)

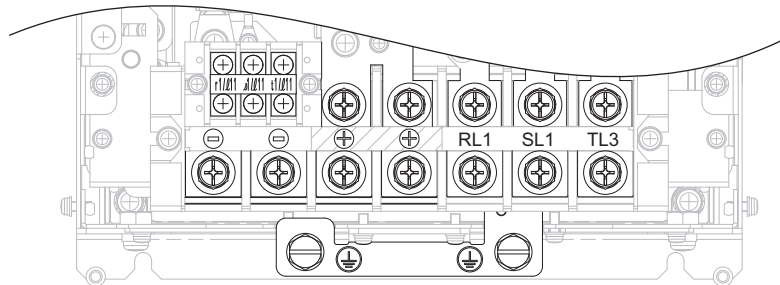

Figure 3.5 Main Circuit Terminal Block Configuration (Models 2A0035, 4A0035, 4A0043)

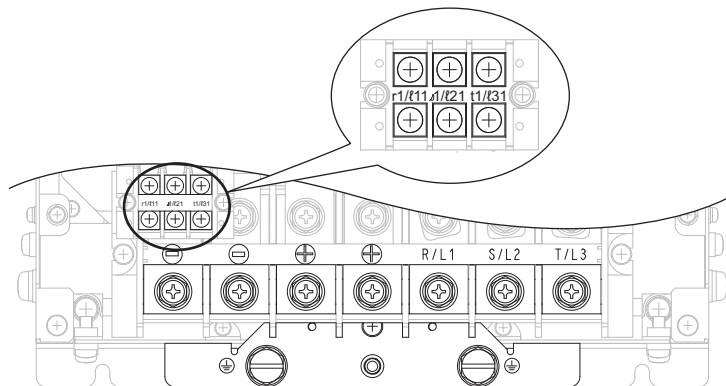

Figure 3.6 Main Circuit Terminal Block Configuration (Models 2A0053)



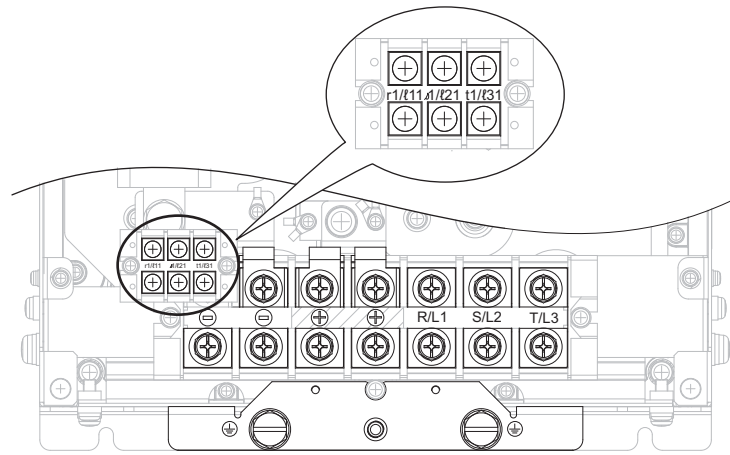

Figure 3.7 Main Circuit Terminal Block Configuration (Models 4A0053, 4A0073)

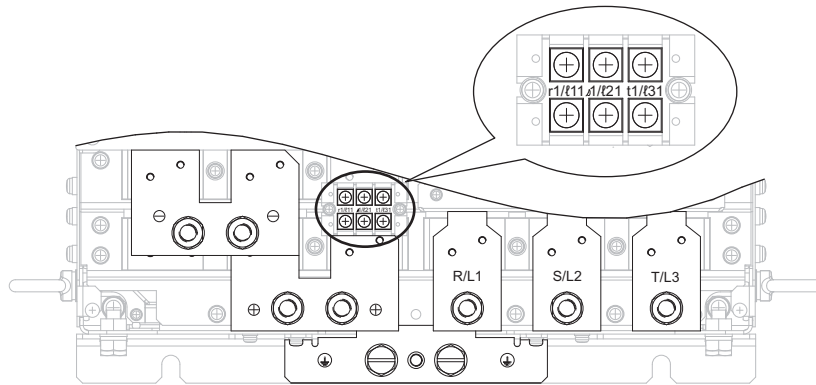

Figure 3.8 Main Circuit Terminal Block Configuration (Models 2A0073, 4A0105, 4A0150)

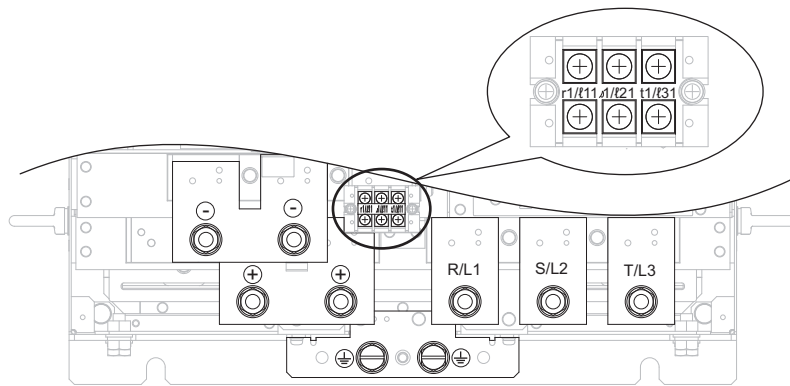

Figure 3.9 Main Circuit Terminal Block Configuration (Models 2A0105, 4A0210, 4A0300)

## 3.5 Terminal Cover

Follow the procedure below to remove the terminal cover for wiring and to reattach the terminal cover after wiring is complete.

### ◆ Models 2A03P5 to 2A0028, 4A03P5 to 4A0028 (IP20/NEMA Type 1)

#### ■ Removing the Terminal Cover

Loosen the terminal cover screw using a #2 Phillips screwdriver. Screw sizes vary by regenerative unit model. Then, push in on the tab located on the bottom of the terminal cover and gently pull forward to remove the terminal cover.

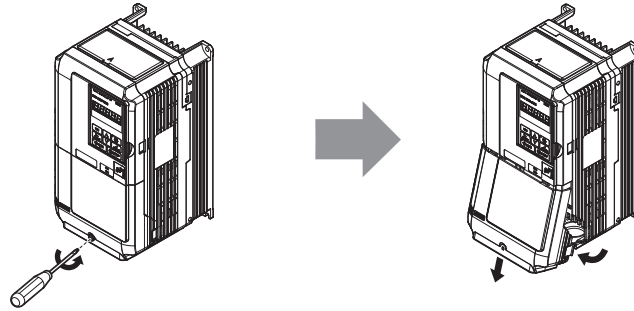
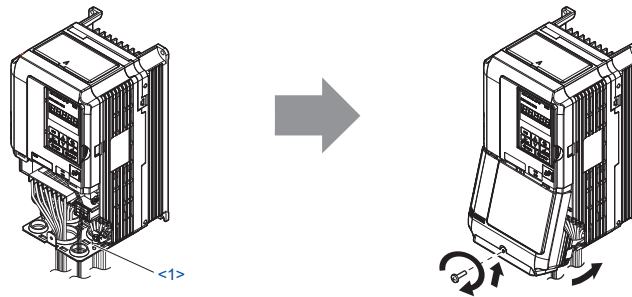

Figure 3.10 Removing the Terminal Cover on an IP20/NEMA Type 1 Enclosure Model

#### ■ Reattaching the Terminal Cover

Power lines and signal wiring should pass through the opening provided. Refer to [Wiring the Main Circuit Terminal on page 47](#) and [Wiring the Control Circuit Terminal on page 51](#) for details on wiring.

Reattach the terminal cover after completing the wiring to the regenerative unit and other devices.



<1> Connect ground wiring first, followed by the main circuit, and then wire the control circuit. Power lines and signal wiring exit through the opening provided.

Figure 3.11 Reattaching the Terminal Cover on an IP20/NEMA Type 1 Enclosure Model

## ◆ Models 2A0035 to 2A0105, 4A0035 to 4A0300 (IP00/Open Type enclosure)

### ■ Removing the Terminal Cover

1. Loosen the screws on the terminal cover, then pull forward on the terminal cover to free it from the regenerative unit.

**Note:** Models 2A0073, 2A0105, and 4A0105 to 4A0300 have three mounting screws above the terminal cover.

**CAUTION!** Do not completely remove the cover screws, just loosen them. If the cover screws are removed completely, the terminal cover may fall off causing an injury.

Larger capacity regenerative units have large and heavy terminal covers. Remove and attach these covers with care.

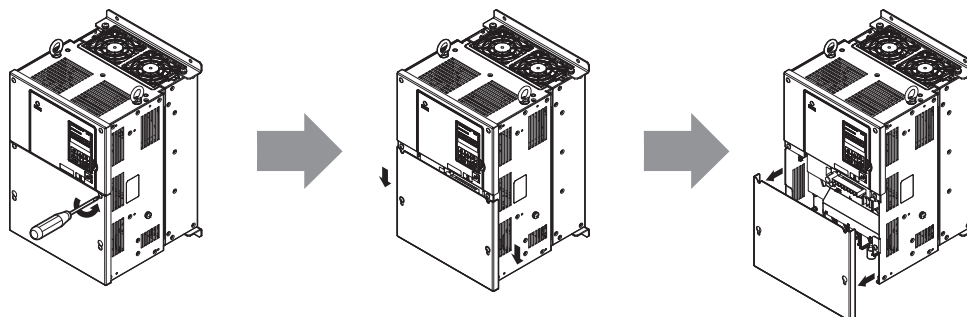
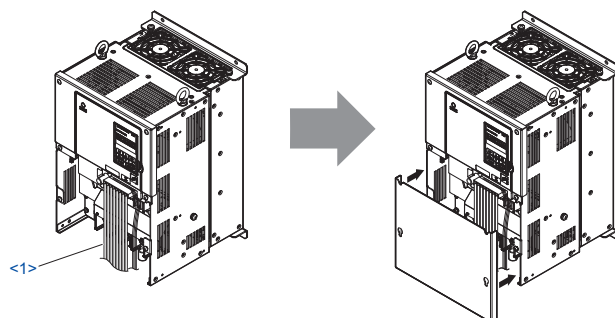

Figure 3.12 Removing the Terminal Cover on an IP00/Open Type enclosure Model

### ■ Reattaching the Terminal Cover

After wiring the terminal board and other devices, double-check connections and reattach the terminal cover. Refer to [Wiring the Main Circuit Terminal on page 47](#) and [Wiring the Control Circuit Terminal on page 51](#) for details on wiring.



- <1> Connect ground wiring first, followed by the main circuit, and then wire the control circuit. Power lines and signal wiring exit through the opening provided.

Figure 3.13 Reattaching the Terminal Cover on an IP00/Open Type enclosure Model

## 3.6 Digital Operator and Front Cover

**NOTICE:** Be sure to remove the digital operator prior to opening or reattaching the front cover. Leaving the digital operator plugged into the regenerative unit when removing the front cover can result in erroneous operation caused by a poor connection. Firmly fasten the front cover back into place before reattaching the digital operator.

Detach the digital operator from the regenerative unit for remote operation or when opening the front cover to install an option card.

### ◆ Removing/Reattaching the Digital Operator

While pressing on the tab located on the right side of the digital operator, pull the digital operator forward to remove it from the regenerative unit.

Insert the digital operator into the opening in the top cover while aligning it with the notches on the left side of the opening. Next, press gently on the right side of the operator until it clicks into place.

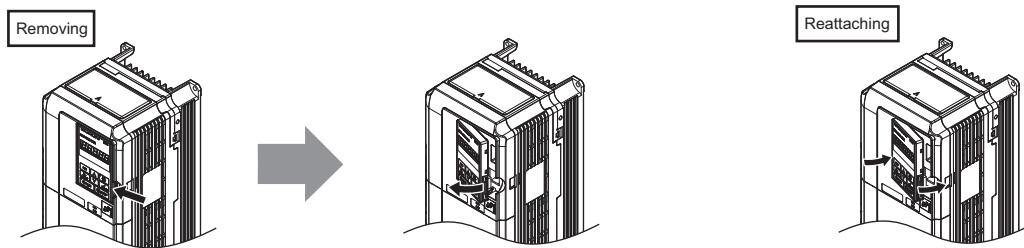

Figure 3.14 Removing/Reattaching the Digital Operator

### ◆ Removing/Reattaching the Front Cover

#### ■ Removing the Front Cover

##### Models 2A03P5 to 2A0028, and 4A03P5 to 4A0028

After removing the terminal cover and the digital operator, loosen the screw that affixes the front cover (models 2A03P5 to 2A0007, and 4A03P5 to 4A0007 do not use a screw to affix the front cover). Pinch in on the tabs found on each side of the front cover, then pull forward to remove it from the regenerative unit.

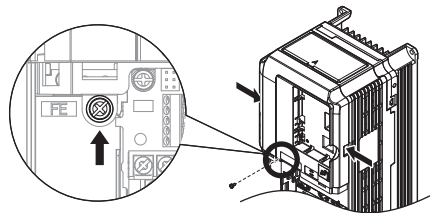
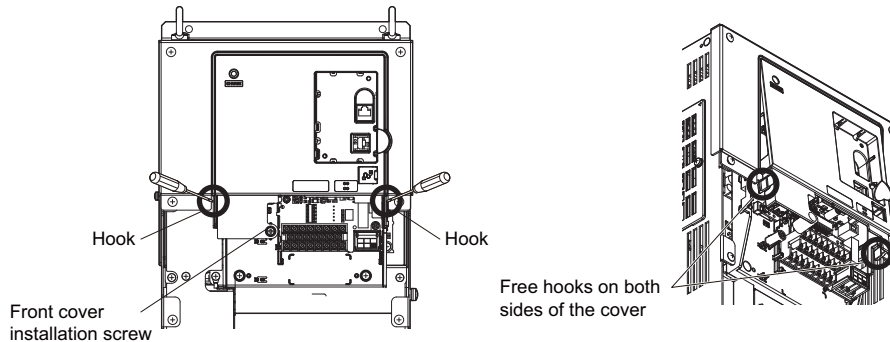

Figure 3.15 Remove the Front Cover (2A03P5 to 2A0028, 4A03P5 to 4A0028)

**Models 2A0035 to 2A0105, and 4A0035 to 4A0300**

1. Remove the terminal cover and the digital operator.
2. Loosen the installation screw on the front cover.
3. Use a straight-edge screwdriver to loosen the hooks on each side of the cover that hold it in place.



**Figure 3.16 Remove the Front Cover (2A0035 to 2A0105, and 4A0035 to 4A0300)**

4. Unhook the left side of the front cover then swing the left side towards you as shown in [Figure 3.14](#) until the cover comes off.

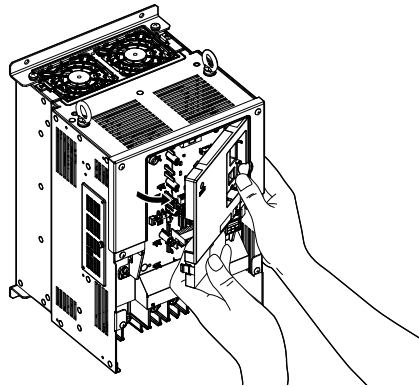

**Figure 3.17 Remove the Front Cover (2A0035 to 2A0105, and 4A0035 to 4A0300)**

### ■ Reattaching the Front Cover

#### Models 2A03P5 to 2A0028, 4A03P5 to 4A0028

Reverse the instructions given in [Models 2A03P5 to 2A0028, 4A03P5 to 4A0028 \(IP20/NEMA Type 1\) on page 38](#) to reattach the front cover. Pinch inwards on the hooks found on each side of the front cover while guiding it back into the regenerative unit. Make sure it clicks firmly into place.

#### Models 2A0035 to 2A0105, and 4A0035 to 4A0300

1. Slide the front cover so the hooks on the top connect to the regenerative unit.

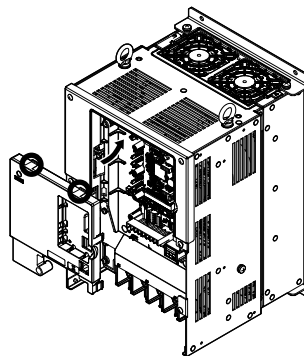

**Figure 3.18 Reattach the Front Cover (2A0035 to 2A0105, and 4A0035 to 4A0300)**

2. After connecting the hooks to the regenerative unit, press firmly on the cover to lock it into place.

## 3.7 Top Protective Cover

Models 2A03P5 to 2A0028, 4A03P5 to 4A0028 are designed to IP20/NEMA Type 1 specifications with a protective cover on the top. Removing this top protective cover or the bottom conduit bracket from an IP20/NEMA Type 1 enclosure models voids the NEMA Type 1 protection while maintaining IP20 conformity.

### ◆ Removing and Reattaching the Top Protective Cover

Insert the tip of a straight-edge screwdriver into the small opening located on the front edge of the top protective cover. Gently apply pressure as shown in the figure below to free the cover from the regenerative unit. Insert the two small protruding hooks on the rear side of the top protective cover into the provided mounting holes near the back of the regenerative unit, then press down on the front side of the top protective cover to fasten the cover into place.

**Note:** Removing the top protective cover or the bottom conduit bracket from an IP20/NEMA Type 1 enclosure drive voids the NEMA Type 1 protection while maintaining IP20 conformity.

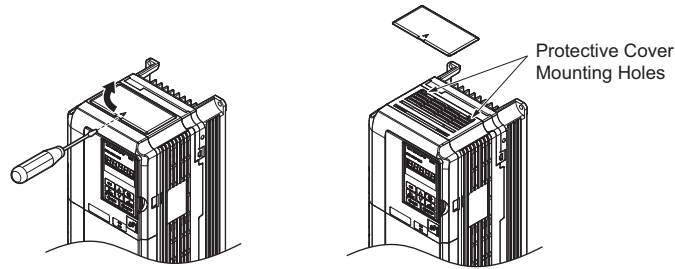

Figure 3.19 Removing and Reattaching the Top Protective Cover

## 3.8 Main Circuit Wiring

This section describes the functions, specifications, and procedures required to safely and properly wire the main circuit in the regenerative unit.

**NOTICE:** Do not switch the regenerative unit input power supply on and off frequently. Frequently switching the unit on and off shortens the life of the DC bus capacitors, and can cause premature unit failure. For the full performance life, refrain from switching the unit on and off more than once every 30 minutes.

**NOTICE:** Do not solder the ends of wire connections to the regenerative unit. Soldered wiring connections can loosen over time. Improper wiring practices could result in regenerative unit malfunction due to loose terminal connections.

### ◆ Main Circuit Terminal Functions

Table 3.3 Main Circuit Terminal Functions

Terminal		Type	Function	Page
200 V Class	Model	2A03P5 to 2A0105		
400 V Class		4A03P5 to 4A0300		
R/L1		Main circuit power supply input	These are the power supply input terminals that connect to the input reactor.	32
S/L2				
T/L3				
r1/ℓ11		Power supply voltage detection inputs	These terminals are to detect the power supply voltage order and voltage levels.	32
s1/ℓ21				
t1/ℓ31				
⊖		DC voltage input	These terminals input a DC voltage	–
⊕				
⊕		–	Grounding terminal	46

### ◆ Protecting Main Circuit Terminals

#### ■ Insulation Caps or Sleeves

Use insulation caps or sleeves when wiring the regenerative unit with crimp terminals. Take particular care to ensure that the wiring does not touch nearby terminals or the surrounding case.

### ◆ Wire Gauges and Tightening Torque

Use the tables in this section to select the appropriate wires and crimp terminals.

- Note:**
1. Wire gauge recommendations based on continuous current ratings using 75°C 600 Vac vinyl-sheathed wire assuming ambient temperature within 40°C.
  2. Use terminals ⊕ and ⊖ when connecting the drive to the regenerative unit.

Consider the amount of voltage drop when selecting wire gauges. Increase the wire gauge when the voltage drop is greater than 2% of motor rated voltage. Ensure the wire gauge is suitable for the terminal block. Use the following formula to calculate the amount of voltage drop:

$$\text{Line drop voltage (V)} = \sqrt{3} \times \text{wire resistance } (\Omega/\text{km}) \times \text{wire length (m)} \times \text{current (A)} \times 10^{-3}$$

Refer to [UL Standards Compliance on page 191](#) for information on UL compliance.

The wire gauges listed in [Table 3.4](#) and [Table 3.5](#) are Yaskawa recommendations. Refer to local codes for proper wire gauge selections.

### 3.8 Main Circuit Wiring

#### ■ Three-Phase 200 V Class

Table 3.4 Wire Gauge and Torque Specifications (Three-Phase 200 V Class)

Model	Terminal	For Asia <→>		For U.S.A. <→>		For Europe and China <→>		Screw Size	Tightening Torque N·m
		Recomm. Gauge mm <sup>2</sup>	Applicable Gauge mm <sup>2</sup>	Recomm. Gauge AWG	Applicable Gauge AWG	Recomm. Gauge mm <sup>2</sup>	Applicable Gauge mm <sup>2</sup>		
2A03P5	R/L1,S/L2,T/L3	3.5	3.5 to 14	12	12 to 6	4	4 to 16	M4	2.1 to 2.3
	⊖, ⊕	3.5	3.5 to 14	12	12 to 6	4	4 to 16	M4	2.1 to 2.3
	r1/ℓ11, Ⓛ1/ℓ21,t1/ℓ31	2	2	14	14	2.5	2.5	M3.5	0.8 to 1.0
	⊕	2	2 to 8	12	12 to 8	4	4 to 10	M5	2.0 to 2.5
2A0005	R/L1,S/L2,T/L3	3.5	3.5 to 14	12	12 to 6	4	4 to 16	M4	2.1 to 2.3
	⊖, ⊕	3.5	3.5 to 14	10	10 to 6	4	4 to 16	M4	2.1 to 2.3
	r1/ℓ11, Ⓛ1/ℓ21,t1/ℓ31	2	2	14	14	2.5	2.5	M3.5	0.8 to 1.0
	⊕	2	2 to 8	12	12 to 8	4	4 to 10	M5	2.0 to 2.5
2A0007	R/L1,S/L2,T/L3	3.5	3.5 to 14	12	12 to 6	4	4 to 16	M4	2.1 to 2.3
	⊖, ⊕	3.5	3.5 to 14	10	10 to 6	4	4 to 16	M4	2.1 to 2.3
	r1/ℓ11, Ⓛ1/ℓ21,t1/ℓ31	2	2	14	14	2.5	2.5	M3.5	0.8 to 1.0
	⊕	3.5	3.5 to 8	10	10 to 8	4	4 to 10	M5	2.0 to 2.5
2A0010	R/L1,S/L2,T/L3	5.5	5.5 to 14	10	10 to 6	4	4 to 16	M4	2.1 to 2.3
	⊖, ⊕	14	14	6	6	16	16	M4	2.1 to 2.3
	r1/ℓ11, Ⓛ1/ℓ21,t1/ℓ31	2	2	14	14	2.5	2.5	M3.5	0.8 to 1.0
	⊕	5.5	5.5 to 14	8	8 to 6	4	4 to 16	M6	2.0 to 2.5
2A0014	R/L1,S/L2,T/L3	8	8 to 14	8	8 to 6	6	6 to 16	M4	2.1 to 2.3
	⊖, ⊕	14	14	6	6	16	16	M4	2.1 to 2.3
	r1/ℓ11, Ⓛ1/ℓ21,t1/ℓ31	2	2	14	14	2.5	2.5	M3.5	0.8 to 1.0
	⊕	5.5	5.5 to 14	8	8 to 6	6	6 to 16	M6	2.0 to 2.5
2A0017	R/L1,S/L2,T/L3	14	14 to 38	8	8 to 1	10	10 to 25	M6	3.6 to 4.0
	⊖, ⊕	14	14 to 38	4	4 to 1	16	16 to 25	M6	3.6 to 4.0
	r1/ℓ11, Ⓛ1/ℓ21,t1/ℓ31	2	2	14	14	2.5	2.5	M3.5	0.8 to 1.0
	⊕	5.5	5.5 to 22	8	8 to 4	10	10 to 25	M6	5.4 to 6.0
2A0020	R/L1,S/L2,T/L3	14	14 to 38	6	6 to 1	10	10 to 25	M6	3.6 to 4.0
	⊖, ⊕	22	22 to 38	4	4 to 1	16	16 to 25	M6	3.6 to 4.0
	r1/ℓ11, Ⓛ1/ℓ21,t1/ℓ31	2	2	14	14	2.5	2.5	M3.5	0.8 to 1.0
	⊕	8	8 to 22	6	6 to 4	10	10 to 25	M6	5.4 to 6.0
2A0028	R/L1,S/L2,T/L3	22	22 to 38	4	4 to 1	16	16 to 35	M6	3.6 to 4.0
	⊖, ⊕	30	30 to 38	2	2 to 1	25	25 to 35	M6	3.6 to 4.0
	r1/ℓ11, Ⓛ1/ℓ21,t1/ℓ31	2	2	14	14	2.5	2.5	M3.5	0.8 to 1.0
	⊕	14	14 to 22	6	6 to 4	16	16 to 25	M6	5.4 to 6.0
2A0035	R/L1,S/L2,T/L3	38	38 to 70	2	2 to 2/0	25	25 to 70	M8	5.4 to 6.0
	⊖, ⊕	38	38 to 70	1/0	1/0 to 2/0	35	35 to 70	M8	5.4 to 6.0
	r1/ℓ11, Ⓛ1/ℓ21,t1/ℓ31	2	2 to 5.5	14	14 to 10	2.5	2.5 to 6	M4	1.1 to 1.2
	⊕	22	22	4	4	16	16 to 25	M8	9.0 to 11.0
2A0053	R/L1,S/L2,T/L3	50	50 to 150	2/0	2/0 to 250	50	50 to 95	M8	13.5 to 15.0
	⊖, ⊕	80	80 to 150	4/0	4/0 to 250	70	70 to 95	M8	13.5 to 15.0
	r1/ℓ11, Ⓛ1/ℓ21,t1/ℓ31	2	2 to 5.5	14	14 to 10	2.5	2.5 to 6	M4	1.1 to 1.2
	⊕	22	22 to 60	3	3 to 2	25	25 to 35	M10	18.0 to 23.0
2A0073	R/L1,S/L2,T/L3	80	80 to 150	1/0 × 2P	1/0 to 300	70	70 to 150	M12	32.0 to 40.0
	⊖, ⊕	125	125 to 150	3/0 × 2P	3/0 to 300	120	120 to 150	M12	32.0 to 40.0
	r1/ℓ11, Ⓛ1/ℓ21,t1/ℓ31	2	2 to 5.5	14	14 to 10	2.5	2.5 to 6	M4	1.1 to 1.2
	⊕	60	60 to 150	1/0	1/0 to 300	35	35 to 150	M12	32.0 to 40.0



Model	Terminal	For Asia <1>		For U.S.A. <2>		For Europe and China <3>		Screw Size	Tightening Torque N·m
		Recomm. Gauge mm <sup>2</sup>	Applicable Gauge mm <sup>2</sup>	Recomm. Gauge AWG	Applicable Gauge AWG	Recomm. Gauge mm <sup>2</sup>	Applicable Gauge mm <sup>2</sup>		
2A0105	R/L1,S/L2,T/L3	80 × 2P	80 to 325	3/0 × 2P	3/0 to 600	95 × 2P	95 to 240	M12	32.0 to 40.0
	⊖, ⊕	150 × 2P	150 to 325	300 × 2P	300 to 600	150 × 2P	150 to 240	M12	32.0 to 40.0
	r1/ℓ11, s1/ℓ21,t1/ℓ31	2	2 to 5.5	14	14 to 10	2.5	2.5 to 6	M4	1.1 to 1.2
	⊕	60	60 to 180	1/0	1/0 to 300	70	70 to 240	M12	32.0 to 40.0

<1> Gauges listed here are for use in Japan.

<2> Gauges listed here are for use in the United States.

<3> Gauges listed here are for use in Europe and China.

Table 3.5 Three-Phase 400 V Class

Model	Terminal	For Asia <1>		For U.S.A. <2>		For Europe and China <3>		Screw Size	Tightening Torque N·m
		Recomm. Gauge mm <sup>2</sup>	Applicable Gauge mm <sup>2</sup>	Recomm. Gauge AWG	Applicable Gauge AWG	Recomm. Gauge mm <sup>2</sup>	Applicable Gauge mm <sup>2</sup>		
4A03P5	R/L1,S/L2,T/L3	3.5	3.5 to 14	10	10 to 6	4	4 to 16	M4	2.1 to 2.3
	⊖, ⊕	3.5	3.5 to 14	12	12 to 6	4	4 to 16	M4	2.1 to 2.3
	r1/ℓ11, s1/ℓ21,t1/ℓ31	2	2	14	14	2.5	2.5	M3.5	0.8 to 1.0
	⊕	2	2 to 8	12	12 to 10	4	4 to 6	M5	2.0 to 2.5
4A0005	R/L1,S/L2,T/L3	3.5	3.5 to 14	10	10 to 6	4	4 to 16	M4	2.1 to 2.3
	⊖, ⊕	3.5	3.5 to 14	12	12 to 6	4	4 to 16	M4	2.1 to 2.3
	r1/ℓ11, s1/ℓ21,t1/ℓ31	2	2	14	14	2.5	2.5	M3.5	0.8 to 1.0
	⊕	2	2 to 8	12	12 to 10	4	4 to 6	M5	2.0 to 2.5
4A0007	R/L1,S/L2,T/L3	3.5	3.5 to 14	12	12 to 6	4	4 to 16	M4	2.1 to 2.3
	⊖, ⊕	3.5	3.5 to 14	12	12 to 6	4	4 to 16	M4	2.1 to 2.3
	r1/ℓ11, s1/ℓ21,t1/ℓ31	2	2	14	14	2.5	2.5	M3.5	0.8 to 1.0
	⊕	2	2 to 8	10	10	4	4 to 6	M5	2.0 to 2.5
4A0010	R/L1,S/L2,T/L3	3.5	3.5 to 14	12	12 to 6	4	4 to 16	M4	2.1 to 2.3
	⊖, ⊕	5.5	5.5 to 14	10	10 to 6	6	6 to 16	M4	2.1 to 2.3
	r1/ℓ11, s1/ℓ21,t1/ℓ31	2	2	14	14	2.5	2.5	M3.5	0.8 to 1.0
	⊕	3.5	3.5 to 14	10	10 to 6	4	4 to 16	M6	2.0 to 2.5
4A0014	R/L1,S/L2,T/L3	3.5	3.5 to 14	10	10 to 6	4	4 to 16	M4	2.1 to 2.3
	⊖, ⊕	5.5	5.5 to 14	10	10 to 6	6	6 to 16	M4	2.1 to 2.3
	r1/ℓ11, s1/ℓ21,t1/ℓ31	2	2	14	14	2.5	2.5	M3.5	0.8 to 1.0
	⊕	3.5	3.5 to 14	10	10 to 6	4	4 to 16	M6	2.0 to 2.5
4A0017	R/L1,S/L2,T/L3	8	8 to 38	10	10 to 1	10	10 to 25	M6	3.6 to 4.0
	⊖, ⊕	14	14 to 38	6	6 to 1	16	16 to 25	M6	3.6 to 4.0
	r1/ℓ11, s1/ℓ21,t1/ℓ31	2	2	14	14	2.5	2.5	M3.5	0.8 to 1.0
	⊕	5.5	5.5 to 22	8	8 to 6	10	10 to 16	M6	5.4 to 6.0
4A0020	R/L1,S/L2,T/L3	8	8 to 38	8	8 to 1	10	10 to 25	M6	3.6 to 4.0
	⊖, ⊕	14	14 to 38	6	6 to 1	16	16 to 25	M6	3.6 to 4.0
	r1/ℓ11, s1/ℓ21,t1/ℓ31	2	2	14	14	2.5	2.5	M3.5	0.8 to 1.0
	⊕	5.5	5.5 to 22	8	8 to 6	10	10 to 16	M6	5.4 to 6.0
4A0028	R/L1,S/L2,T/L3	8	8 to 38	8	8 to 1	10	10 to 25	M6	3.6 to 4.0
	⊖, ⊕	14	14 to 38	6	6 to 1	16	16 to 25	M6	3.6 to 4.0
	r1/ℓ11, s1/ℓ21,t1/ℓ31	2	2	14	14	2.5	2.5	M3.5	0.8 to 1.0
	⊕	5.5	5.5 to 22	8	8 to 6	10	10 to 16	M6	5.4 to 6.0
4A0035	R/L1,S/L2,T/L3	14	14 to 70	6	6 to 2/0	10	10 to 70	M8	5.4 to 6.0
	⊖, ⊕	14	14 to 70	3	3 to 2/0	16	16 to 70	M8	5.4 to 6.0
	r1/ℓ11, s1/ℓ21,t1/ℓ31	2	2 to 5.5	14	14 to 10	2.5	2.5 to 6	M4	1.1 to 1.2
	⊕	8	8 to 22	6	6	10	10 to 16	M8	9.0 to 11.0

### 3.8 Main Circuit Wiring

Model	Terminal	For Asia <1>		For U.S.A. <2>		For Europe and China <3>		Screw Size	Tightening Torque N·m
		Recomm. Gauge mm <sup>2</sup>	Applicable Gauge mm <sup>2</sup>	Recomm. Gauge AWG	Applicable Gauge AWG	Recomm. Gauge mm <sup>2</sup>	Applicable Gauge mm <sup>2</sup>		
4A0043	R/L1,S/L2,T/L3	14	14 to 70	4	4 to 2/0	10	10 to 70	M8	5.4 to 6.0
	⊖, ⊕	22	22 to 70	2	2 to 2/0	16	16 to 70	M8	5.4 to 6.0
	r1/ℓ11, Ⓛ1/ℓ21,t1/ℓ31	2	2 to 5.5	14	14 to 10	2.5	2.5 to 6	M4	1.1 to 1.2
	⊕	14	14 to 22	6	6	10	10 to 16	M8	9.0 to 11.0
4A0053	R/L1,S/L2,T/L3	22	22 to 70	4	4 to 2/0	16	16 to 70	M8	5.4 to 6.0
	⊖, ⊕	30	30 to 70	2	2 to 2/0	25	25 to 70	M8	5.4 to 6.0
	r1/ℓ11, Ⓛ1/ℓ21,t1/ℓ31	2	2 to 5.5	14	14 to 10	2.5	2.5 to 6	M4	1.1 to 1.2
	⊕	14	14 to 60	6	6 to 4	16	16 to 25	M10	18.0 to 23.0
4A0073	R/L1,S/L2,T/L3	30	30 to 70	2	2 to 2/0	25	25 to 70	M8	5.4 to 6.0
	⊖, ⊕	50	50 to 70	1/0	1/0 to 2/0	50	50 to 70	M8	5.4 to 6.0
	r1/ℓ11, Ⓛ1/ℓ21,t1/ℓ31	2	2 to 5.5	14	14 to 10	2.5	2.5 to 6	M4	1.1 to 1.2
	⊕	22	22 to 60	4	4	16	16 to 25	M10	18.0 to 23.0
4A0105	R/L1,S/L2,T/L3	50	50 to 150	2/0	2/0 to 300	50	50 to 150	M10	18.0 to 23.0
	⊖, ⊕	80	80 to 150	4/0	4/0 to 300	70	70 to 150	M10	18.0 to 23.0
	r1/ℓ11, Ⓛ1/ℓ21,t1/ℓ31	2	2 to 5.5	14	14 to 10	2.5	2.5 to 6	M4	1.1 to 1.2
	⊕	38	38 to 150	1	1 to 300	25	25 to 150	M10	18.0 to 23.0
4A0150	R/L1,S/L2,T/L3	100	100 to 150	250	250 to 300	95	95 to 240	M12	32.0 to 40.0
	⊖, ⊕	150	150 to 325	3/0 × 2P	3/0 to 600	150	150 to 240	M12	32.0 to 40.0
	r1/ℓ11, Ⓛ1/ℓ21,t1/ℓ31	2	2 to 5.5	14	14 to 10	2.5	2.5 to 6	M4	1.1 to 1.2
	⊕	60	60 to 150	1/0	1/0 to 300	25	25 to 150	M12	32.0 to 40.0
4A0210	R/L1,S/L2,T/L3	80 × 2P	80 to 325	3/0 × 2P	3/0 to 600	95 × 2P	95 to 240	M12	32.0 to 40.0
	⊖, ⊕	80 × 2P	80 to 325	4/0 × 2P	4/0 to 600	95 × 2P	95 to 150	M12	32.0 to 40.0
	r1/ℓ11, Ⓛ1/ℓ21,t1/ℓ31	2	2 to 5.5	14	14 to 10	2.5	2.5 to 6	M4	1.1 to 1.2
	⊕	60	60 to 180	2/0	2/0 to 350	95	95 to 240	M12	32.0 to 40.0
4A0300	R/L1,S/L2,T/L3	100 × 2P	100 to 325	250 × 2P	250 to 600	95 × 2P	95 to 240	M12	32.0 to 40.0
	⊖, ⊕	150 × 2P	150 to 325	400 × 2P	400 to 600	120 × 2P	120 to 150	M12	32.0 to 40.0
	r1/ℓ11, Ⓛ1/ℓ21,t1/ℓ31	2	2 to 5.5	14	14 to 10	2.5	2.5 to 6	M4	1.1 to 1.2
	⊕	60 × 2P	60 to 180	4/0	4/0 to 350	95	95 to 240	M12	32.0 to 40.0

<1> Gauges listed here are for use in Japan.

<2> Gauges listed here are for use in the United States.

<3> Gauges listed here are for use in Europe and China.

### ◆ Ground Wiring

Follow the precautions below when wiring the ground for one regenerative unit or a series of regenerative units.

**WARNING! Electrical Shock Hazard.** Always use a ground wire that complies with technical standards on electrical equipment and minimize the length of the ground wire. Improper equipment grounding may cause dangerous electrical potentials on equipment chassis, which could result in death or serious injury.

**WARNING! Electrical Shock Hazard.** Be sure to ground the regenerative unit ground terminal (200 V class: ground to 100 Ω or less; 400 V class: ground to 10 Ω or less). Improper equipment grounding could result in death or serious injury by contacting ungrounded electrical equipment.

**NOTICE:** Do not share the ground wire with other devices such as welding machines or large-current electrical equipment. Improper equipment grounding could result in regenerative unit or equipment malfunction due to electrical interference.

**NOTICE:** When using more than one regenerative unit, ground multiple regenerative units according to instructions. Improper equipment grounding could result in abnormal operation of regenerative unit or equipment.

**NOTICE:** If devices, such as office equipment, that is sensitive to noise are installed in the same location, separate the ground wires and use independent grounds or noise filters to prevent noise from entering the devices through the ground wire. Otherwise, the office equipment may fail.

- Note:**
1. Connect the regenerative units to power supply transformers on a 1:1 basis and use independent grounds. Otherwise the regenerative units or the devices may fail to operate.
  2. If other devices are installed in the same location, connect them while observing the grounding standards for each device. Otherwise the regenerative units or the devices may fail to operate.

Do not loop the ground wire of the regenerative unit and the drive.

### ■ Wiring the Main Circuit Terminal

**WARNING!** *Electrical Shock Hazard. Shut off the power supply to the regenerative unit before wiring the main circuit terminals. Failure to comply may result in death or serious injury.*

Wire the main circuit terminals after the terminal board has been properly grounded.

### ■ Main Circuit Connection Diagram

Refer to [Main Circuit Connection Diagram on page 34](#) when wiring terminals on the main power circuit of the regenerative unit.

# 3.9 Control Circuit Wiring

**NOTICE:** Do not connect AC control circuit ground to regenerative unit enclosure. Improper regenerative unit grounding can cause control circuit malfunction.

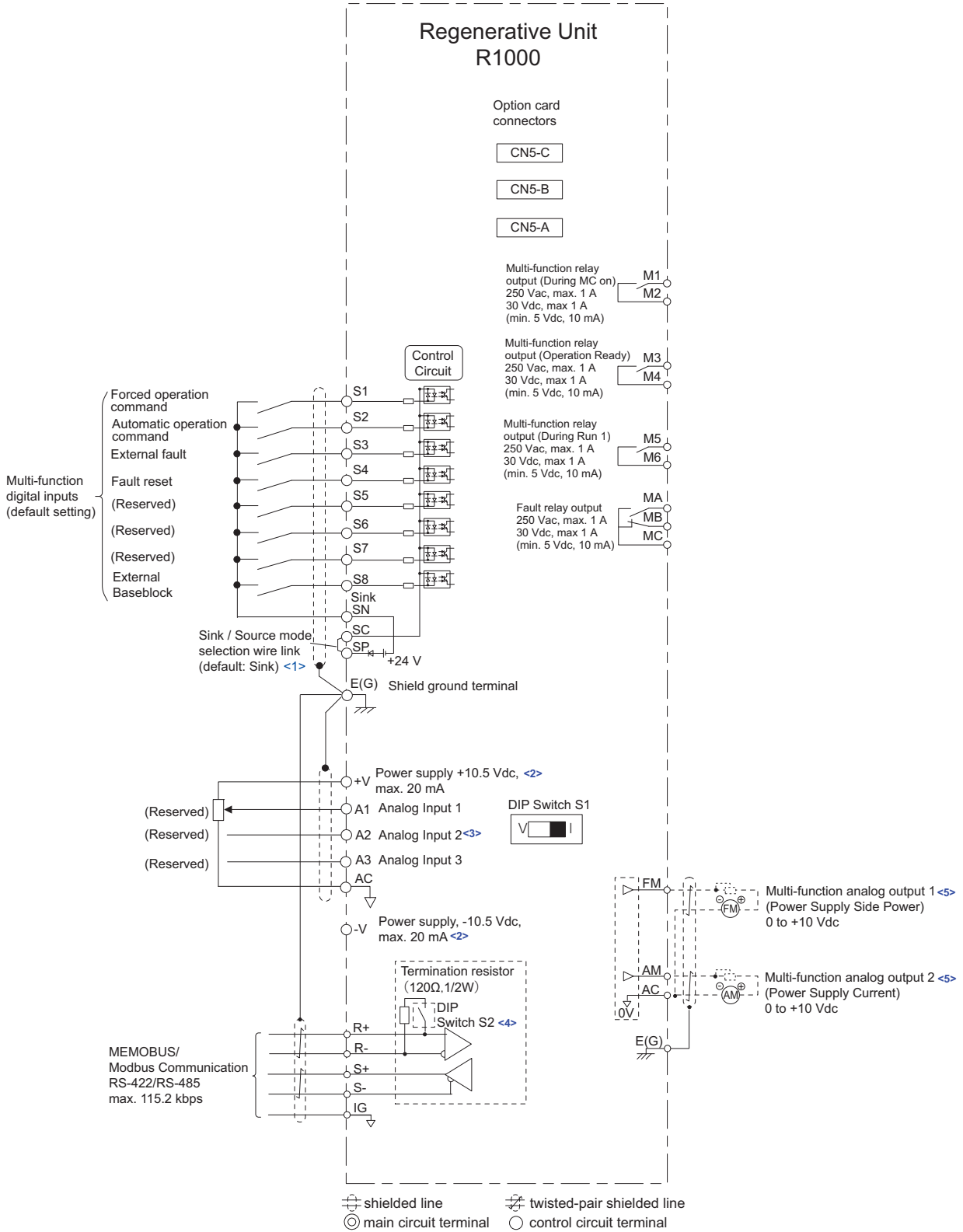

Figure 3.20 Control Circuit Wiring

- <1> The default setting is for Sinking Mode. Control is possible with no-voltage contacts or NPN transistors. For details, refer to [Use the wire jumper between terminals SC and SP or SC and SN to select between Sink mode, Source mode or external power supply for the digital inputs S1 to S8 as shown in Table 3.11 \(Default: Sink mode, internal power supply\). on page 53.](#)
- <2> The maximum output current capacity for the +V and -V terminals on the control circuit is 20 mA. Never short terminals +V, -V, and AC, as it can cause erroneous operation or damage the regenerative unit.

- <3> Set DIP switch S1 to select between a voltage or current input signal to terminal A2. The default setting is for current input. For details, refer to [Terminal A2 Input Signal Selection on page 53](#).
- <4> Set DIP switch S2 to the ON position to enable the termination resistor in a MEMOBUS/Modbus network.
- <5> Monitor outputs work with devices such as analog frequency meters, ammeters, voltmeters, and wattmeters. They are not intended for use as a feedback-type signal.

## ◆ Control Circuit Terminal Block Functions

Parameters determine which functions apply to the multi-function digital inputs (S1 to S8), multi-function relay outputs (M1, M2, M3, M4, M5, M6), and multi-function analog monitor outputs (FM, AM). The default setting is listed next to each terminal name in [Table 3.6](#).

**NOTICE:** Install an MC on the power supply side of the regenerative unit when the drive should not automatically restart after power loss. To get the full performance life out of the electrolytic capacitors and circuit relays, refrain from switching the power supply off and on more than once every 30 minutes. Frequent use can damage the regenerative unit.

### ■ Input Terminals

[Table 3.6](#) lists the input terminals on the regenerative unit. Text in parenthesis indicates the default setting for each multi-function input.

**Table 3.6 Control Circuit Input Terminals**

Type	No.	Terminal Name (Function)	Function (Signal Level) Default Setting	Page
Multi-Function Digital Inputs	S1	Multi-function input 1 (Forced operation command)	<ul style="list-style-type: none"> <li>Photocoupler</li> <li>24 Vdc, 8 mA</li> <li>Set the S3 jumper to select between sinking, sourcing mode, and the power supply. Refer to <a href="#">Use the wire jumper between terminals SC and SP or SC and SN to select between Sink mode, Source mode or external power supply for the digital inputs S1 to S8 as shown in Table 3.11 (Default: Sink mode, internal power supply). on page 53.</a></li> </ul>	145
	S2	Multi-function input 2 (Automatic operation command)		
	S3	Multi-function input 3 (External fault)		
	S4	Multi-function input 4 (Fault reset)		
	S5	Multi-function input 5 (Reserved)		
	S6	Multi-function input 6 (Reserved)		
	S7	Multi-function input 7 (Reserved)		
	S8	Multi-function input 8 (External Baseblock)		
	SC	Multi-function input common		
	SP	Digital input power supply +24 Vdc		
	SN	Digital input power supply 0 V	<b>NOTICE:</b> Do not jumper or short terminals SP and SN. Failure to comply will damage the regenerative unit.	
Analog Inputs	+V	Analog reference input	10.5 Vdc (max allowable current 20 mA)	–
	-V	Analog reference input	-10.5 Vdc (max allowable current 20 mA)	–
	A1	Multi-function analog input 1 (Reserved)	-10 to 10 Vdc, 0 to 10 Vdc (input impedance: 20 kΩ)	147
	A2	Multi-function analog input 2 (Reserved)	<ul style="list-style-type: none"> <li>-10 to 10 Vdc, 0 to 10 Vdc (input impedance: 20 kΩ)</li> <li>4 to 20 mA, 0 to 20 mA (input impedance: 250 Ω)</li> <li>Voltage or current input must be selected by DIP switch S1 and H3-09.</li> </ul>	148
	A3	Multi-function analog input 3 (Reserved)	<ul style="list-style-type: none"> <li>-10 to 10 Vdc, 0 to 10 Vdc (input impedance: 20 kΩ)</li> <li>Use DIP switch S4 on the terminal board to select between analog and PTC input.</li> </ul>	147
	AC	Frequency reference common	0 V	–
	E (G)	Ground for shielded lines and option cards	–	–

### 3.9 Control Circuit Wiring

#### ■ Output Terminals

Table 3.7 lists the output terminals on the regenerative unit. Text in parenthesis indicates the default setting for each multi-function output.

Table 3.7 Control Circuit Output Terminals

Type	No.	Terminal Name (Function)	Function (Signal Level) Default Setting	Page
Fault Relay Output	MA	N.O. output (Fault)	30 Vdc, 10 mA to 1 A; 250 Vac, 10 mA to 1 A Minimum load: 5 Vdc, 10 mA	146
	MB	N.C. output (Fault)		
	MC	Fault output common		
Multi-Function Relay Output <>	M1	Multi-function relay output (During MC on)	30 Vdc, 10 mA to 1 A; 250 Vac, 10 mA to 1 A Minimum load: 5 Vdc, 10 mA	146
	M2			
	M3	Multi-function relay output (Operation Ready)	30 Vdc, 10 mA to 1 A; 250 Vac, 10 mA to 1 A Minimum load: 5 Vdc, 10 mA	
	M4			
	M5	Multi-function relay output (During Run 1)		
	M6			
Monitor Output	FM	Analog monitor output 1 (Power Supply Side Power)	-10 to +10 Vdc, or 0 to +10 Vdc	148
	AM	Analog monitor output 2 (Power Supply Side Current)		
	AC	Monitor common		

<1> Refrain from assigning functions to digital relay outputs that involve frequent switching, as doing so may shorten relay performance life. Switching life is estimated at 200,000 times (assumes 1 A, resistive load).

#### ■ Serial Communication Terminals

Table 3.8 Control Circuit Terminals: Serial Communications

Type	No.	Signal Name	Function (Signal Level)		Page
MEMOBUS/Modbus Communication <>	R+	Communications input (+)	MEMOBUS/Modbus communication: Use an RS-422 or RS-485 cable to connect the regenerative unit.	RS-422/RS-485 MEMOBUS/Modbus communication protocol 115.2 kbps (maximum)	162
	R-	Communications input (-)			
	S+	Communications output (+)			
	S-	Communications output (-)			
	IG	Shield ground			

<1> Enable the termination resistor in the last regenerative unit in a MEMOBUS/Modbus network by setting DIP switch S2 to the ON position.

#### ◆ Terminal Configuration

The control circuit terminals are arranged as shown in Figure 3.21.

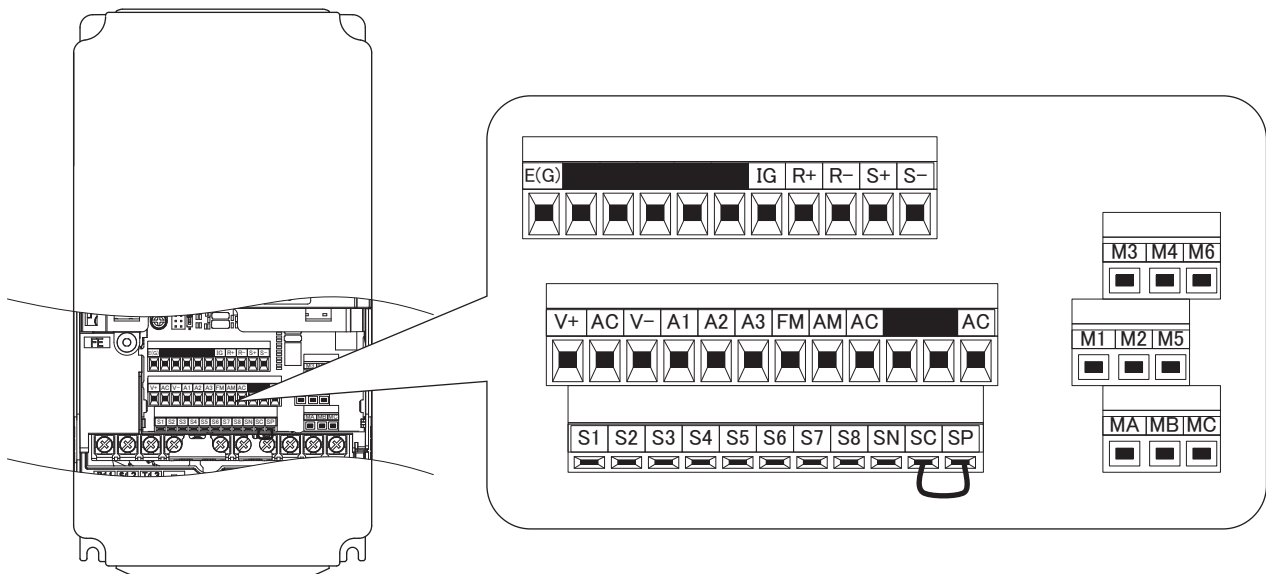

Figure 3.21 Control Circuit Terminal Arrangement

## ■ Wire Size and Torque Specifications

Select appropriate wire type and gauges from [Table 3.9](#).

For simpler and more reliable wiring, use crimp ferrules on the wire ends. Refer to [Table 3.10](#) for ferrule terminal types and sizes.

**Table 3.9 Wire Gauge and Torque Specifications**

Terminal	Screw Size	Tightening Torque N·m (lb·in.)	Bare Wire Terminal		Ferrule-Type Terminal		Wire Type
			Recomm. Gauge mm <sup>2</sup> (AWG)	Applicable Gauge mm <sup>2</sup> (AWG)	Recomm. Gauge mm <sup>2</sup> (AWG)	Applicable Gauge mm <sup>2</sup> (AWG)	
FM, AC, AM, SC, SP, SN, A1, A2, A3, +V, -V, S1 to S8, MA, MB, MC, M1 to M6	M3.5	0.8 to 1.0 (7.1 to 8.6)	0.75 (18)	0.5 to 2 (20 to 14)	—	—	Shielded wire, etc.
E (G)	M3.5	0.8 to 1.0 (7.1 to 8.6)	1.25 (12)	0.5 to 2 (20 to 14)	—	—	
IG, R+, R-, S+, S-	M2	0.22 to 0.25 (1.9 to 2.2)	0.75 (18)	Stranded wire: 0.25 to 1.0 (24 to 17) Solid wire: 0.25 to 1.5 (24 to 16)	0.5 (20)	0.25 to 0.5 (24 to 20)	

## ■ Ferrule-Type Wire Terminals

Yaskawa recommends using CRIMPFOX 6, a crimping tool manufactured by PHOENIX CONTACT, to prepare wire ends with insulated sleeves before connecting to the regenerative unit. See [Table 3.10](#) for dimensions.

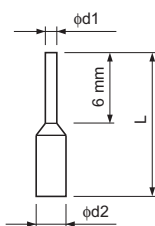

**Figure 3.22 Ferrule Dimensions**

**Table 3.10 Ferrule Terminal Types and Sizes**

Size mm <sup>2</sup> (AWG)	Type	L (mm)	d1 (mm)	d2 (mm)	Manufacturer
0.25 (24)	AI 0.25-6YE	10.5	0.8	2	PHOENIX CONTACT
0.34 (22)	AI 0.34-6TQ	10.5	0.8	2	
0.5 (20)	AI 0.5-6WH	14	1.1	2.5	

## ◆ Wiring the Control Circuit Terminal

This section describes the proper procedures and preparations for wiring the control terminals.

**WARNING!** *Electrical Shock Hazard. Do not remove covers or touch the circuit boards while the power is on. Failure to comply could result in death or serious injury.*

**NOTICE:** *Separate control circuit wiring from main circuit wiring (terminals R/L1, S/L2, T/L3, r1/l11,  $\sphericalangle$ 1/l21, t1/l31,  $\ominus$ ,  $\oplus$ ) and other high-power lines. Improper wiring practices could result in regenerative unit malfunction due to electrical interference.*

**NOTICE:** *Separate wiring for digital output terminals MA, MB, MC, M1 to M6 from wiring to other control circuit lines. Improper wiring practices could result in regenerative unit or equipment malfunction or nuisance trips.*

**NOTICE:** *Use a class 2 power supply (UL standard) when connecting to the control terminals. Improper application of peripheral devices could result in regenerative unit performance degradation due to improper power supply.*

**NOTICE:** *Insulate shields with tape or shrink tubing to prevent contact with other signal lines and equipment. Improper wiring practices could result in regenerative unit or equipment malfunction due to short circuit.*

**NOTICE:** *Connect the shield of shielded cable to the appropriate ground terminal. Improper equipment grounding could result in regenerative unit or equipment malfunction or nuisance trips.*



### 3.9 Control Circuit Wiring

Wire the control circuit only after terminals have been properly grounded and main circuit wiring is complete. Prepare the ends of the control circuit wiring as shown in [Figure 3.23](#). Refer to [Figure 3.25](#) for the treatment of the ends of the shield wire.

**NOTICE:** Use shielded twisted-pair cables as indicated to prevent operating faults. Failure to comply may cause electrical interference resulting in poor system performance due to improper wiring practices. Use shielded, twisted-pair cables and ground the shield to the shield ground terminal E (G) of the regenerative unit.

Connect control wires as shown in [Figure 3.23](#).

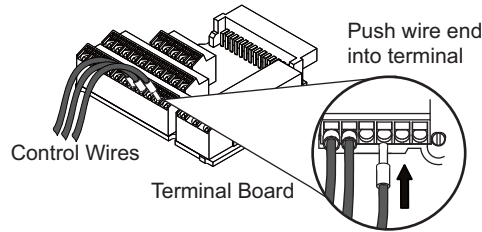

**Figure 3.23 Terminal Board Wiring Guide**

To disconnect control wires from the terminals use the procedure described in [Figure 3.24](#). Grasp the wire where it enters the terminal with a pair of pliers, then use a straight-edge screwdriver to release the terminal and pull the wire out. If it fits tightly, e.g. if ferrules are used, turn the wire for about 45° and then pull it gently out. Use this procedure to remove the wire jumper between terminals HC, H1 and H2 that is preinstalled at shipping.

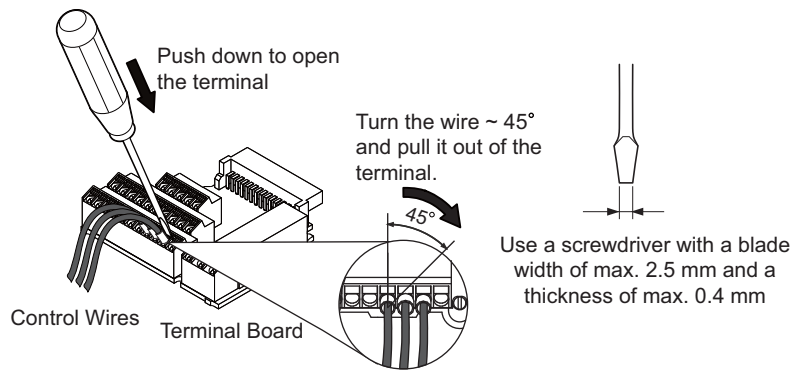

**Figure 3.24 Removing Wires from the Terminal Board**

For the control circuit wires, use shielded twisted-pair wires that have been prepared as shown in [Figure 3.25](#).

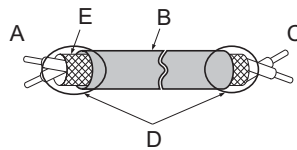

- |                                   |   |
|-----------------------------------|---|
| <b>A – Regenerative unit side</b> | <b>D – Shield sheath (insulate with tape)</b> |
| <b>B – Insulation</b>             | <b>E – Shield</b>                             |
| <b>C – Control device side</b>    |   |

**Figure 3.25 Preparing the Ends of Shielded Cables**

**NOTICE:** The analog signal wiring between the regenerative unit and the operator station or peripheral equipment should not exceed 50 meters when using an analog signal from a remote source. Failure to comply could result in poor system performance.



### 3.10 Control I/O Connections

Use the wire jumper between terminals SC and SP or SC and SN to select between Sink mode, Source mode or external power supply for the digital inputs S1 to S8 as shown in **Table 3.11** (Default: Sink mode, internal power supply).

**Note:** Never short terminals SP and SN as doing so will damage the regenerative unit.

**Table 3.11 Digital Input Sink / Source / External Power Supply Selection**

	Regenerative Unit Internal Power Supply (Terminal SN and SP)	External 24 Vdc Power Supply
Sinking Mode (NPN)		
Sourcing Mode (PNP)		

#### ◆ Terminal A2 Input Signal Selection

Terminal A2 can be used to input either a voltage or a current signal. Select the signal type using switch S1 as explained in **Table 3.12**. Set parameter H3-09 accordingly as shown in **Table 3.13**. Refer to **Figure 3.26** for locating switch S1.

To set the DIP switch, use tweezers or a tool with a tip width of approximately 0.8 mm.

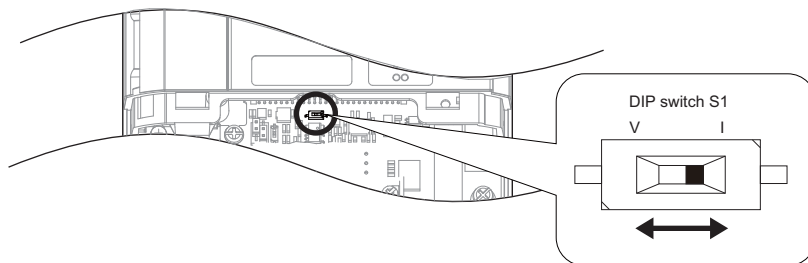

**Figure 3.26 DIP Switch S1**

**Table 3.12 DIP Switch S1 Settings**

Setting	Description
V (left position)	Voltage input (-10 to +10 V or 0 to 10 V)
I (right position)	Current input (4 to 20 mA or 0 to 20 mA): default setting

Table 3.13 Parameter H3-09 Details

No.	Parameter Name	Description	Setting Range	Default Setting
H3-09	Terminal A2 signal level selection	Selects the signal level for terminal A2. 0: 0 to 10 Vdc 1: -10 to 10 Vdc 2: 4 to 20 mA 3: 0 to 20 mA	0 to 3	2

◆ Using the Contact Outputs

Figure 3.27 illustrates the use of multi-function relay outputs and the fault relay outputs.

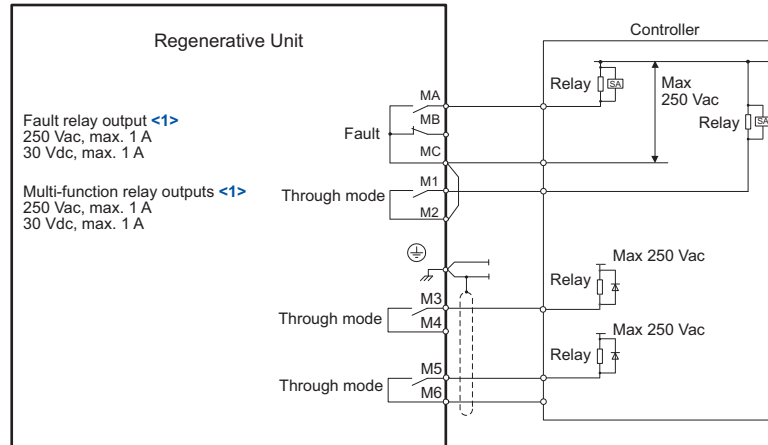

<1> Minimum load: 5 Vdc, 10 mA

Figure 3.27 Contact Outputs

◆ Connect to a PC

This regenerative unit is equipped with a USB port (type-B). The regenerative unit can connect to a USB port on a PC using a USB 2.0, AB-type cable (sold separately). After connecting the regenerative unit to a PC, Yaskawa DriveWizard Plus software can be used to monitor regenerative unit performance and manage parameter settings. Contact Yaskawa for more information on DriveWizard Plus.

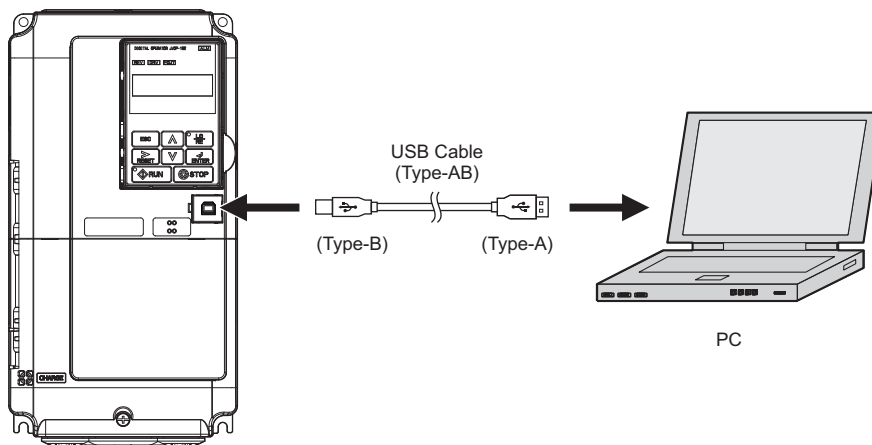

Figure 3.28 Connecting to a PC (USB)

## 3.11 Wiring Checklist

<input checked="" type="checkbox"/>	No.	Item	Page
<b>Regenerative Unit, Peripherals, Option Cards</b>			
<input type="checkbox"/>	1	Check regenerative unit model number to ensure receipt of correct model.	17
<input type="checkbox"/>	2	Make sure you have the correct peripheral devices.	–
<input type="checkbox"/>	3	Check the option card model number.	–
<b>Installation Area and Physical Setup</b>			
<input type="checkbox"/>	4	Ensure that the area surrounding the regenerative unit complies with specifications.	21
<b>Power Supply Voltage, Output Voltage</b>			
<input type="checkbox"/>	5	The voltage from the power supply should be within the input voltage specification range of the regenerative unit.	–
<input type="checkbox"/>	6	The total load must be within the output specifications of the regenerative unit.	17
<input type="checkbox"/>	7	A power supply with a capacity (kVA) that is larger than the rated input capacity of the regenerative unit must be used.	–
<input type="checkbox"/>	8	The ratings must be correct.	17
<b>Main Circuit Wiring</b>			
<input type="checkbox"/>	9	Confirm proper branch circuit protection as specified by national and local codes.	–
<input type="checkbox"/>	10	Properly wire the regenerative unit.	35
<input type="checkbox"/>	11	Suitable wires must be used to wire the power supply and regenerative unit.	43
<input type="checkbox"/>	12	Properly ground the regenerative unit. Review page 46.	46
<input type="checkbox"/>	13	Tighten control circuit and grounding terminal screws. Refer to <i>Wire Gauges and Tightening Torque on page 43</i>	43
<b>Control Circuit Wiring</b>			
<input type="checkbox"/>	14	Use twisted-pair line for all regenerative unit control circuit wiring.	51
<input type="checkbox"/>	15	Ground the shields of shielded wiring to the GND $\oplus$ terminal.	33
<input type="checkbox"/>	16	Properly wire any option cards.	–
<input type="checkbox"/>	17	Check for any other wiring mistakes. Only use a multimeter to check wiring.	–
<input type="checkbox"/>	18	Properly fasten regenerative unit control circuit terminal screws. Refer to <i>Wire Size and Torque Specifications on page 51</i> .	51
<input type="checkbox"/>	19	Pick up all wire clippings.	–
<input type="checkbox"/>	20	Ensure that no frayed wires on the terminal block are touching other terminals or connections.	–
<input type="checkbox"/>	21	Properly separate control circuit wiring and main circuit wiring.	–
<input type="checkbox"/>	22	The line between the input-side AC reactor and regenerative unit must be 10 m or shorter and the DC bus line between the regenerative unit and drive must be 5 m or shorter.	–



# Start-Up Programming & Operation

---

This chapter explains the functions of the digital operator and how to program the regenerative unit for initial operation.

<b>4.1</b>	<b>SECTION SAFETY</b> .....	<b>58</b>
<b>4.2</b>	<b>USING THE DIGITAL OPERATOR</b> .....	<b>59</b>
<b>4.3</b>	<b>THE DRIVE AND PROGRAMMING MODES</b> .....	<b>62</b>
<b>4.4</b>	<b>POWERING UP THE REGENERATIVE UNIT</b> .....	<b>65</b>
<b>4.5</b>	<b>OPERATION WITH THE DRIVE CONNECTED</b> .....	<b>66</b>
<b>4.6</b>	<b>VERIFYING PARAMETER SETTINGS AND BACKING UP CHANGES</b> .....	<b>69</b>
<b>4.7</b>	<b>TEST RUN CHECKLIST</b> .....	<b>71</b>

## 4.1 Section Safety

 **DANGER**

**Electrical Shock Hazard**

**Do not connect or disconnect wiring while the power is on.**

Failure to comply will result in death or serious injury.

 **WARNING**

**Electrical Shock Hazard**

**Do not operate equipment with covers removed.**

Failure to comply could result in death or serious injury.

The diagrams in this section may show units without covers or safety shields to show details. Be sure to reinstall covers or shields before operating the unit and run the unit according to the instructions described in this manual.

**Do not remove covers or touch circuit boards while the power is on.**

Failure to comply could result in death or serious injury.

## 4.2 Using the Digital Operator

Use the digital operator to enter Run and Stop commands, edit parameters, and display data including fault and alarm information.

### ◆ LCD Display

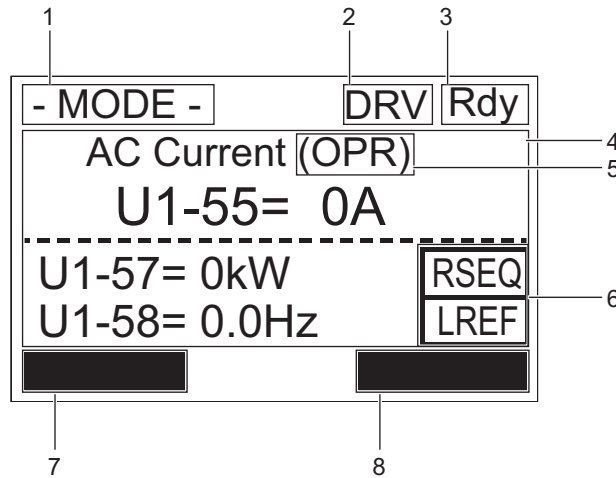









Figure 4.1 LCD Display

Table 4.1 Display and Contents

No.	Name	Display	Content
1	Operation Mode Menus	MODE	Displayed when in Mode Selection.
		MONITR	Displayed when in Monitor Mode.
		VERIFY	Indicates the Verify Menu.
		PRMSET	Displayed when in Parameter Setting Mode.
		SETUP	Displayed when in Setup Mode.
2	Mode Display Area	DRV	Displayed when in Drive Mode.
		PRG	Displayed when in Programming Mode.
3	Ready	Rdy	Indicates the regenerative unit is ready to run.
4	Data Display	-	Displays specific data and operation data.
5	DC Bus Voltage Feedback Reference Assignment <1>	OPR	Displayed when the DC bus voltage feedback Reference is assigned to the LCD Operator Option.
		AI	Displayed when the DC bus voltage feedback Reference is assigned to the Analog Input.
		COM	Displayed when the DC bus voltage feedback Reference is assigned to the MEMOBUS/Modbus Communication Inputs.
		OP	Displayed when the DC bus voltage feedback Reference is assigned to a Option regenerative unit.
6	LO/RE Display <2>	RSEQ	Displayed when the reference is supplied from a remote source.
		LSEQ	Displayed when the reference is supplied from the operator keypad.
		RREF	Displayed when the frequency reference is supplied from a remote source.
		LREF	Displayed when the frequency reference is supplied from the operator keypad.
7	Function Key 1 (F2)	HELP	Pressing  displays the Help menu.
		←	Pressing  scrolls the cursor to the left.
		HOME	Pressing  returns to the top menu (DC bus voltage feedback Reference).
		ESC	Pressing  returns to the previous display.
8	Function Key 2 (F1)	DATA	Pressing  scrolls to the next display.
		→	Pressing  scrolls the cursor to the right.
		RESET	Pressing  resets the existing regenerative unit fault or error.



<1> Displayed when in DC bus voltage feedback Reference Mode.

<2> Displayed when in DC bus voltage feedback Reference Mode and Monitor Mode.

## 4.2 Using the Digital Operator





### ◆ ALARM (ALM) LED Displays

Table 4.2 ALARM (ALM) LED Status and Contents

State	Content	Display
Illuminated	When the regenerative unit detects a fault.	
Flashing	<ul style="list-style-type: none"> <li>When an alarm occurs.</li> <li>When oPE is detected.</li> </ul>	
Off	Normal operation (no fault or alarm).	

### ◆ LO/RE LED and RUN LED Indications

Table 4.3 LO/RE LED and RUN LED Indications

LED	Lit	Flashing	Off
	When source of the Run command is assigned to the digital operator (LOCAL)	–	When a device other than the operator is selected for Run command control (REMOTE)
	During run	Stopped for an operation interlock. </>	During stop
Examples			

</> The indicator flashes in the following cases:

- When REMOTE operation is restored after inputting a Run command from an external terminal during LOCAL operation.
- A Run command was input from an external terminal in any mode other than Drive Mode.
- The STOP key on the digital operator was pressed during REMOTE operation.



◆ Menu Structure for Digital Operator

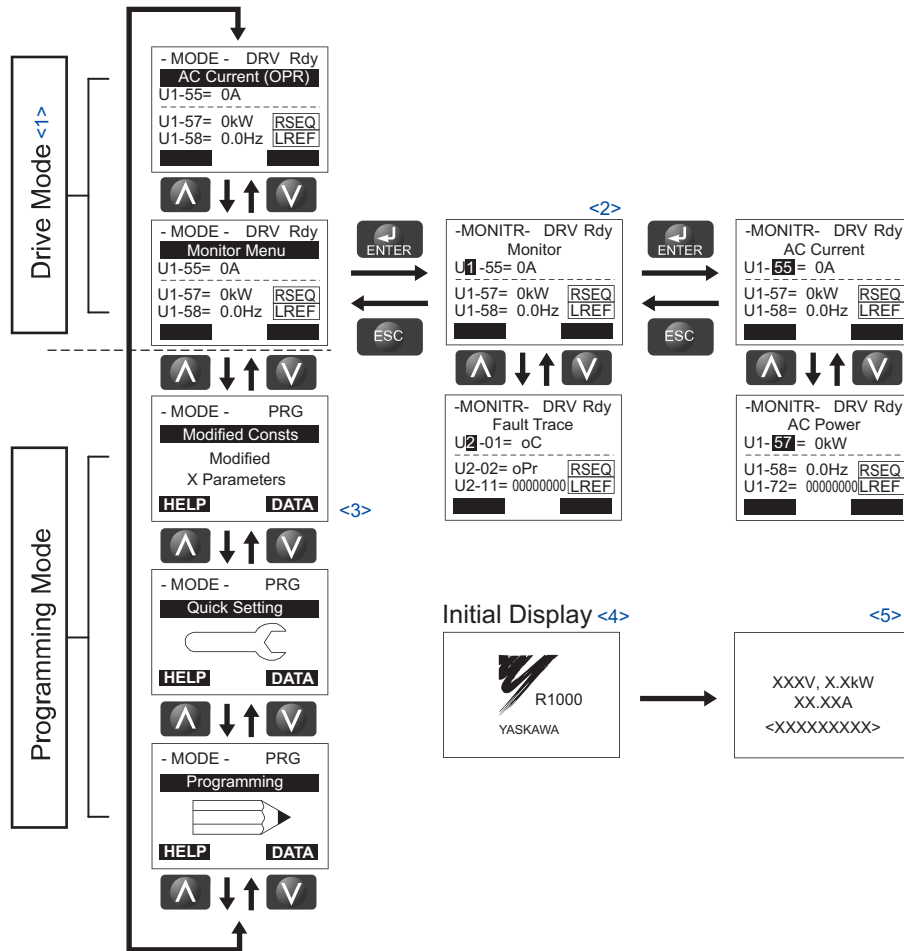

- <1> Pressing will start the regenerative unit operation.
- <2> Flashing characters are shown as **0**.
- <3> “X” characters are used as examples in this manual. The LCD Operator will display the actual setting values.
- <4> The DC bus voltage feedback reference appears after the initial display that shows the product name.
- <5> The information that appears on the display will vary depending on the regenerative unit.

Figure 4.2 Digital Operator Menu and Screen Structure

# 4.3 The Drive and Programming Modes

The regenerative unit has a Drive Mode and a Programming Mode.

**Drive Mode:** In Drive Mode the user can operate the regenerative unit, monitor operating status (DC bus voltage, DC current reference, etc.).

**Programming Mode:** In Programming Mode the user can edit and verify parameter settings. When the regenerative unit is in Programming Mode it will not accept a Run command unless b1-08 is set to 1.

### ◆ Navigating the Drive and Programming Modes (Default Setting)

**NOTICE:** Check the following items before you turn on the power supply.

- Is the power supply voltage correct?  
200 V Class: 200 to 240 Vac 50/60 Hz  
400 V Class: 380 to 480 Vac 50/60 Hz
- Are the regenerative unit and the control devices connected properly (e.g., is the phase order correct)?
- Is the phase order correct between the main circuit terminals (R/L1, S/L2, and T/L3) on the regenerative unit and the power supply voltage detection terminals (r1/l11, s1/l21, and t1/l31).
- Are the control circuit terminals on the regenerative unit connected properly to the control devices?
- Are the Run Commands for the regenerative unit and the control devices turned off?

The regenerative unit is set to operate in Drive Mode when it is first powered up. Switch between display screens by using the **▲** and **▼** keys.

#### ■ Drive Mode Details

The following actions are possible in the Drive Mode:

- Run and stop the regenerative unit
- Monitor the operation status of the regenerative unit (DC bus voltage feedback, Power Supply Side Voltage, Power supply side current, etc.)
- View information on an alarm
- View a history of alarms that have occurred

**Note:** The regenerative unit must be in Drive Mode to operate. Change to another mode when the regenerative unit is stopped.

#### ■ Programming Mode Details

The following actions are possible in the Programming Mode:

- **Verify Mode:** View a list of parameters that have been changed from the default values.
- **Setup Mode:** Access a list of commonly used parameters to simplify setup. Refer to [Setup Group Parameters on page 62](#).
- **Parameter Setting Mode:** Access and edit all parameter settings.

#### Setup Group Parameters

Parameters most likely to be changed are assigned to the group of User Parameters, A2-01 through A2-32. User Parameters are part of the Setup Group, which provides quicker access by eliminating the need to scroll through multiple menus.

**Table 4.4** lists the default settings of the A2-□□ parameters.











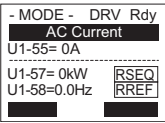

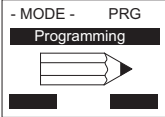

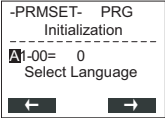

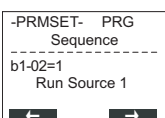
**Note:** Parameter b1-02 is displayed in Setup Mode regardless of A2-□□ parameter settings.

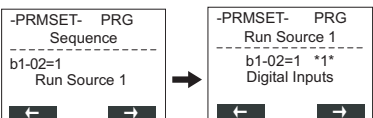
**Table 4.4 Setup Group Parameters**

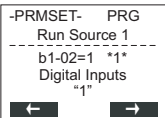
A2-□□	Default	Name
A2-01	b1-02	Run Command Selection 1
A2-02	b1-21	Operator Operation Mode

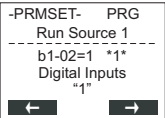
◆ Changing Parameter Settings or Values

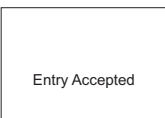
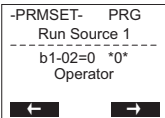
This example explains changing b1-02 (Run Command Selection) from 01 to 00.

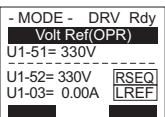
	Step		Display/Result
1.	Turn on the power to the regenerative unit. The initial display appears.	→	
2.	Press the  or  key until the Parameter Setting Mode screen appears.	→	
3.	Press the  key to enter the parameter menu tree.	→	
4.	Press  or  key to select the B parameter group.	→	
5.	Press  two times.	→	
6.	Press  to view the current setting value (1). "1" Flashes.	→	
7.	Press the  key and enter 0.	→	
8.	Press  and the regenerative unit will confirm the change.	→	
9.	The display automatically returns to the screen shown in Step 4.	→	
10.	Press the  key until back at the initial display.	→	

## 4.3 The Drive and Programming Modes

### ◆ Verifying Parameter Changes: Verify Mode

The Verify Mode lists edited parameters from the Programming Mode. The Verify Mode helps determine which settings have been changed, and is particularly useful when replacing a regenerative unit. If no settings have been changed, the Verify Mode will read “None”. The Verify Mode also allows users to quickly access and re-edit any parameter settings that have been changed.

Note: A1-□□, and A2-01 to A2-32 are not displayed even when those parameters have been changed from their default values.

Step		Display/Result
1.	Turn on the power to the regenerative unit. The initial display appears.	
2.	Press  or  until the display shows the top of the Verify Menu.	
3.	Press  to enter the list of parameters that have been edited from their original default settings. If parameters other than b1-02 have been changed, use the  or  key to scroll until b1-02 appears.	
4.	Press the  key to access the setting value.	

### ◆ Switching Between LOCAL and REMOTE

LOCAL mode is when the regenerative unit is set to accept the Run command from the digital operator RUN key. REMOTE mode is when the regenerative unit is set to accept the Run command from an external device.

Switch the operation between LOCAL and REMOTE using the key on the digital operator or via a digital input.

- Note:**
1. After selecting LOCAL, the LO/RE light will remain lit.
  2. The regenerative unit will not allow the user to switch between LOCAL and REMOTE during run.

#### ■ Using the LO/RE Key on the Digital Operator

Step		Display/Result
1.	Turn on the power to the regenerative unit. The initial display appears.	
2.	Press . The LO/RE light will light up. The regenerative unit is now in LOCAL. To set the regenerative unit for REMOTE operation, press the key again.	

#### ■ Using Input Terminals S1 through S8 to Switch between LOCAL and REMOTE

It is possible to switch between LOCAL and REMOTE modes using one of the digital input terminals S1 through S8 (set the corresponding parameter H1-□□ to “1”).

Setting H1-□□ to 1 disables the LO/RE key on the digital operator.

## 4.4 Powering Up the Regenerative Unit

### ◆ Powering Up the Regenerative Unit and Operation Status Display

#### ■ Powering Up the Regenerative Unit

Review the following checklist before turning the power on.

**NOTICE: Equipment Damage.** Check the following items before applying power to the unit. Failure to comply could result in damage to the regenerative unit.

Item to Check	Description
<b>Power supply voltage</b>	Check the power supply voltage. 200 V class: Three-phase 200 to 240 Vac 50/60 Hz 400 V class: Three-phase 380 to 480 Vac 50/60 Hz
	Properly wire the power supply input terminals (R/L1, S/L2, and T/L3).
	Properly wire the phase order of the power supply input terminals (R/L1, S/L2, and T/L3) and the power supply voltage detection terminals (r1/l11, s1/l21, and t1/l31).
	Check for proper grounding of regenerative unit.
<b>Regenerative unit output terminals and drive terminals</b>	Properly connect the DC voltage output terminals (⊕/⊖) on the regenerative unit to the DC power supply input terminals (⊕/⊖) on the drive. Be particularly careful to correctly connect the ⊕ and ⊖ terminals.
<b>Control circuit terminals</b>	Properly connect the control circuit terminals on the regenerative unit to other control devices.
<b>Regenerative unit control terminal status</b>	Turn off the Run Commands for the regenerative unit and the peripheral control devices.
<b>Power coordinating reactor, current suppression reactor, and fuse connections to regenerative unit</b>	Properly connect the Power coordinating reactor, current suppression reactor, and fuse to regenerative unit as shown in the Standard Connection Diagram.

#### ■ Status Display

When the power supply to the regenerative unit is turned on, the digital operator lights will appear as follows:

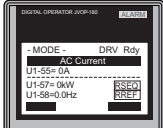
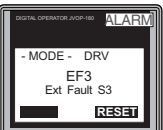
Status	Name	Description
<b>Normal Operation</b>		The data display area displays the DC bus voltage feedback reference. <b>DRV</b> is lit.
<b>Fault</b>	 <p>Example: External Fault</p>	Data displayed varies by the type of fault. Refer to <a href="#">Troubleshooting on page 73</a> for more information. <b>DRV</b> and <b>ALM</b> are lit.

## 4.5 Operation with the Drive Connected

### ◆ Drive Connection Example

Refer to *Standard Connection Diagram on page 32* for details.

### ◆ Timing Chart for Turning the Power Supply On and Off

*Figure 4.3* is a timing chart for turning the power supply on and off.

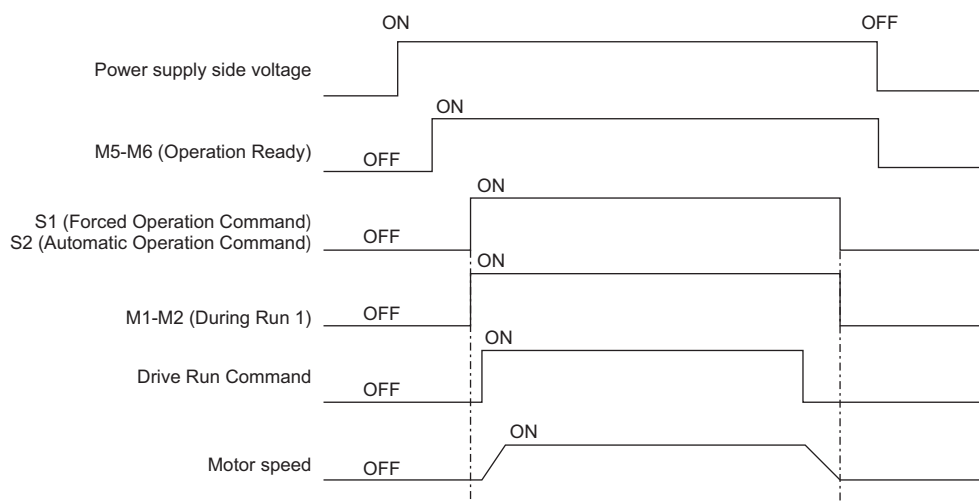

**Figure 4.3 Timing Chart for Power ON and Run Command Sequence**

Observe the following precautions when you perform operation with the regenerative unit connected to the drive.

- After turning on the power supply to the regenerative unit, wait for the Operation Ready signal on the multi-function contact output to turn on and then input the Run Command for the regenerative unit.
- Confirm that the regenerative unit is operating (i.e., confirm that During Run 1 is on) and then turn on the Run Command for the drive.
- To stop the regenerative unit, turn off the Run Command to the drive, confirm that the motor has stopped, and then input the Stop Command.
- Wait for the regenerative unit to stop and the During Run 1 multi-function contact output to turn off, then turn off the power supply.

### ◆ Operation Command Selection

The automatic operation command and forced operation command are available in the regenerative unit.

Select one of the operation commands according to the application.

**Note:** Select forced operation command when the motor vibrates during automatic operation.

### ■ Automatic Operation Command

When the multifunction input terminal S2 (H1-02 = 3D (default setting)) is “closed”, the regenerative unit detects any increase/decrease of the bus voltage and performs an automatic run/stop.

The regenerative unit stops after the minimum operation time set to C7-16 has passed when the bus voltage is less than the acceptable voltage set to the operation start/stop level.

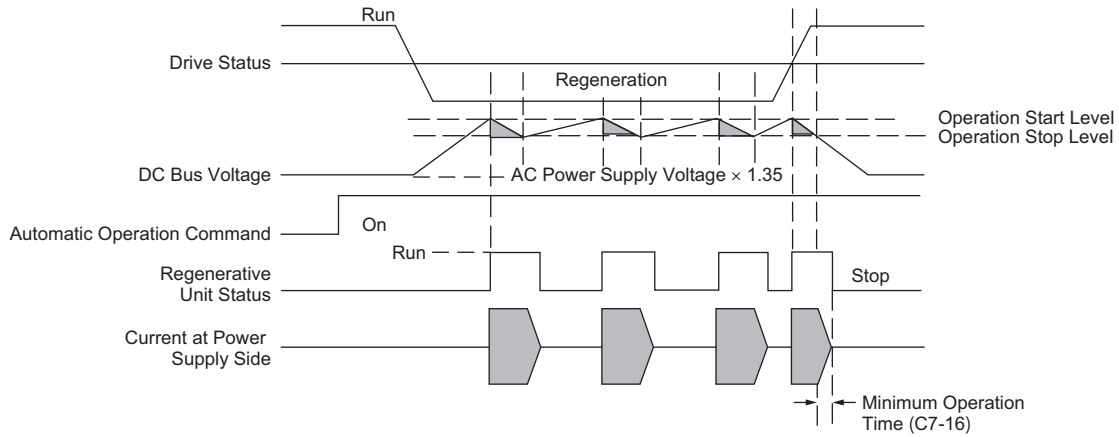

Figure 4.4 Automatic Operation Command Time Chart

### ■ Forced Operation Command

When the multi-function input terminal S1 (H1-01 = 3C (default setting)) is “closed”, the regenerative unit starts operation. When the terminal S1 is “open”, the regenerative unit stops operation after the minimum operation time has passed.

**Note:** When forced operation command is selected, use a sequence so that the operation commands of the regenerative unit and the drive are input at the same time.

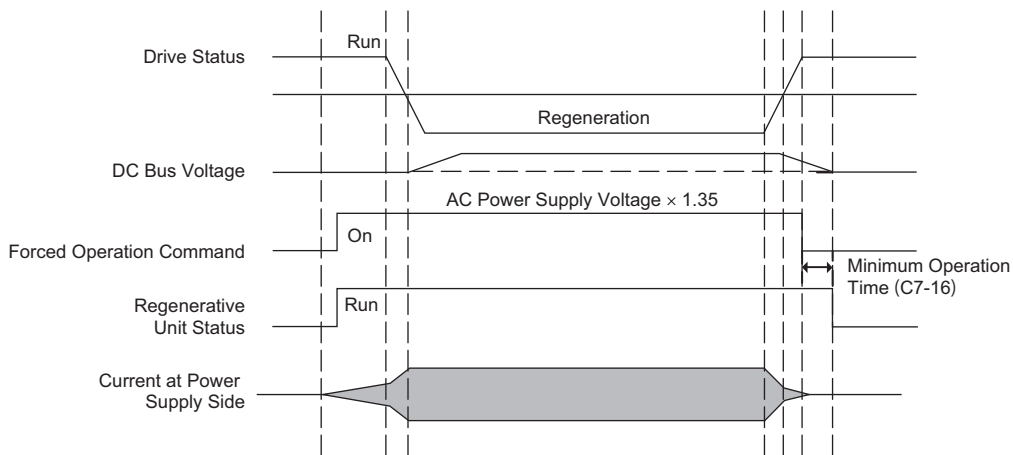

Figure 4.5 Forced Operation Command Time Chart

### ◆ Interlocks

#### ■ Stopping the Regenerative Unit for Faults in Peripheral Devices

If an external device fails or a fault occurs, the fault contact output on the regenerative unit is activated to stop operation. To use an external fault, set H1-□□ (terminal S1 to S8 function selection) to one of the values from [Table 4.5](#).

When an external fault is input, EF□ is displayed on the digital operator.

The □ in EF□ is the number of the terminal where the external fault signal was input.

Example: If an external fault signal is input to the S3 terminal, EF3 is displayed.

Select the number to set for H1-□□ according to the combination of the following three conditions:

- Use an input contact for a signal from the peripheral device.
- Use detection of an external fault.
- Stop operation (as the operation selection when an external fault is detected).

[Table 4.5](#) shows the relationship between the combination of conditions and the set value of H1-□□.

**Table 4.5 Combination of Conditions**

Setting Value	Input Contact <1>		Detection <2>		Operation Selection	
	N.O. Contact	N.C. Contact	Always Detect	Detect Only during Operation	Stop Unit (Fault)	Continue Operation (Minor Fault)
24	○	–	○	–	○	–
25	–	○	○	–	○	–
26	○	–	–	○	○	–
27	–	○	–	○	○	–
2C	○	–	○	–	–	○
2D	–	○	○	–	–	○
2E	○	–	–	○	–	○
2F	–	○	–	○	–	○

<1> When using an input contact, set whether to detect a fault when the signal opens or closes. (N.O.: External fault when closed, N.C.: External fault when open)

<2> When using detection of a fault, set whether to always detect faults or to detect them only during operation.



## 4.6 Verifying Parameter Settings and Backing Up Changes

Use the Verify Mode to check all changes to parameter settings. Refer to *Verifying Parameter Changes: Verify Mode on page 64*.

Save the verified parameter settings. Change the access level or set a password to the regenerative unit to prevent accidental modification of parameter settings.

### ◆ Backing Up Parameter Values: o2-03

Setting o2-03 to 1 saves all parameter settings to the regenerative unit internal memory. The regenerative unit can now recall all the saved parameters by performing a User Initialization (A1-03 = 1110).

No.	Parameter Name	Description	Setting Range	Default Setting
o2-03	User Defaults	Lets the user create a set of default settings for a User Initialization. 0: Saved/Not Set 1: Set Defaults - Saves current parameter settings as the default values for a User Initialization. 2: Clear All - Clears the currently saved user settings. After saving the user parameter set value, the items of 1110 (User Initialization) are displayed in A1-03 (User Parameter Default Value).	0 to 2	0
A1-03	Initialize Parameters	Selects a method to initialize the parameters. 0: No Initialize 1110: User Initialization (The user must first program and store desired settings using parameter o2-03) 2220: 2-Wire Initialization (parameter initialized prior to shipment) 5550: oPE4 Fault reset	0, 0110, 2220, 5550	0

### ◆ Parameter Access Level: A1-01

Setting the Access Level for “Operation only” (A1-01 = 0) allows the user to access parameters A1-□□ and U□-□□ only.

Other parameters are not displayed.

Setting the Access Level for “User Parameters” (A1-01 = 1) allows the user to access only the parameters that have been previously saved as User Parameters. This is helpful when displaying only the relevant parameters for a specific application.



No.	Parameter Name	Description	Setting Range	Default Setting
A1-01	Access Level Selection	Selects which parameters are accessible via the digital operator. 0: Operation only. A1-01, A1-04, and A1-06 can be set and monitored, and U□-□□ parameters can also be viewed. 1: User Parameters. Only recently changed parameters from application parameters A2-01 to A2-16 and A2-17 to A2-32 can be set and monitored. 2: Advanced Access Level. All parameters can be set and monitored.	0 to 2	2
A2-01 to A2-32	User Parameters 1 to 32	Parameters selected by the user are saved as User Parameters, including recently viewed parameters and parameters specifically selected for quick access. If parameter A2-33 is set to 1, recently viewed parameters will be listed between A2-17 and A2-32. Parameters A2-01 through A2-16 must be manually selected by the user. If A2-33 is set to 0, recently viewed parameters will not be saved to the group of User Parameters. A2-□□ parameters are now available for manual programming.	A1-00 to o4-19	—

## 4.6 Verifying Parameter Settings and Backing Up Changes

No.	Parameter Name	Description	Setting Range	Default Setting
A2-33	User Parameter Automatic Selection	0: Parameters A2-01 through A2-32 are reserved for the user to create a group of User Parameters. 1: Save history of recently viewed parameters. Recently edited parameters will be saved to A2-17 through A2-32 for quick access. The most recently changed parameter is saved to A2-17. The second most recently changed parameter is saved to A2-18, etc.	0,1	0

### ◆ Password Settings: A1-04, A1-05

The user can set a password in parameter A1-05 to restrict access to the regenerative unit. The password must be entered to A1-04 to unlock parameter access (i.e., parameter setting A1-04 must match the value programmed into A1-05). The following parameters cannot be viewed or edited until the value entered to A1-04 correctly matches the value set to A1-05: A1-01, A1-03, and A2-01 through A2-33.

**Note:** Parameter A1-05 is hidden from view. To display A1-05, access parameter A1-04 and press  and  simultaneously.

### ◆ Copy Function

Parameter settings can be copied to another regenerative unit to simplify parameter restoration or multiple regenerative unit setup. The regenerative unit supports the following copy options:

#### • LCD Operator (standard in all models)

The LCD operator used to operate the regenerative unit supports copying, importing, and verifying parameter settings. Refer to [o3: Copy Function on page 152](#) for details.

#### • LED Operator

The optional LED operator also supports copying, importing, and verifying parameter settings. Refer to the manual supplied with the LED operator for instructions.

#### • USB Copy Unit and CopyUnitManager

The copy unit is an external option connected to the regenerative unit to copy parameter settings from one regenerative unit and save those settings to another regenerative unit. Refer to the manual supplied with the USB Copy Unit for instructions.

**Note:** Connect the USB Copy Unit to the RS-422/RS-485 communication port on the regenerative unit.

CopyUnitManager is a PC software tool. It allows the user to load parameter settings from the Copy Unit onto a PC, or from the PC onto a Copy Unit. This is useful when managing parameters for various regenerative units or applications. Refer to the manual supplied with CopyUnitManager for instructions.

### ■ Copying Procedure for the LCD Operator

The LCD operator can perform the following operations by changing the o3-01(Copy Function Selection) parameter in the regenerative unit.

#### Read (o3-01 = 1)

Copies all parameters from the regenerative unit to the LCD operator.

**Note:** There is a limit to the number of read operations that you can perform from the LCD operator. As a guide, do not perform more than 100,000 read operations.

#### Copy (o3-01 = 2)



Copies all parameters from the LCD operator to the regenerative unit.

#### Verify (o3-01 = 3)

Compares the parameters in the regenerative unit with the parameter settings saved on the LCD operator for matches.

## 4.7 Test Run Checklist

Review the checklist before performing a test run. Check each item that applies.

<input checked="" type="checkbox"/>	No.	Checklist	Page
<input type="checkbox"/>	1	Thoroughly read the manual before performing a test run.	–
<input type="checkbox"/>	2	Check the <a href="#">Wiring Checklist on page 55</a> .	55
<input type="checkbox"/>	3	Set the correct power supply voltage.	65
<input type="checkbox"/>	4	Turn on the power supply to the regenerative unit and drive.	65
<input type="checkbox"/>	5	Correctly sequence the Run commands.	66
<input type="checkbox"/>	6	The <b>DRV</b> should light after giving a Run command.	–
<input type="checkbox"/>	7	To give Run command from the digital operator, press  key to set to LOCAL.	59, 64
<input type="checkbox"/>	8	To give Run command from the control circuit terminals, press the  to set REMOTE. (The LO/RE indicator is lit off while REMOTE is set.)	64



# Troubleshooting

---

This chapter provides descriptions of the regenerative unit faults, alarms, errors, related displays, and guidance for troubleshooting. This chapter can also serve as a reference guide for tuning the regenerative unit during a trial run.

<b>5.1</b>	<b>SECTION SAFETY</b> .....	<b>74</b>
<b>5.2</b>	<b>ALARMS, FAULTS, AND ERRORS</b> .....	<b>75</b>
<b>5.3</b>	<b>FAULT DETECTION</b> .....	<b>79</b>
<b>5.4</b>	<b>ALARM DETECTION</b> .....	<b>89</b>
<b>5.5</b>	<b>OPERATOR PROGRAMMING ERRORS</b> .....	<b>96</b>
<b>5.6</b>	<b>COPY FUNCTION RELATED DISPLAYS</b> .....	<b>98</b>
<b>5.7</b>	<b>DIAGNOSING AND RESETTING FAULTS</b> .....	<b>99</b>

## 5.1 Section Safety

### WARNING

#### Electrical Shock Hazard

**If a fuse is open or residual current monitoring/detection (RCM or RCD) is tripped, check the wiring and the selection of the peripheral devices.**

Contact your supplier if the cause cannot be identified. Failure to comply may result in electrical shock by indirect or direct contact. The regenerative unit can cause a residual current with a DC component in the protective earthing conductor.

**After blowing a fuse or residual current monitoring/detection (RCM or RCD) is tripped, do not attempt to restart the unit or operate peripheral devices until five minutes pass and CHARGE lamp is OFF.**

Failure to comply could result in death, serious injury, and damage to the unit.

**Do not connect or disconnect wiring while the power is on.**

Failure to comply could result in death or serious injury.

Before servicing, disconnect all power to the equipment. The internal capacitor remains charged even after the power supply is turned off. The charge indicator LED will extinguish when the DC bus voltage is below 50 Vdc. To prevent electric shock, wait for at least the time specified on the warning label; after all indicators are OFF, measure for unsafe voltages to confirm the unit is safe prior to servicing.

**Do not operate equipment with covers removed.**

Failure to comply could result in death or serious injury.

The diagrams in this section may illustrate units without covers or safety shields to display details. Be sure to reinstall covers or shields before operating the unit and run the unit according to the instructions described in this manual.

**Do not touch terminals before the capacitors have fully discharged.**

Failure to comply could result in death or serious injury.

Before servicing, disconnect all power to the equipment. The internal capacitor remains charged even after the power supply is turned off. The charge indicator LED will extinguish when the DC bus voltage is below 50 Vdc. To prevent electric shock, wait for at least the time specified on the warning label; after all indicators are OFF, measure for unsafe voltages to confirm the unit is safe prior to servicing.

**Do not allow unqualified personnel to perform work on the unit.**

Failure to comply could result in death or serious injury.

Installation, maintenance, inspection and servicing must be performed only by authorized personnel familiar with installation, adjustment and maintenance this equipment.

**Do not perform work on the unit while wearing loose clothing, jewelry, or without eye protection.**

Failure to comply could result in death or serious injury.

Remove all metal objects such as watches and rings, secure loose clothing and wear eye protection before beginning work on the unit.

**Do not remove covers or touch circuit boards while the power is on.**

Failure to comply could result in death or serious injury.

## 5.2 Alarms, Faults, and Errors

### ◆ Types of Alarms, Faults, and Errors

Check the digital operator for information about possible faults if the regenerative unit fails to operate.

If problems occur that are not covered in this manual, contact the nearest Yaskawa representative with the following information:

- Regenerative unit model
- Software version
- Date of purchase
- Description of the problem

**Table 5.1** contains descriptions of the various types of alarms, faults, and errors that may occur while operating the regenerative unit.

If the regenerative unit fails, contact your Yaskawa representative or the nearest Yaskawa sales office.

**Table 5.1 Types of Alarms, Faults, and Errors**

Type	Response
<b>Faults</b>	<p>When the regenerative unit detects a fault:</p> <ul style="list-style-type: none"> <li>• The digital operator displays text indicating the specific fault and the ALM indicator LED remains lit until the fault is reset.</li> <li>• The fault interrupts regenerative unit output.</li> <li>• Some faults allow the user to select the stopping method when the fault occurs.</li> <li>• Fault output terminals MA-MC will close, and MB-MC will open.</li> <li>• The regenerative unit will remain inoperable until the fault is cleared. Refer to <i>Fault Reset Methods on page 99</i>.</li> </ul>
<b>Minor Faults and Alarms</b>	<p>When the regenerative unit detects an alarm or a minor fault:</p> <ul style="list-style-type: none"> <li>• The digital operator displays text indicating the specific alarm or minor fault, and the ALM indicator LED flashes.</li> <li>• A multi-function contact output set to be tripped by a minor fault (H2-□□ = 10) closes. If the output is set to be tripped by an alarm, the contact will not close.</li> </ul> <p>Remove the cause of the problem to reset a minor fault or alarm.</p>
<b>Operation Errors</b>	<p>An operation error occurs when parameter settings conflict or do not match hardware settings (such as with an option card). When the regenerative unit detects an operation error:</p> <ul style="list-style-type: none"> <li>• The digital operator displays text indicating the specific error.</li> <li>• Multi-function contact outputs do not operate.</li> </ul> <p>The regenerative unit will not operate until the error has been reset. Correct the settings that caused the operation error to clear the error.</p>
<b>Copy Function Errors</b>	<p>Copy Function Errors occur when using the digital operator or the USB Copy Unit to copy, read, or verify parameter settings.</p> <ul style="list-style-type: none"> <li>• The digital operator displays text indicating the specific error.</li> <li>• Multi-function contact outputs do not operate.</li> </ul> <p>Pressing any key on the digital operator will clear the fault. Investigate the cause of the problem (such as model incompatibility) and try again.</p>

◆ Alarm and Error Displays

■ Faults

**Table 5.2** gives an overview of possible fault codes. Conditions such as overvoltages can trip faults and alarms. It is important to distinguish between faults and alarms to determine the proper corrective actions. When the regenerative unit detects a fault, the ALM indicator LED lights, the fault code appears on the digital operator, and the fault contact MA-MB-MC triggers. An alarm is present if the ALM LED blinks and the fault code on the digital operator flashes. Refer to *Minor Faults and Alarms on page 77* for a list of alarm codes.

**Table 5.2 Fault Displays**

Digital Operator Display		Name	Page	Digital Operator Display		Name	Page
LED	LCD			LED	LCD		
A <sub>ov</sub>	Aov	Power Supply Overvoltage	79	F <sub>rn</sub>	Fan	Internal Circulation Fan Fault	82
A <sub>uv</sub>	AUv	Power Supply Undervoltage	79	F <sub>dv</sub>	Fdv	Power Supply Frequency Fault	82
b <sub>us</sub>	bUS	Option Communication Error	79	F <sub>uA</sub>	FUA	AC Fuse Blowout	82
C <sub>E</sub>	CE	MEMOBUS/Modbus Communication Error	80	F <sub>uD</sub>	FUD	DC Fuse Blowout	83
C <sub>oF</sub>	CoF	Current Offset Fault	80	n <sub>SE</sub>	nSE	Node Setup Error	83
C <sub>PF00</sub> , C <sub>PF01</sub>	CPF00, CPF01	Control Circuit Error	80	o <sub>C</sub>	oC	Overcurrent	83
C <sub>PF02</sub>	CPF02	A/D Conversion Error	80	o <sub>FA00</sub> to o <sub>FA43</sub>	oFA00 to oFA43	Option Card Fault (CN5-A)	83
C <sub>PF03</sub>	CPF03	Control Board Connection Error	80	o <sub>Fb00</sub> to o <sub>Fb17</sub>	oFb00 to oFb17	Option Card Fault (CN5-B)	84
C <sub>PF06</sub>	CPF06	EEPROM Memory Data Error	81	o <sub>FC00</sub> to o <sub>FC55</sub>	oFC00 to oFC55	Option Card Fault (CN5-C)	85
C <sub>PF07</sub>	CPF07	Terminal Board Connection Error	81	o <sub>H</sub>	oH	Heatsink Overheat	86
C <sub>PF08</sub>	CPF08	Terminal Board Connection Error	81	o <sub>H1</sub>	oH1	Overheat 1	86
C <sub>PF11</sub> , C <sub>PF22</sub> <1>	CPF11 to CPF22	Control Circuit Error	80	o <sub>L2</sub>	oL2	Overload	86
C <sub>PF23</sub>	CPF23	Control Board Connection Error	81	o <sub>Pr</sub>	oPr	Operator Connection Fault	86
C <sub>PF24</sub>	CPF24	Unit Capacity Detect Fault	81	o <sub>v</sub>	ov	Overvoltage	86
C <sub>PF26</sub> to C <sub>PF35</sub> , C <sub>PF40</sub> to C <sub>PF45</sub>	CPF26 to CPF35, CPF40 to CPF45	Control Circuit Error	80	P <sub>F2</sub>	PF2	Input Power Supply Fault	87
E <sub>5</sub>	E5	MECHATROLINK Watchdog Timer Error	81	P <sub>F3</sub>	PF3	Input Phase Loss Detection	87
E <sub>F0</sub>	EF0	Option Card External Fault	81	S <sub>C</sub>	SC	IGBT Short Circuit or Ground Fault	87
E <sub>F1</sub> to E <sub>F8</sub>	EF1 to EF8	External Fault (input terminal S1 to S8)	81	S <sub>rC</sub>	SrC	Phase Order Fault	87
E <sub>rr</sub>	Err	EEPROM Write Error	82	U <sub>v1</sub>	Uv1	Main Circuit Undervoltage	87
				U <sub>v2</sub>	Uv2	Control Power Supply Undervoltage	88
				U <sub>v3</sub>	Uv3	Soft Charge Circuit Fault	88

<1> Displayed as CPF00 when occurring at regenerative unit power up. When one of the faults occurs after successfully starting the regenerative unit, the display will show CPF01. Displayed as CPF20 when occurring at regenerative unit power up. When one of the faults occurs after successfully starting the regenerative unit, the display will show CPF21.



## ■ Minor Faults and Alarms

Refer to [Table 5.3](#) for an overview of possible alarm codes. Conditions such as overvoltages can trip faults and alarms. It is important to distinguish between faults and alarms to determine the proper corrective actions. When the regenerative unit detects an alarm, the ALM indicator LED blinks and the alarm code display flashes. Most alarms trigger a digital output programmed for alarm output (H2-□□ = 10). A fault (not an alarm) is present if the ALM LED lights without blinking. Refer to [Faults on page 76](#) for information on fault codes.

**Table 5.3 Minor Fault and Alarm Displays**

Digital Operator Display		Name	Minor Fault Output (H2-□□ = 10)	Page
LED	LCD			
<i>AEr</i>	AEr	Station Number Setting Error	YES	<a href="#">89</a>
<i>Aov</i>	Aov	Power Supply Overvoltage	YES	<a href="#">89</a>
<i>AUv</i>	AUv	Power Supply Undervoltage	YES	<a href="#">89</a>
<i>bb</i>	bb	Baseblock	No output	<a href="#">89</a>
<i>bUS</i>	bUS	Option Card Communications Error	YES	<a href="#">90</a>
<i>CALL</i>	CALL	Serial Communication Transmission Error	YES	<a href="#">90</a>
<i>CE</i>	CE	MEMOBUS/Modbus Communication Error	YES	<a href="#">90</a>
<i>CoF</i>	CoF	Current Offset Fault	YES	<a href="#">91</a>
<i>CrST</i>	CrST	Cannot Reset	YES	<a href="#">91</a>
<i>CyC</i>	CyC	MECHATROLINK Communications Cycle Setting Error	YES	<a href="#">91</a>
<i>E5</i>	E5	MECHATROLINK Watchdog Timer Error	YES	<a href="#">91</a>
<i>EF0</i>	EF0	Option Card External Fault	YES	<a href="#">91</a>
<i>EF1 to EF8</i>	EF1 to EF8	External Fault (input terminal S1 to S8)	YES	<a href="#">92</a>
<i>FAn</i>	Fan	Internal Circulation Fan Fault	YES	<a href="#">92</a>
<i>Fdv</i>	Fdv	Power Supply Frequency Fault	YES	<a href="#">92</a>
<i>HCA</i>	HCA	Current Alarm	YES	<a href="#">93</a>
<i>LT-1</i>	LT-1	Cooling Fan Maintenance Time	No output <1>	<a href="#">93</a>
<i>LT-2</i>	LT-2	Capacitor Maintenance Time	No output <1>	<a href="#">93</a>
<i>LT-3</i>	LT-3	Capacitor Maintenance Time	No output <1>	<a href="#">93</a>
<i>oH</i>	oH	Heatsink Overheat	YES	<a href="#">93</a>
<i>oL2</i>	oL2	Overload	YES	<a href="#">94</a>
<i>ov</i>	ov	Overvoltage	YES	<a href="#">94</a>
<i>PAUv</i>	PAUv	Power Supply Undervoltage Pre-alarm	YES	<a href="#">94</a>
<i>PF3</i>	PF3	Input Phase Loss Detection	YES	<a href="#">94</a>
<i>PFDv</i>	PFDv	Power Supply Frequency Pre-Alarm	YES	<a href="#">94</a>
<i>SE</i>	SE	MEMOBUS/Modbus Test Mode Fault	YES	<a href="#">95</a>
<i>SrC</i>	SrC	Phase Order Fault	YES	<a href="#">95</a>
<i>Uv</i>	Uv	Undervoltage	YES	<a href="#">95</a>

<1> Output when H2-□□ = 2F.

■ Operation Errors

Table 5.4 Operation Error Displays

Digital Operator Display		Name	Page
LED	LCD		
<i>Err</i>	Err	EEPROM Write Error	<a href="#">96</a>
<i>oPE01</i>	oPE01	Unit Capacity Setting Error	<a href="#">96</a>
<i>oPE02</i>	oPE02	Parameter Setting Range Error	<a href="#">96</a>
<i>oPE03</i>	oPE03	Multi-Function Input Setting Error	<a href="#">96</a>
<i>oPE04</i>	oPE04	Terminal Board Mismatch Error	<a href="#">96</a>
<i>oPE05</i>	oPE05	Run Command Selection Error	<a href="#">97</a>
<i>oPE07</i>	oPE07	Multi-Function Analog Input Selection Error	<a href="#">97</a>
<i>oPE30</i>	oPE30	Incorrect Input Voltage Adjustment	<a href="#">97</a>

■ Errors and Displays When Using the Copy Function

Table 5.5 Copy Errors

Digital Opera		Name	Page
LED	LCD		
<i>CoPY</i>	CoPy	Writing parameter settings (flashing)	<a href="#">98</a>
<i>CPyE</i>	CPyE	Error writing data	<a href="#">98</a>
<i>CSEr</i>	CSEr	Copy unit error	<a href="#">98</a>
<i>dFpS</i>	dFpS	Model mismatch	<a href="#">98</a>
<i>End</i>	End	Task complete	<a href="#">98</a>
<i>iFEr</i>	iFEr	Communication error	<a href="#">98</a>
<i>ndAT</i>	ndAT	Model, voltage class, capacity mismatch	<a href="#">98</a>
<i>rdEr</i>	rdEr	Error reading data	<a href="#">98</a>
<i>rEAd</i>	rEAd	Reading parameter settings (flashing)	<a href="#">98</a>
<i>vAEr</i>	vAEr	Voltage class, capacity mismatch	<a href="#">98</a>
<i>vFyE</i>	vFyE	Parameter setting mismatch	<a href="#">98</a>
<i>vrFy</i>	vrFy	Comparing parameter settings (flashing)	<a href="#">98</a>

## 5.3 Fault Detection

### ◆ Fault Displays, Causes, and Possible Solutions

Table 5.6 Detailed Fault Displays, Causes, and Possible Solutions

Digital Operator Display		Fault Name	Details
$\overline{A}OU$	Aov	Power Supply Overvoltage	The input power supply voltage became equal to or higher than the Input Power Supply Overvoltage Detection Level (L8-36). 200 V Class: Approximately 277 Vac 400 V Class: Approximately 554 Vac
<b>Cause</b>		<b>Possible Solution</b>	
The input power supply voltage is too high.		Reduce the voltage to within the range in the power supply specifications.	
Digital Operator Display		Fault Name	Details
$\overline{A}Uu$	AUv	Power Supply Undervoltage	The input power supply voltage became equal to or lower than the Input Power Supply Undervoltage Detection Level. 200 V Class: Approximately 150 Vac 400 V Class: Approximately 300 Vac
<b>Cause</b>		<b>Possible Solution</b>	
The capacity of the power supply is too small.		Increase the capacity of the power supply.	
The AC fuse is open.		A transistor inside the regenerative unit was destroyed. The input wiring is ground-faulted or short-circuited. Or, the drive output is ground-faulted or short-circuited, which destroyed the output transistor. Consult with your Yaskawa representative or the nearest Yaskawa sales office.	
The distortion in the power supply is too large.		Lower the impedance of the input power supply wiring.	
A phase loss occurred in the input power supply.		Check the input power supply for phase loss or an imbalance in the interphase voltages. Investigate and correct the cause and reset the fault.	
Digital Operator Display		Fault Name	Details
$bUS$	bUS	Option Communication Error	<ul style="list-style-type: none"> <li>The connection was lost after establishing initial communication.</li> <li>Only detected when the run command frequency reference is assigned to an option card.</li> </ul>
<b>Cause</b>		<b>Possible Solution</b>	
No signal was received from the PLC.		Check for faulty wiring.	
Faulty communications wiring or an existing short circuit.		<ul style="list-style-type: none"> <li>Correct the wiring.</li> <li>Check for disconnected cables and short circuits and repair as needed.</li> </ul>	
Communication data error occurred due to noise.		Check the various options available to minimize the effects of noise. <ul style="list-style-type: none"> <li>Counteract noise in the control circuit, main circuit, and ground wiring.</li> <li>Ensure that other equipment such as switches or relays do not cause noise. Use surge absorbers if necessary.</li> <li>Use only recommended cables or other shielded line. Ground the shield on the controller side or the regenerative unit input power side.</li> <li>Separate all communication wiring from drive power lines. Install an EMC noise filter to the regenerative unit power supply input.</li> </ul>	
The option card is damaged.		Replace the option card if there are no problems with the wiring and the error continues to occur.	
The option card is not properly connected to the regenerative unit.		The connector pins on the option card do not line up properly with the connector pins on the regenerative unit. Reinstall the option card.	

### 5.3 Fault Detection

Digital Operator Display		Fault Name	Details
[CE]	CE	MEMOBUS/Modbus Communication Error	Control data was not received for the CE detection time set to H5-09.
<b>Cause</b>		<b>Possible Solution</b>	
Faulty communications wiring or an existing short circuit.		Check for faulty wiring. <ul style="list-style-type: none"> <li>• Correct the wiring.</li> <li>• Check for disconnected cables and short circuits and repair as needed.</li> </ul>	
Communication data error occurred due to noise.		Check the various options available to minimize the effects of noise. <ul style="list-style-type: none"> <li>• Counteract noise in the control circuit, main circuit, and ground wiring.</li> <li>• Use only recommended cables or other shielded line. Ground the shield on the controller side or the regenerative unit input power side.</li> <li>• Ensure that other equipment such as switches or relays do not cause noise. Use surge suppressors if required.</li> <li>• Separate all communication wiring from drive power lines. Install an EMC noise filter to the regenerative unit power supply input.</li> </ul>	
Digital Operator Display		Fault Name	Details
[CoF]	CoF	Current Offset Fault	A fault occurred in adjustment of the automatic current offset when the power supply was turned on.
<b>Cause</b>		<b>Possible Solution</b>	
An error occurred in the power supply detection circuit.		Cycle the power supply and check operation. If the fault occurs again, replace the board or regenerative unit. For information on board replacement, consult with your Yaskawa representative or the nearest Yaskawa sales office.	
Digital Operator Display		Fault Name	Details
[CPF00, CPF01]	CPF00, CPF01 <>	Control Circuit Error	A fault occurred in the control circuit.
[CPF11 to CPF22]	CPF11 to CPF22 <>		
[CPF26 to CPF35]	CPF26 to CPF35		
<b>Cause</b>		<b>Possible Solution</b>	
There is a self-diagnostic error in the control circuit.		<ul style="list-style-type: none"> <li>• Cycle power to the regenerative unit.</li> <li>• If the problem continues, replace the control board or the entire regenerative unit. Contact Yaskawa or a Yaskawa representative for instructions on replacing the control board.</li> </ul>	
Connector on the operator is damaged.		Replace the operator.	
Digital Operator Display		Fault Name	Details
[CPF02]	CPF02	A/D Conversion Error	An A/D conversion error or control circuit error occurred.
<b>Cause</b>		<b>Possible Solution</b>	
Control circuit is damaged.		Cycle power to the regenerative unit. If the problem continues, replace the control board or the entire regenerative unit. Contact Yaskawa or a Yaskawa representative for instructions on replacing the control board.	
Digital Operator Display		Fault Name	Details
[CPF03]	CPF03	Control Board Connection Error	Connection error between the control board and the regenerative unit
<b>Cause</b>		<b>Possible Solution</b>	
There is a connection error.		Turn off the power and check the connection between the control board and the regenerative unit. If the problem continues, replace the control board or the entire regenerative unit. Contact Yaskawa or a Yaskawa representative for instructions on replacing the control board.	
Regenerative unit fails to operate properly due to noise interference.		Check the various options available to minimize the effects of noise. <ul style="list-style-type: none"> <li>• Counteract noise in the control circuit, main circuit, and ground wiring.</li> <li>• Use only recommended cables or other shielded line. Ground the shield on the controller side or the regenerative unit input power side.</li> <li>• Ensure that other equipment such as switches or relays do not cause noise. Use surge suppressors if required.</li> <li>• Separate all communication wiring from regenerative unit power lines. Install an EMC noise filter to the regenerative unit power supply input.</li> </ul>	

Digital Operator Display		Fault Name	Details
<i>CPF06</i>	CPF06	EEPROM Memory Data Error	Error in the data saved to EEPROM
<b>Cause</b>		<b>Possible Solution</b>	
There is an error in EEPROM control circuit.		Turn off the power and check the connection between the control board and the regenerative unit. If the problem continues, replace the control board or the entire regenerative unit. Contact Yaskawa or a Yaskawa representative for instructions on replacing the control board.	
The power supply was switched off while parameters were being saved to the regenerative unit.		Reinitialize the regenerative unit (A1-03 = 2220, 3330).	
Digital Operator Display		Fault Name	Details
<i>CPF07</i>	CPF07	Terminal Board Connection Error	There is a faulty connection in the removable terminal block.
<i>CPF08</i>	CPF08		
<b>Cause</b>		<b>Possible Solution</b>	
There is a faulty connection between the terminal board and the control board.		<ul style="list-style-type: none"> <li>• Turn off the power and reconnect the terminal board.</li> <li>• If the problem continues, replace the control board or the entire regenerative unit. Contact Yaskawa or a Yaskawa representative for instructions on replacing the control board.</li> </ul>	
Digital Operator Display		Fault Name	Details
<i>CPF23</i>	CPF23	Control Board Connection Error	Connection error between the control board and the regenerative unit
<b>Cause</b>		<b>Possible Solution</b>	
Hardware is damaged.		Turn off the power and check the connection between the control board and the regenerative unit. If the problem continues, replace the control board or the entire regenerative unit. Contact Yaskawa or a Yaskawa representative for instructions on replacing the control board.	
Digital Operator Display		Fault Name	Details
<i>CPF24</i>	CPF24	Unit Capacity Detect Fault	The regenerative unit capacity cannot be detected correctly (regenerative unit capacity is checked when the regenerative unit is powered up).
<b>Cause</b>		<b>Possible Solution</b>	
Hardware is damaged.		If the problem continues, replace the control board or the entire regenerative unit. Contact Yaskawa or a Yaskawa representative for instructions on replacing the control board.	
Digital Operator Display		Fault Name	Details
<i>E5</i>	E5	MECHATROLINK Watchdog Timer Error	The watchdog timed out.
<b>Cause</b>		<b>Possible Solution</b>	
Data has not been received from the PLC.		Execute DISCONNECT or ALM_CLR, then issue a CONNECT command or SYNC_SET command and proceed to phase 3. Refer to the MECHATROLINK Option Technical Manual for more details on troubleshooting.	
Digital Operator Display		Fault Name	Details
<i>EF0</i>	EF0	Option Card External Fault	An external fault condition is present.
<b>Cause</b>		<b>Possible Solution</b>	
An external fault was received from the PLC and F6-03 is set to a value other than 3.		<ul style="list-style-type: none"> <li>• Remove the cause of the external fault.</li> <li>• Remove the external fault input from the PLC.</li> </ul>	
Problem with the PLC program		Check the PLC program and correct problems.	
Digital Operator Display		Fault Name	Details
<i>EF1</i>	EF1	External Fault (input terminal S1)	External fault at multi-function input terminal S1.
<i>EF2</i>	EF2	External Fault (input terminal S2)	External fault at multi-function input terminal S2.
<i>EF3</i>	EF3	External Fault (input terminal S3)	External fault at multi-function input terminal S3.
<i>EF4</i>	EF4	External Fault (input terminal S4)	External fault at multi-function input terminal S4.
<i>EF5</i>	EF5	External Fault (input terminal S5)	External fault at multi-function input terminal S5.

### 5.3 Fault Detection

<i>EF6</i>	EF6	External Fault (input terminal S6)	External fault at multi-function input terminal S6.
<i>EF7</i>	EF7	External Fault (input terminal S7)	External fault at multi-function input terminal S7.
<i>EF8</i>	EF8	External Fault (input terminal S8)	External fault at multi-function input terminal S8.
<b>Cause</b>		<b>Possible Solution</b>	
An external device tripped an alarm function.		Remove the cause of the external fault and reset the fault.	
Wiring is incorrect.		<ul style="list-style-type: none"> <li>• Properly connect the signal lines to the terminals assigned for external fault detection (H1-□□ = 20 to 2B).</li> <li>• Reconnect the signal line.</li> </ul>	
Multi-function contact input setting is incorrect.		<ul style="list-style-type: none"> <li>• Check for unused terminals set for H1-□□ = 20 to 2B (External Fault).</li> <li>• Change the terminal settings.</li> </ul>	
<b>Digital Operator Display</b>	<b>Fault Name</b>	<b>Details</b>	
<i>Err</i>	Err	EEPROM Write Error	Data cannot be written to the EEPROM
<b>Cause</b>		<b>Possible Solution</b>	
Electrical noise has corrupted data while writing to the EEPROM.		<ul style="list-style-type: none"> <li>• Press “ENTER” on the digital operator.</li> <li>• Correct the parameter setting.</li> <li>• Cycle power to the regenerative unit.</li> </ul>	
Hardware problem		If the problem continues, replace the control board or the entire regenerative unit. Contact Yaskawa or a Yaskawa representative for instructions on replacing the control board.	
<b>Digital Operator Display</b>	<b>Fault Name</b>	<b>Details</b>	
<i>FAn</i>	Fan	Internal Circulation Fan Fault	Fan or magnetic contactor failure
<b>Cause</b>		<b>Possible Solution</b>	
Internal circulation fan malfunctioned.		<ul style="list-style-type: none"> <li>• Cycle power to the regenerative unit.</li> <li>• Check for fan operation.</li> </ul>	
Fault detected in the internal circulation fan or magnetic contactor to the power supply.		<ul style="list-style-type: none"> <li>• Verify the cumulative operation time of the fan with monitor U4-03, and verify the cumulative operation time of the fan maintenance timer with U4-04.</li> <li>• If the cooling fan has exceeded its expected performance life or is damaged in any other way, follow the replacement instructions in <a href="#">Cooling Fans on page 108</a>.</li> </ul>	
<b>Digital Operator Display</b>	<b>Fault Name</b>	<b>Details</b>	
<i>Fdv</i>	Fdv	Power Supply Frequency Fault	The input power supply frequency exceeded the allowable frequency fluctuation.
<b>Cause</b>		<b>Possible Solution</b>	
A momentary power loss occurred.		Investigate and correct the cause and reset the fault. Refer to <a href="#">Diagnosing and Resetting Faults on page 99</a> .	
An input power supply wiring terminal is loose.			
The fluctuation in the voltage of the input power supply is too large.			
The AC power supply fuse is open.		<ul style="list-style-type: none"> <li>• A transistor inside the regenerative unit was destroyed.</li> <li>• The input wiring or drive output has ground faulted or short circuited.</li> </ul> Contact your Yaskawa representative or the nearest Yaskawa sales office.	
<b>Digital Operator Display</b>	<b>Fault Name</b>	<b>Details</b>	
<i>FUR</i>	FUA	AC Fuse Blowout	The power supply fuse is open.
<b>Cause</b>		<b>Possible Solution</b>	
The power supply fuse is open.		<ul style="list-style-type: none"> <li>• A transistor inside the regenerative unit was destroyed.</li> <li>• The input wiring or drive output has ground faulted or short circuited.</li> </ul> Contact your Yaskawa representative or the nearest Yaskawa sales office.	

Digital Operator Display		Fault Name	Details
FUd	FUd	DC Fuse Blowout	The DC regenerative unit output fuse is open.
<b>Cause</b>		<b>Possible Solution</b>	
The main transistor failed.		Replace the regenerative unit.	
The DC circuit fuse is open.			
The drive failed.		Replace the drive. For information on drive replacement, consult with your Yaskawa representative or the nearest Yaskawa sales office.	
Digital Operator Display		Fault Name	Details
nSE	nSE	Node Setup Error	A terminal assigned to the node setup function closed during run.
<b>Cause</b>		<b>Possible Solution</b>	
The node setup terminal closed during run.		Stop the regenerative unit when using the node setup function.	
A Run command was issued while the node setup function was active.			
Digital Operator Display		Fault Name	Details
oC	oC	Overcurrent	Regenerative unit sensors detected an output current greater than the specified overcurrent level.
<b>Cause</b>		<b>Possible Solution</b>	
A momentary power loss occurred.		Investigate and correct the cause and reset the fault. Refer to <i>Diagnosing and Resetting Faults on page 99</i> for details.	
One of the cables has shorted out or there is a grounding problem.		<ul style="list-style-type: none"> <li>• Check the motor cables.</li> <li>• Remove the short circuit and reapply power to the regenerative unit.</li> <li>• Check the resistance between the motor cables and the ground terminal ⊕.</li> <li>• Replace damaged cables.</li> </ul>	
The load is too heavy.		<ul style="list-style-type: none"> <li>• Measure the current flowing into the regenerative unit.</li> <li>• Replace the regenerative unit with a larger capacity regenerative unit if the current value exceeds the rated current.</li> <li>• Determine if there is sudden fluctuation in the current level.</li> <li>• Reduce the load to avoid sudden changes in the current level or switch to a larger regenerative unit.</li> </ul>	
Regenerative unit fails to operate properly due to noise interference.		<ul style="list-style-type: none"> <li>• Review the possible solutions provided for handling noise interference.</li> <li>• Review the section on handling noise interference on page 393 and check the control circuit lines, main circuit lines, and ground wiring.</li> </ul>	
The wiring of the power supply voltage detection circuits (r1/l11, s1/l21, t1/l31) and the wiring of the main circuit terminals (R/L1, S/L2, and T/L3) is not correct.		Correct the wiring.	
The voltage on the power supply side is very low.		<ul style="list-style-type: none"> <li>• Check the wiring.</li> <li>• Correct the wiring.</li> <li>• Check the load on the power supply of peripheral devices that are connected to the same power supply line.</li> <li>• Reduce the load.</li> </ul>	
Digital Operator Display		Fault Name	Details
oFA00	oFA00	Option Card Connection Error at Option Port CN5-A	Option compatibility error
<b>Cause</b>		<b>Possible Solution</b>	
The option card installed into port CN5-A is incompatible with the regenerative unit.		Check if the regenerative unit supports the option card to be installed. Contact Yaskawa for assistance.	

### 5.3 Fault Detection

Digital Operator Display		Fault Name	Details
<i>oFR01</i>	<i>oFA01</i>	Option Card Fault at Option Port CN5-A	Option not properly connected
<b>Cause</b>		<b>Possible Solution</b>	
The option card connection to port CN5-A is faulty.		Turn off the power and reconnect the option card.	
Digital Operator Display		Fault Name	Details
<i>oFR02</i>	<i>oFA02</i>	Same Type of Option Card Already Connected	The combination of the option cards that are connected is not correct.
<b>Cause</b>		<b>Possible Solution</b>	
The same option cards or the same type of option cards are connected to CN5-A, CN5-B, and CN5-C.		Connect the option cards correctly.	
Digital Operator Display		Fault Name	Details
<i>oFR05</i> to <i>oFR06</i>	<i>oFA05</i> to <i>oFA06</i>	Option Card Error Occurred at Option Port CN5-A	There is a fault in the option card.
<i>oFR10</i> , <i>oFR11</i>	<i>oFA10</i> , <i>oFA11</i>		
<i>oFR12</i> to <i>oFR17</i>	<i>oFA12</i> to <i>oFA17</i>	Option Card Connection Error (CN5-A)	
<i>oFR30</i> to <i>oFR43</i>	<i>oFA30</i> to <i>oFA43</i>	Communication Option Card Connection Error (CN5-A)	
<b>Cause</b>		<b>Possible Solution</b>	
Option card or hardware is damaged.		<ul style="list-style-type: none"> <li>• Cycle power to the regenerative unit.</li> <li>• If the problem continues, replace the control board or the entire regenerative unit. Contact Yaskawa or a Yaskawa representative for instructions on replacing the control board.</li> </ul>	
Digital Operator Display		Fault Name	Details
<i>oFb00</i>	<i>oFb00</i>	Option Card Fault at Option Port CN5-B	Option compatibility error
<b>Cause</b>		<b>Possible Solution</b>	
The option card installed into port CN5-B is incompatible with the regenerative unit.		Make sure the regenerative unit supports the option card to be installed. Contact Yaskawa for assistance.	
Digital Operator Display		Fault Name	Details
<i>oFb01</i>	<i>oFb01</i>	Option Card Fault at Option Port CN5-B	Option not properly connected
<b>Cause</b>		<b>Possible Solution</b>	
The option card connection to port CN5-B is faulty.		Turn off the power and reconnect the option card.	
Digital Operator Display		Fault Name	Details
<i>oFb02</i>	<i>oFb02</i>	Option Card Fault at Option Port CN5-B	Same type of option card is currently connected
<b>Cause</b>		<b>Possible Solution</b>	
An option card of the same type is already installed in option port CN5-A.		Only one of each option card type can only be installed simultaneously. Make sure only one type of option card is connected.	



Digital Operator Display	Fault Name	Details
oFb03 to oFb11	Option card error occurred at Option Port CN5-B	There is a fault in the option card.
oFb12 to oFb17	Option card error occurred at Option Port CN5-B	
<b>Cause</b>		<b>Possible Solution</b>
Option card or hardware is damaged.		<ul style="list-style-type: none"> <li>• Cycle power to the regenerative unit.</li> <li>• If the problem continues, replace the control board or the entire regenerative unit. Contact Yaskawa or a Yaskawa representative for instructions on replacing the control board.</li> </ul>
Digital Operator Display	Fault Name	Details
oFC00	Option Card Connection Error at Option Port CN5-C	Option compatibility error
<b>Cause</b>		<b>Possible Solution</b>
The option card installed into port CN5-C is incompatible with the regenerative unit.		Confirm that the regenerative unit supports the option card to be installed. Contact Yaskawa for assistance.
Digital Operator Display	Fault Name	Details
oFC01	Option Card Fault at Option Port CN5-C	Option not properly connected
<b>Cause</b>		<b>Possible Solution</b>
The option card connection to port CN5-C is faulty.		Turn the power off and reconnect the option card.
Digital Operator Display	Fault Name	Details
oFC02	Option Card Fault at Option Port CN5-C	Same type of option card is currently connected
<b>Cause</b>		<b>Possible Solution</b>
An option card of the same type is already installed in option port CN5-A or CN5-B.		Only one of each option card type can only be installed simultaneously. Make sure only one type of option card is connected.
Digital Operator Display	Fault Name	Details
oFC03 to oFC11	Option Card Error Occurred at Option Port CN5-C	There is a fault in the option card.
oFC12 to oFC17	Option Card Error Occurred at Option Port CN5-C	
<b>Cause</b>		<b>Possible Solution</b>
Option card or hardware is damaged.		<ul style="list-style-type: none"> <li>• Cycle power to the regenerative unit.</li> <li>• If the problem continues, replace the control board or the entire regenerative unit. Contact Yaskawa or a Yaskawa representative for instructions on replacing the control board.</li> </ul>
Digital Operator Display	Fault Name	Details
oFC50 to oFC55	Option Card Error Occurred at Option Port CN5-C	Option card is damaged
<b>Cause</b>		<b>Possible Solution</b>
Option card or hardware is damaged.		Refer to the option manual for details.

### 5.3 Fault Detection

Digital Operator Display		Fault Name	Details
oH	oH	Heatsink Overheat	The heatsink temperature exceeded the overheat pre-alarm level set to L8-02. The default value for L8-02 is determined by o2-04 (Unit Model Selection).
<b>Cause</b>		<b>Possible Solution</b>	
Surrounding temperature is too high.		<ul style="list-style-type: none"> <li>• Check the temperature surrounding the regenerative unit. Verify temperature is within regenerative unit specifications.</li> <li>• Improve the air circulation within the enclosure panel.</li> <li>• Install a fan or air conditioner to cool the surrounding area.</li> <li>• Remove anything near the regenerative unit that might be producing excessive heat.</li> </ul>	
Load is too heavy.		<ul style="list-style-type: none"> <li>• Measure the output current.</li> <li>• Decrease the load.</li> </ul>	
Internal cooling fan is stopped.		<ul style="list-style-type: none"> <li>• Replace the cooling fan. Refer to page <a href="#">109</a> for details.</li> <li>• After replacing the cooling fan, set parameter o4-03 to 0 to reset the cooling fan maintenance.</li> </ul>	
Digital Operator Display		Fault Name	Details
oH1	oH1	Overheat 1	The heatsink temperature exceeded the regenerative unit overheat level. Overheat level is determined by o2-04 (Unit Model Selection).
<b>Cause</b>		<b>Possible Solution</b>	
Surrounding temperature is too high.		<ul style="list-style-type: none"> <li>• Check the temperature surrounding the regenerative unit.</li> <li>• Improve the air circulation within the enclosure panel.</li> <li>• Install a fan or air conditioner to cool the surrounding area.</li> <li>• Remove anything near the regenerative unit that might be producing excessive heat.</li> </ul>	
Load is too heavy.		<ul style="list-style-type: none"> <li>• Measure the output current.</li> <li>• Reduce the load.</li> </ul>	
Internal cooling fan is stopped.		<ul style="list-style-type: none"> <li>• Replace the cooling fan. Refer to page <a href="#">109</a> for details.</li> <li>• After replacing the cooling fan, set parameter o4-03 to 0 to reset the cooling fan maintenance.</li> </ul>	
Digital Operator Display		Fault Name	Details
oL2	oL2	Overload	The thermal sensor of the regenerative unit triggered the unit overload protection.
<b>Cause</b>		<b>Possible Solution</b>	
Load is too heavy.		Reduce the load.	
Regenerative unit capacity is too small.		Replace the regenerative unit with a larger model.	
The regenerative unit does not operate.		Start regenerative unit operation first, and then start regenerative unit operation.	
Digital Operator Display		Fault Name	Details
oPr	oPr	External Digital Operator Connection Fault	The external operator has been disconnected from the regenerative unit. <b>Note:</b> An oPr fault will occur when all of the following conditions are true: <ul style="list-style-type: none"> <li>• Output is interrupted when the operator is disconnected (o2-06 = 1).</li> <li>• The Run command is assigned to the operator (b1-02 = 0 and LOCAL has been selected).</li> </ul>
<b>Cause</b>		<b>Possible Solution</b>	
External operator is not properly connected to the regenerative unit.		<ul style="list-style-type: none"> <li>• Check the connection between the operator and the regenerative unit.</li> <li>• Replace the cable if damaged.</li> <li>• Turn off the input power and disconnect the operator. Reconnect the operator and reapply regenerative unit input power.</li> </ul>	
Digital Operator Display		Fault Name	Details
ov	ov	Overvoltage	Voltage in the DC bus has exceeded the overvoltage detection level. <ul style="list-style-type: none"> <li>• 200 V Class: Approximately 410 V</li> <li>• 400 V Class: Approximately 820 V</li> </ul>
<b>Cause</b>		<b>Possible Solution</b>	
A momentary power loss occurred.		Investigate and correct the cause and reset the fault. Refer to <a href="#">Diagnosing and Resetting Faults on page 99</a> for details.	
The regenerative load is too large.		Reduce the regenerative load.	
Input power voltage is too high.		<ul style="list-style-type: none"> <li>• Check the voltage.</li> <li>• Lower input power voltage within the limits listed in the specifications.</li> </ul>	
Regenerative unit fails to operate properly due to noise interference.		<ul style="list-style-type: none"> <li>• Review the list of possible solutions provided for controlling noise.</li> <li>• Review the section on handling noise interference and check the control circuit lines, main circuit lines, and ground wiring.</li> </ul>	
The wiring of the power supply voltage detection circuits (r1/l11, r1/l21, t1/l31) and the wiring of the main circuit terminals (R/L1, S/L2, and T/L3) is not correct.		Correct the wiring.	

Digital Operator Display		Fault Name	Details
PF2	PF2	Input Power Supply Fault	Abnormal oscillation in the main circuit DC bus continued. (Applies when L8-65 is set to 1 or 2.)
<b>Cause</b>		<b>Possible Solution</b>	
The fluctuation in the voltage of the input power supply is too large.		Investigate and correct the cause and reset the fault. Refer to <a href="#">Diagnosing and Resetting Faults on page 99</a> .	
A phase loss occurred in the input power supply.			
The capacity of the power supply is too small.			
The wiring is too long.			
The phase imbalance is too large.			
<b>Digital Operator Display</b>		<b>Fault Name</b>	<b>Details</b>
PF3	PF3	Input Phase Loss Detection	The voltage balance in the three-phase power supply has broken down. (Detected when L8-69 = 1.)
<b>Cause</b>		<b>Possible Solution</b>	
The fluctuation in the voltage of the input power supply is too large.		Investigate and correct the cause and reset the fault. Refer to <a href="#">Diagnosing and Resetting Faults on page 99</a> .	
A phase loss occurred in the input power supply.			
The capacity of the power supply is too small.			
The wiring is too long.			
The phase imbalance is too large.			
<b>Digital Operator Display</b>		<b>Fault Name</b>	<b>Details</b>
SC	SC	Input Short-circuit/ Main Transistor Failure	Short circuit or ground fault is detected.
<b>Cause</b>		<b>Possible Solution</b>	
IGBT fault		<ul style="list-style-type: none"> <li>• Check the wiring to the drive.</li> <li>• Turn the power supply off and then on again to check operation.</li> </ul> If the problem continues, contact your Yaskawa representative or nearest Yaskawa sales office.	
IGBT short circuit detection circuit fault.			
<b>Digital Operator Display</b>		<b>Fault Name</b>	<b>Details</b>
SrC	SRC	Phase Order Fault	The phase order detection direction for the input power supply changed after the power supply was turned on.
<b>Cause</b>		<b>Possible Solution</b>	
The power supply phase order changed during operation.		Investigate and correct the cause and reset the fault. Refer to <a href="#">Diagnosing and Resetting Faults on page 99</a> .	
A momentary power loss occurred.			
An input power supply wiring terminal is loose.			
The fluctuation in the voltage of the input power supply is too large.			
<b>Digital Operator Display</b>		<b>Fault Name</b>	<b>Details</b>
Uv1	Uv1	Main Circuit Undervoltage	The following condition occurred in the regenerative unit when a Run Command was not being input. The main circuit DC voltage became equal to or lower than the set value of L2-05 (Undervoltage Detection Level). 200 V Class: Approximately 190 V 400 V Class: Approximately 380 V
<b>Cause</b>		<b>Possible Solution</b>	
A phase loss occurred in the input power supply.		Check the wiring of the main circuit power supply for broken wires and wiring mistakes. Correct the wiring.	
An input power supply wiring terminal is loose.		Check the terminals for looseness. Tighten the terminals to the tightening torque that is given in this manual. (See page 43.)	
Fluctuation occurred in the power supply voltage.		Check the voltage. <ul style="list-style-type: none"> <li>• Correct the voltage so that it is within the range given in the power supply specifications of the regenerative unit.</li> <li>• If there is no problem with the main circuit power supply, check the magnetic contactor in the main circuit for faults.</li> </ul>	
A power loss occurred.		Improve the power supply.	

### 5.3 Fault Detection

The main circuit capacitor circuit in the regenerative unit has deteriorated.	Check the maintenance period for the capacitor in U4-05 (Capacitor Maintenance). If the value of U4-05 has exceeded 90%, replace the board or the regenerative unit. For information on board replacement, consult with your Yaskawa representative or the nearest Yaskawa sales office.	
The operation of the relay or contactor in the inrush current protection circuit in the regenerative unit failed.	Cycle the power supply and see if the fault occurs again. • If the fault occurs repeatedly, replace the board or the regenerative unit. For information on board replacement, consult with your Yaskawa representative or the nearest Yaskawa sales office. Check the maintenance period for the inrush prevention relay in U4-06 (Soft Charge Bypass Relay Maintenance). • If the value of U4-06 has exceeded 90%, replace the board or the regenerative unit. For information on board replacement, consult with your Yaskawa representative or the nearest Yaskawa sales office.	
A fault occurred in the power supply device.	Check the wiring of the power supply device. Correct the wiring.	
A fault occurred in the power supply.	A fault occurred in the power supply.	
A fault occurred in power supply voltage detection.	Check the wiring. Correct the wiring.	
Digital Operator Display	Fault Name	Details
Uv2	Uv2 Control Power Supply Voltage Fault	Voltage is too low for the control regenerative unit input power.
Cause		Possible Solution
Internal circuitry is damaged.		<ul style="list-style-type: none"> <li>• Cycle power to the regenerative unit. Check if the fault reoccurs.</li> <li>• If the problem continues, replace either the control board or the entire regenerative unit. For instructions on replacing the control board, contact Yaskawa or a Yaskawa representative.</li> </ul>
Digital Operator Display	Fault Name	Details
Uv3	Uv3 Undervoltage 3 (Soft-Charge Bypass Circuit Fault)	The soft-charge bypass circuit failed.
Cause		Possible Solution
The relay or contactor on the soft-charge bypass circuit is damaged.		<ul style="list-style-type: none"> <li>• Cycle power to the regenerative unit and see if the fault reoccurs.</li> <li>• If the problem continues, replace either the control board or the entire regenerative unit. For instructions on replacing the control board, contact Yaskawa or a Yaskawa representative.</li> <li>• Check monitor U4-06 for the performance life of the soft-charge bypass.</li> <li>• Replace either the control board or the entire regenerative unit if U4-06 exceeds 90%. For instructions on replacing the control board, contact Yaskawa or a Yaskawa representative.</li> </ul>

<1> If the fault occurs when starting the regenerative unit, CPF00 or CPF20 is displayed. If it occurs during operation, CPF01 or CPF21 is displayed.

## 5.4 Alarm Detection

### ◆ Alarm Codes, Causes, and Possible Solutions

Alarms are regenerative unit protection functions that do not necessarily cause the regenerative unit to stop. After removing the cause of an alarm, the regenerative unit will return to the same status it was before the alarm occurred.

When an alarm has been triggered, the ALM light on the digital operator display blinks and the alarm code display flashes. If a multi-function output is set for an alarm (H2-□□ = 10), that output terminal will be triggered.

**Note:** If a multi-function output is set to close when an alarm occurs (H2-□□ = 10), it will also close when maintenance periods are reached, triggering alarms LT-1 through LT-4 (triggered only if H2-□□ = 2F).

**Table 5.7 Alarm Codes, Causes, and Possible Solutions**

Digital Operator Display		Minor Fault Name	Detail	Alarm Output (H2-□□ = 10)
AEr	AEr	Communication Option Station Number Setting Error (CC-Link, CANopen, MECHATROLINK)	Option card node address is outside of the acceptable setting range.	YES
<b>Cause</b>		<b>Possible Solutions</b>		
Station number is set outside the possible setting range.		Set the station number of the option card correctly.		
Digital Operator Display		Minor Fault Name	Detail	Alarm Output (H2-□□ = 10)
Aov	Aov	Power Supply Overvoltage	The input power supply voltage became equal to or higher than the Input Power Supply Overvoltage Detection Level. 200 V Class: Approximately 277 Vac 400 V Class: Approximately 554 Vac	YES
<b>Cause</b>		<b>Possible Solutions</b>		
The input power supply voltage is too high.		Reduce the voltage to within the range in the power supply specifications.		
Digital Operator Display		Minor Fault Name	Detail	Alarm Output (H2-□□ = 10)
AUv	AUv	Power Supply Undervoltage	The input power supply voltage became equal to or lower than the Input Power Supply Undervoltage Detection Level. 200 V Class: Approximately 150 Vac 400 V Class: Approximately 300 Vac	YES
<b>Cause</b>		<b>Possible Solutions</b>		
The power supply voltage is low.		Increase the power supply voltage.		
A phase loss occurred in the input power supply.		Check the input power supply for phase loss or an imbalance in the interphase voltages. Investigate and correct the cause and reset the fault.		
Voltage detection failed.		Correctly wire r1/ℓ11, 41/ℓ21, and t1/ℓ31.		
Digital Operator Display		Minor Fault Name	Detail	Alarm Output (H2-□□ = 10)
bb	bb	Baseblock	Output interrupted as indicated by an external baseblock signal.	N.A.
<b>Cause</b>		<b>Possible Solutions</b>		
External baseblock signal was entered via one of the multi-function input terminals (S1 to S8).		Check external sequence and baseblock signal input timing.		

## 5.4 Alarm Detection

Digital Operator Display		Minor Fault Name	Detail	Alarm Output (H2-□□ = 10)
<i>bUS</i>	bUS	Option Communication Error	<ul style="list-style-type: none"> <li>The connection was lost after initial communication was established.</li> <li>Assign a Run command frequency reference to the option.</li> </ul>	YES
<b>Cause</b>		<b>Possible Solutions</b>		
Connection is broken or master controller stopped communicating.		<ul style="list-style-type: none"> <li>Check for faulty wiring.</li> <li>Correct the wiring.</li> <li>Check for disconnected cables and short circuits. Repair as needed.</li> </ul>		
Option is damaged.		If there are no problems with the wiring and the fault continues to occur, replace the option.		
The option is not properly connected to the regenerative unit.		<ul style="list-style-type: none"> <li>The connector pins on the option are not properly lined up with the connector pins on the regenerative unit.</li> <li>Reinstall the option.</li> </ul>		
A data error occurred due to noise.		<ul style="list-style-type: none"> <li>Check options available to minimize the effects of noise.</li> <li>Take steps to counteract noise in the control circuit wiring, main circuit lines and ground wiring.</li> <li>Try to reduce noise on the controller side.</li> <li>Use surge absorbers on magnetic contactors or other equipment causing the disturbance.</li> <li>Use recommended cables or some other type of shielded line. Ground the shield to the controller side or on the input power side.</li> <li>Separate the wiring for communication devices from the regenerative unit input power lines. Install an EMC noise filter to the regenerative unit input power.</li> </ul>		
Digital Operator Display		Minor Fault Name	Detail	Alarm Output (H2-□□ = 10)
<i>CALL</i>	CALL	Serial Communication Transmission Error	Communication has not yet been established.	YES
<b>Cause</b>		<b>Possible Solutions</b>		
Communications wiring is faulty, there is a short circuit, or something is not connected properly.		<ul style="list-style-type: none"> <li>Check for wiring errors.</li> <li>Correct the wiring.</li> <li>Check for disconnected cables and short circuits. Repair as needed.</li> </ul>		
Programming error on the master side.		Check communications at start-up and correct programming errors.		
Communications circuitry is damaged.		<ul style="list-style-type: none"> <li>Perform a self-diagnostics check.</li> <li>If the problem continues, replace either the control board or the entire regenerative unit. For instructions on replacing the control board, contact Yaskawa or your nearest sales representative.</li> </ul>		
Termination resistor setting is incorrect.		Install a termination resistor at both ends of a communication line. Set the internal termination resistor switch correctly on slave regenerative units. Place DIP switch S2 to the ON position.		
Digital Operator Display		Minor Fault Name	Detail	Alarm Output (H2-□□ = 10)
<i>CE</i>	CE	MEMOBUS/Modbus Communication Error	Control data was not received correctly for two seconds.	YES
<b>Cause</b>		<b>Possible Solutions</b>		
A data error occurred due to noise.		<ul style="list-style-type: none"> <li>Check options available to minimize the effects of noise.</li> <li>Take steps to counteract noise in the control circuit wiring, main circuit lines, and ground wiring.</li> <li>Reduce noise on the controller side.</li> <li>Use surge absorbers for the magnetic contactors or other components that may be causing the disturbance.</li> <li>Use only recommended shielded line. Ground the shield on the controller side or on the regenerative unit input power side.</li> <li>Separate all wiring for communication devices from regenerative unit input power lines. Install an EMC noise filter to the regenerative unit input power supply.</li> </ul>		
Communication protocol is incompatible.		<ul style="list-style-type: none"> <li>Check the H5 parameter settings and the protocol setting in the controller.</li> <li>Ensure settings are compatible.</li> </ul>		
The CE detection time (H5-09) is set shorter than the time required for a communication cycle to take place.		<ul style="list-style-type: none"> <li>Check the PLC.</li> <li>Change the software settings in the PLC.</li> <li>Set a longer CE detection time using parameter H5-09.</li> </ul>		
Incompatible PLC software settings or there is a hardware problem.		<ul style="list-style-type: none"> <li>Check the PLC.</li> <li>Remove the cause of the error on the controller side.</li> </ul>		
Communications cable is disconnected or damaged.		<ul style="list-style-type: none"> <li>Check the connector to make sure the cable has a signal.</li> <li>Replace the communications cable.</li> </ul>		

Digital Operator Display		Minor Fault Name	Detail	Alarm Output (H2-□□ = 10)
CoF	CoF	Current Offset Fault	A fault occurred in adjustment of the automatic current offset when the power supply was turned on.	YES
<b>Cause</b>		<b>Possible Solutions</b>		
A fault occurred in the current detection circuit.		Cycle the power supply and check operation. If the fault occurs again, replace the board or regenerative unit. For information on board replacement, consult with your Yaskawa representative or the nearest Yaskawa sales office.		
Digital Operator Display		Minor Fault Name	Detail	Alarm Output (H2-□□ = 10)
CrST	CrST	Cannot Reset	A fault reset command was entered while the Run command was still present.	YES
<b>Cause</b>		<b>Possible Solutions</b>		
Fault reset was being executed when a Run command was entered.		<ul style="list-style-type: none"> <li>• Ensure that a Run command cannot be entered from the external terminals or option during fault reset.</li> <li>• Turn off the Run command.</li> </ul>		
Digital Operator Display		Minor Fault Name	Detail	Alarm Output (H2-□□ = 10)
CyC	CyC	MECHATROLINK Communications Cycle Setting Error	The MECHATROLINK option card is not set correctly.	YES
<b>Cause</b>		<b>Possible Solutions</b>		
The communications cycle of the MECHATROLINK option card is out of range.		Correct the setting.		
Digital Operator Display		Minor Fault Name	Detail	Alarm Output (H2-□□ = 10)
E5	E5	MECHATROLINK Watchdog Timer Error	A Watchdog Timer Error was detected.	YES
<b>Cause</b>		<b>Possible Solutions</b>		
There is no continuity in the watchdog timer in the data that is sent by the host controller.		Execute the DISCONNECT or ALM_CLR command, and then move to phase 3 again with the CONNECT or SYNC_SET command.		
Digital Operator Display		Minor Fault Name	Detail	Alarm Output (H2-□□ = 10)
EF0	EF0	Option Card External Fault	An external fault condition is present.	YES
<b>Cause</b>		<b>Possible Solutions</b>		
An external fault was received from the PLC with F6-03 set to 3, which allows the regenerative unit to continue running after an external fault occurs.		<ul style="list-style-type: none"> <li>• Remove the cause of the external fault.</li> <li>• Remove the external fault input from the PLC.</li> </ul>		
There is a problem with the PLC program.		Check the PLC program and correct problems.		



## 5.4 Alarm Detection

Digital Operator Display		Minor Fault Name	Detail	Alarm Output (H2-□□ = 10)
<i>EF1</i>	EF1	External Fault (Input Terminal S1)	External fault at multi-function input terminal S1.	YES
<i>EF2</i>	EF2	External fault (input terminal S2)	External fault at multi-function input terminal S2.	
<i>EF3</i>	EF3	External fault (input terminal S3)	External fault at multi-function input terminal S3.	
<i>EF4</i>	EF4	External fault (input terminal S4)	External fault at multi-function input terminal S4.	
<i>EF5</i>	EF5	External fault (input terminal S5)	External fault at multi-function input terminal S5.	
<i>EF6</i>	EF6	External fault (input terminal S6)	External fault at multi-function input terminal S6.	
<i>EF7</i>	EF7	External fault (input terminal S7)	External fault at multi-function input terminal S7.	
<i>EF8</i>	EF8	External fault (input terminal S8)	External fault at multi-function input terminal S8.	
		<b>Cause</b>	<b>Possible Solutions</b>	
		An external device has tripped an alarm function.	Remove the cause of the external fault and reset the multi-function input value. Refer to <a href="#">Stopping the Regenerative Unit for Faults in Peripheral Devices on page 68</a> for details.	
		Wiring is incorrect.	<ul style="list-style-type: none"> <li>Ensure the signal lines have been connected properly to the terminals assigned for external fault detection (H1-□□=24 to 27, 2C to 2F).</li> <li>Reconnect the signal line. Refer to <a href="#">Stopping the Regenerative Unit for Faults in Peripheral Devices on page 68</a> for details.</li> </ul>	
		Multi-function contact inputs are set incorrectly.	<ul style="list-style-type: none"> <li>Check if the unused terminals have been set for H1-□□ = 24 to 27, 2C to 2F (External Fault).</li> <li>Change the terminal settings. Refer to <a href="#">Stopping the Regenerative Unit for Faults in Peripheral Devices on page 68</a> for details.</li> </ul>	
Digital Operator Display		Minor Fault Name	Detail	Alarm Output (H2-□□ = 10)
<i>FAn</i>	Fan	Internal Circulation Fan Fault	The internal circulation fan in the regenerative unit is faulty.	YES
		<b>Cause</b>	<b>Possible Solutions</b>	
		An internal circulation fan is faulty.	Cycle the power supply and see if the fault occurs again. Check the operation of the internal circulation fans. Check U4-03 (Cooling Fan Operation Time) and U4-04 (Cooling Fan Maintenance Display). If the life of the internal circulation fans has expired or if a fan is faulty, perform fan replacement according to instructions in this manual.	
		An internal circulation fan or MC power supply is faulty.	Cycle the power supply and see if the fault occurs again. If the fault occurs repeatedly, replace the board or the regenerative unit. For information on board replacement, consult with your Yaskawa representative or the nearest Yaskawa sales office.	
Digital Operator Display		Minor Fault Name	Detail	Alarm Output (H2-□□ = 10)
<i>Fdv</i>	Fdv	Power Supply Frequency Fault	The input power supply frequency exceeded the allowable frequency fluctuation.	YES
		<b>Cause</b>	<b>Possible Solutions</b>	
		A momentary power loss occurred.	Investigate and correct the cause and reset the fault. Refer to <a href="#">Diagnosing and Resetting Faults on page 99</a> .	
		An input power supply wiring terminal is loose.		
		The fluctuation in the voltage of the input power supply is too large.		
		The AC power supply fuse is open.	<ul style="list-style-type: none"> <li>A transistor inside the regenerative unit was destroyed.</li> <li>The input wiring or drive output has ground faulted or short circuited.</li> </ul> Contact your Yaskawa representative or the nearest Yaskawa sales office.	
		The phase rotation direction has changed in the input power supply.	Correct the wiring.	
		The detected power supply frequency exceeded the allowable value.	Improve the power supply.	



Digital Operator Display		Minor Fault Name	Detail	Alarm Output (H2-□□ = 10)
HCA	HCA	Current Alarm	Regenerative unit current exceeded overcurrent warning level (150% of the rated current).	YES
<b>Cause</b>		<b>Possible Solutions</b>		
Load is too heavy.		Reduce the load for applications with repetitive operations (i.e., stops and starts), or replace the regenerative unit.		
Digital Operator Display		Minor Fault Name	Detail	Alarm Output (H2-□□ = 10)
LT-1	LT-1	Cooling Fan Maintenance Time	The cooling fan has reached its expected maintenance period and may need to be replaced. <b>Note:</b> An alarm output (H2-□□ = 10) will only be triggered if both (H2-□□ = 2F and H2-□□ = 10) are set.	YES
<b>Cause</b>		<b>Possible Solutions</b>		
The cooling fan has reached 90% of its expected performance life.		Replace the cooling fan and set o4-03 to 0 to reset the Maintenance Monitor.		
Digital Operator Display		Minor Fault Name	Detail	Alarm Output (H2-□□ = 10)
LT-2	LT-2	Capacitor Maintenance Time	The main circuit and control circuit capacitors are nearing the end of their expected performance life. <b>Note:</b> An alarm output (H2-□□ = 10) will only be triggered if H2-□□ = 2F.	YES
<b>Cause</b>		<b>Possible Solutions</b>		
The main circuit and control circuit capacitors have reached 90% of their expected performance lives.		Replace either the control board or the entire regenerative unit. For instructions on replacing the control board, contact Yaskawa or your nearest sales representative.		
Digital Operator Display		Minor Fault Name	Detail	Alarm Output (H2-□□ = 10)
LT-3	LT-3	Soft Charge Bypass Relay Maintenance Time	The DC bus soft charge relay is nearing the end of its expected performance life. <b>Note:</b> An alarm output (H2-□□ = 10) will only be triggered if H2-□□ = 2F.	YES
<b>Cause</b>		<b>Possible Solutions</b>		
The DC bus soft charge relay has reached 90% of expected performance life.		Replace either the control board or the entire regenerative unit. For instructions on replacing the control board, contact Yaskawa or your nearest sales representative.		
Digital Operator Display		Minor Fault Name	Detail	Alarm Output (H2-□□ = 10)
oH	oH	Heatsink Overheat	The temperature of the heatsink exceeded the overheat pre-alarm level set to L8-02 (90-100 °C). Default value for L8-02 is determined by o2-04 (Unit Model Selection).	YES
<b>Cause</b>		<b>Possible Solutions</b>		
Surrounding temperature is too high		<ul style="list-style-type: none"> <li>• Check the surrounding temperature.</li> <li>• Improve the air circulation within the enclosure panel.</li> <li>• Install a fan or air conditioner to cool surrounding area.</li> <li>• Remove anything near regenerative unit that may cause extra heat.</li> </ul>		
Airflow around the regenerative unit is restricted.		<ul style="list-style-type: none"> <li>• Provide proper installation space around the regenerative unit as indicated in the manual. Refer to <i>Installation Orientation and Spacing on page 21</i> for details.</li> <li>• Allow for the proper space and ensure that there is sufficient circulation around the control panel.</li> <li>• Check for dust or other foreign materials clogging the cooling fan.</li> <li>• Clear debris caught in the fan that restricts air circulation.</li> </ul>		
The ambient temperature is too high.		Check the ambient temperature. <ul style="list-style-type: none"> <li>• Improve ventilation in the control panel.</li> <li>• Install a cooling device (e.g., a cooling fan or air conditioner) and lower the ambient temperature.</li> <li>• If there are heat-generating objects nearby, remove them.</li> </ul>		
The load is too large.		Measure the output current. Lower the load.		
Internal cooling fan has stopped.		<ul style="list-style-type: none"> <li>• Replace the cooling fan. Refer to page 109 for details.</li> <li>• After replacing the regenerative unit, set parameter o4-03 to 0 to reset the cooling fan operation time.</li> </ul>		

## 5.4 Alarm Detection

Digital Operator Display		Minor Fault Name	Detail	Alarm Output (H2-□□ = 10)
oL2	oL2	Overload	The thermal sensor of the regenerative unit triggered the unit overload protection.	YES
<b>Cause</b>		<b>Possible Solutions</b>		
Load is too heavy.		Reduce the load.		
The regenerative unit does not operate.		Start regenerative unit operation first, and then start regenerative unit operation.		
Digital Operator Display		Minor Fault Name	Detail	Alarm Output (H2-□□ = 10)
ov	ov	DC Bus Overvoltage	The DC bus voltage exceeded the trip point. • 200 V Class: Approximately 410 V • 400 V Class: Approximately 820 V	YES
<b>Cause</b>		<b>Possible Solutions</b>		
Electrical noise interference causes the regenerative unit to operate incorrectly.		<ul style="list-style-type: none"> <li>Review possible solutions for handling noise interference.</li> <li>Review section on handling noise interference and check control circuit lines, main circuit lines and ground wiring.</li> <li>If the magnetic contactor is identified as a source of noise, install a surge protector to the MC coil.</li> </ul>		
		Set number of fault restarts (L5-01) to a value other than 0.		
There was a regenerative load while the regenerative unit is stopped.		Operate the regenerative unit.		
The power supply voltage is too high.		Lower the voltage so that it is within the power supply specifications of the regenerative unit.		
There is a regenerative load while the regenerative unit is stopped.		Operate the regenerative unit.		
The wiring of the power supply voltage detection circuits (r1/ℓ11, s1/ℓ21, t1/ℓ31) and the wiring of the main circuit terminals (R/L1, S/L2, and T/L3) is not correct.		Check the wiring. Correct the wiring.		
Digital Operator Display		Minor Fault Name	Detail	Alarm Output (H2-□□ = 10)
PAUv	PAUv	Power Supply Undervoltage Pre-Alarm	The input power supply voltage became equal to or lower than the Input Power Supply Undervoltage Detection Level. 200 V Class: Approximately 150 Vac 400 V Class: Approximately 300 Vac The regenerative unit enters the baseblock state during pre-alarm. When the input supply voltage is restored during the pre-alarm, the regenerative unit will release the base block and continue to operate.	YES
<b>Cause</b>		<b>Possible Solutions</b>		
The power supply voltage is low.		Increase the power supply voltage.		
A phase loss occurred in the input power supply.		Check the input power supply for phase loss or an imbalance in the interphase voltages. Investigate and correct the cause and reset the fault.		
Voltage detection failed.		Check r1/ℓ11, s1/ℓ21, t1/ℓ31 to see if they are wired correctly.		
Digital Operator Display		Minor Fault Name	Detail	Alarm Output (H2-□□ = 10)
PF3	PF3	Input Phase Loss Detection	Abnormal oscillation continued in the input power supply voltage. (Detected when L8-69 = 1.)	YES
<b>Cause</b>		<b>Possible Solutions</b>		
The fluctuation in the voltage of the input power supply is too large.		Investigate the cause and implement countermeasures. Refer to <a href="#">Diagnosing and Resetting Faults on page 99</a> for details.		
A phase loss occurred in the input power supply.				
The interphase voltage balance is bad.				
Digital Operator Display		Minor Fault Name	Detail	Alarm Output (H2-□□ = 10)
PFDv	PFDv	Power Supply Frequency Pre-Alarm	The input power supply frequency fluctuates more than ±15 Hz. The regenerative unit enters the baseblock state during pre-alarm. When the input supply frequency returns to normal conditions, the regenerative unit will release the base block and continue to operate.	YES
<b>Cause</b>		<b>Possible Solutions</b>		
Momentary power loss has occurred.		Activate the momentary power loss ride-thru.		
Voltage distortion is large.		Increase the power supply capacity.		
Voltage detection failure		Confirm r1/ℓ11, s1/ℓ21, t1/ℓ31 are correctly wired.		
Phase loss has occurred.		Confirm the power supply and regenerative unit is correctly connected.		

Digital Operator Display		Minor Fault Name	Detail	Alarm Output (H2-□□ = 10)
SE	SE	MEMOBUS/Modbus Test Mode Fault	A MEMOBUS/Modbus communications test was performed during operation.	YES
<b>Cause</b>		<b>Possible Solutions</b>		
A fault occurred during MEMOBUS/Modbus Communications Test Mode.		Always stop the operation of the regenerative unit before you perform MEMOBUS/Modbus communications tests.		
Digital Operator Display		Minor Fault Name	Detail	Alarm Output (H2-□□ = 10)
SrE	SRC	Phase Order Fault	The phase order detection direction for the input power supply changed after the power supply was turned on.	YES
<b>Cause</b>		<b>Possible Solutions</b>		
A momentary power loss occurred.		Investigate and correct the cause and reset the fault. Refer to <i>Diagnosing and Resetting Faults on page 99</i> for details.		
An input power supply wiring terminal is loose.				
The fluctuation in the voltage of the input power supply is too large.				
Digital Operator Display		Minor Fault Name	Detail	Alarm Output (H2-□□ = 10)
Uu	Uv	Undervoltage	One of the following conditions was true when the regenerative unit was stopped and a Run command was entered: <ul style="list-style-type: none"> <li>DC bus voltage dropped below the level specified in L2-05.</li> <li>Contactors to suppress inrush current in the regenerative unit were opened.</li> <li>Low voltage in the control regenerative unit input power. This alarm outputs only if L2-01 is not 0 and DC bus voltage is under L2-05.</li> </ul>	YES
<b>Cause</b>		<b>Possible Solutions</b>		
Phase loss in the regenerative unit input power.		Check for wiring errors in the main circuit input power. Correct the wiring.		
Loose wiring in the regenerative unit input power terminals.		<ul style="list-style-type: none"> <li>Ensure the terminals have been properly tightened.</li> <li>Apply the tightening torque to the terminals as specified. Refer to <i>Wire Gauges and Tightening Torque on page 43</i>.</li> </ul>		
There is a problem with the regenerative unit input power voltage.		<ul style="list-style-type: none"> <li>Check the voltage.</li> <li>Lower the voltage of the regenerative unit input power so that it is within the limits listed in the specifications.</li> </ul>		
A power loss occurred.		Improve the power supply.		
Internal circuitry is worn.		<ul style="list-style-type: none"> <li>Check the maintenance time for the capacitors (U4-05).</li> <li>Replace either the control board or the entire regenerative unit if U4-05 exceeds 90%. For instructions on replacing the control board, contact Yaskawa or your nearest sales representative.</li> </ul>		
The regenerative unit input power transformer is too small and voltage drops when the power is switched on.		<ul style="list-style-type: none"> <li>Check for an alarm when the magnetic contactor, line breaker, and leakage breaker are closed.</li> <li>Check the capacity of the regenerative unit input power transformer.</li> </ul>		
Air inside the regenerative unit is too hot.		Check the temperature inside the regenerative unit.		
The CHARGE light is broken or disconnected.		Replace either the control board or the entire regenerative unit. For instructions on replacing the control board, contact Yaskawa or your nearest sales representative.		
Digital Operator Display		Minor Fault Name	Detail	Alarm Output (H2-□□ = 10)
vrE	vrE	Resonance Detection	A filter resonance fault was detected or there is a harmonic component on the power supply side.	YES
<b>Cause</b>		<b>Possible Solutions</b>		
There is noise on the power supply line.		Investigate the source of the noise and implement countermeasures.		

## 5.5 Operator Programming Errors

### ◆ Operator Programming Error Codes, Causes, and Possible Solutions

An Operator Programming Error (oPE) occurs when a contradictory parameter is set or an individual parameter is set to an inappropriate value.

The regenerative unit will not operate until the parameter or parameters causing the problem are set correctly. An oPE, however, does not trigger an alarm or fault output. If an oPE occurs, investigate the cause and refer to [Table 5.8](#) for the appropriate action. When an oPE appears on the operator display, press the ENTER button to view U1-18 and see which parameter is causing the oPE.

**Table 5.8 oPE Codes, Causes, and Possible Solutions**

Digital Operator Display		Error Name	Detail
Err	Err	EEPROM Write Error	A verification mismatch occurred when writing data to the EEPROM.
<b>Cause</b>		<b>Possible Solutions</b>	
The data was corrupted by noise when writing data to the EEPROM.		<ul style="list-style-type: none"> <li>Press .</li> <li>Set the parameters again.</li> <li>Cycle the power supply. Refer to <a href="#">Diagnosing and Resetting Faults on page 99</a> for details.</li> </ul>	
EEPROM Hardware Failure		Replace the board or regenerative unit. For information on board replacement, consult with your Yaskawa representative or the nearest Yaskawa sales office.	
Digital Operator Display		Error Name	Detail
oPE01	oPE01	Unit Capacity Setting Error	Unit capacity and the value set to o2-04 do not match.
<b>Cause</b>		<b>Possible Solutions</b>	
The Unit Model Selection (o2-04) and the actual capacity of the regenerative unit are not the same.		Correct the value set to o2-04.	
Digital Operator Display		Error Name	Detail
oPE02	oPE02	Parameter Range Setting Error	Use U1-18 to find parameters set outside the range.
<b>Cause</b>		<b>Possible Solutions</b>	
Parameters were set outside the possible setting range.		Set parameters to the proper values.	
<b>Note:</b> When multiple errors occur simultaneously, other errors are given precedence over oPE02.			
Digital Operator Display		Error Name	Detail
oPE03	oPE03	Multi-Function Input Selection Error	A contradictory setting is assigned to multi-function contact inputs H1-01 to H1-08.
<b>Cause</b>		<b>Possible Solutions</b>	
The same function is assigned to two multi-function inputs. Excludes “Not used” and “External Fault.”		<ul style="list-style-type: none"> <li>Ensure all multi-function inputs are assigned to different functions.</li> <li>Re-enter the multi-function settings to ensure this does not occur.</li> </ul>	
Digital Operator Display		Error Name	Detail
oPE04	oPE04	Terminal Board Mismatch Error	The regenerative unit or the removable terminal block with parameter backup was replaced.
<b>Cause</b>		<b>Possible Solutions</b>	
The regenerative unit was replaced (but the removable terminal block with parameter backup was not replaced).		Set A1-03 to 5550 to load the parameter settings stored in the terminal board to the regenerative unit. Initialize parameters after regenerative unit replacement by setting A1-03 to 2220.	
The removable terminal block with parameter backup was replaced.			

Digital Operator Display		Error Name	Detail
oPE05	oPE05	Run Command Selection Error	The settings for the Run Command or Bus Voltage Command are not correct.
<b>Cause</b>		<b>Possible Solutions</b>	
The Run Command Selection 1 is assigned to an option card (b1-02 = 3) and an input option card is not connected to the unit.		Reconnect the input option card to the regenerative unit.	
Digital Operator Display		Error Name	Detail
oPE07	oPE07	Multi-Function Analog Input Selection Error	A contradictory setting is assigned to multi-function analog inputs H3-02, H3-10, or H3-06.
<b>Cause</b>		<b>Possible Solutions</b>	
At least two of these parameters have the same setting: H3-02, H3-10, or H3-06.		Change the settings to H3-02, H3-10, and H3-06 so that functions no longer conflict. <b>Note:</b> Both 1F (Through mode) and F (Through mode) can be set to H3-02, H3-10, or H3-06 simultaneously.	
Digital Operator Display		Error Name	Detail
oPE30	oPE30	Incorrect Input Voltage Adjustment	The input voltage offset adjustment has not been performed.
<b>Cause</b>		<b>Possible Solutions</b>	
<ul style="list-style-type: none"> <li>The setting of o2-04 (Unit Model Selection) changed.</li> <li>ERPROM failed for the input voltage offset.</li> </ul>		For information on clearing the fault, consult with your Yaskawa representative or the nearest Yaskawa sales office.	

## 5.6 Copy Function Related Displays

### ◆ Tasks, Errors, and Troubleshooting

The table below lists the messages and errors that may appear when using the Copy function. When executing the tasks offered by the Copy function, the operator will indicate the task being performed. When an error occurs, a code appears on the operator to indicate the error. Note that errors related to the Copy function do not trigger a multifunction output terminal that has been set up to close when a fault or alarm occurs. To clear an error, simply press any key on the operator and the error display will disappear.

**Table 5.9** lists the corrective action that can be taken when an error occurs.

- Note:**
1. Whenever using the copy function, the regenerative unit should be fully stopped.
  2. The regenerative unit will not accept a Run command while the Copy function is being executed.
  3. Parameters can only be saved to a regenerative unit when the voltage class, capacity, control mode, and software version match.

**Table 5.9 Copy Function Task and Error Displays**

Digital Operator Display		Error Name
<i>CoPY</i>	CoPy	Writing Parameter Settings (flashing)
<i>CPyE</i>	CPyE	Error Writing Data
<i>CSEr</i>	CSEr	Copy Unit Error
<i>dFPS</i>	dFPS	Model Mismatch
<i>End</i>	End	Task Complete
<i>iFEr</i>	iFEr	Communication Error
<i>ndAT</i>	ndAT	Model, Voltage Class, Capacity Mismatch
<i>rdEr</i>	rdEr	Error Reading Data
<i>rEAd</i>	rEAd	Reading Parameter Settings (flashing)
<i>vAEr</i>	vAEr	Voltage Class, Capacity Mismatch
<i>vFyE</i>	vFyE	Parameter settings in the regenerative unit and those saved to the copy function are not the same
<i>vrFy</i>	vrFy	Comparing Parameter Settings (flashing)

## 5.7 Diagnosing and Resetting Faults

When a fault occurs and the regenerative unit stops, follow the instructions below to remove whatever conditions triggered the fault, then restart the regenerative unit.

### ◆ Fault Reset Methods

When a fault occurs, the cause of the fault must be removed and the regenerative unit must be restarted. The table below lists the different ways to restart the regenerative unit.

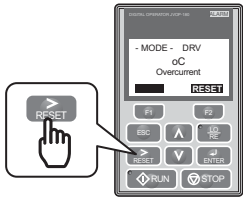
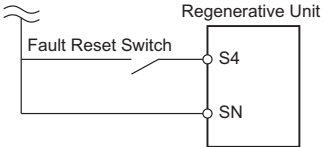
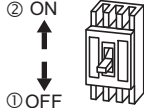
After the Fault Occurs	Procedure	
Fix the cause of the fault, restart the regenerative unit, and reset the fault	Press  on the digital operator when the error code is displayed.	
Resetting via Fault Reset Digital Input S4	Close then open the fault signal digital input via terminal S4. S4 is set for "Fault Reset" as default (H1-04 = 14).	
Turn off the main power supply if the above methods do not reset the fault. Reapply power after the digital operator display has turned off.		

**Note:** If the Run command is present, the regenerative unit will disregard any attempts to reset the fault. Remove the Run command before attempting to clear a fault situation.





# Periodic Inspection & Maintenance

---

This chapter describes the periodic inspection and maintenance of the regenerative unit to ensure that it receives the proper care to maintain overall performance.

<b>6.1</b>	<b>SECTION SAFETY</b> .....	<b>102</b>
<b>6.2</b>	<b>INSPECTION</b> .....	<b>104</b>
<b>6.3</b>	<b>PERIODIC MAINTENANCE</b> .....	<b>106</b>
<b>6.4</b>	<b>COOLING FANS</b> .....	<b>108</b>
<b>6.5</b>	<b>REGENERATIVE UNIT REPLACEMENT</b> .....	<b>118</b>

## 6.1 Section Safety

### WARNING

#### Electrical Shock Hazard

**Do not connect or disconnect wiring while the power is on.**

Failure to comply could result in death or serious injury.

Before servicing, disconnect all power to the equipment. The internal capacitor remains charged even after the power supply is turned off. The charge indicator LED will extinguish when the DC bus voltage is below 50 Vdc. To prevent electric shock, wait for at least the time specified on the warning label; after all indicators are OFF, measure for unsafe voltages to confirm the unit is safe prior to servicing.

**Do not operate equipment with covers removed.**

Failure to comply could result in death or serious injury.

The diagrams in this section may show units without covers or safety shields to show details. Be sure to reinstall covers or shields before operating the unit and run the unit according to the instructions described in this manual.

**Do not remove covers or touch circuit boards while the power is on.**

Failure to comply could result in death or serious injury.

**Do not allow unqualified personnel to perform work on the unit.**

Failure to comply could result in death or serious injury.

Installation, maintenance, inspection, and servicing must be performed only by authorized personnel familiar with installation, adjustment, and maintenance of this equipment.

**Do not perform work on the unit while wearing loose clothing, jewelry or without eye protection.**

Failure to comply could result in death or serious injury.

Remove all metal objects such as watches and rings, secure loose clothing, and wear eye protection before beginning work on the unit.

**Do not touch any terminals before the capacitors have fully discharged.**

Failure to comply could result in death or serious injury.

Before servicing, disconnect all power to the equipment. The internal capacitor remains charged even after the power supply is turned off. The charge indicator LED will extinguish when the DC bus voltage is below 50 Vdc. To prevent electric shock, wait for at least the time specified on the warning label; after all indicators are OFF, measure the voltage level to confirm it has reached a safe level.

#### Fire Hazard

**Tighten all terminal screws to the specified tightening torque.**

Loose electrical connections could result in death or serious injury by fire due to overheating of electrical connections.

**Do not use an improper voltage source.**

Failure to comply could result in death or serious injury by fire.

Verify that the rated voltage of the unit matches the voltage of the incoming power supply before applying power.

**Do not use improper combustible materials.**

Failure to comply could result in death or serious injury by fire.

Attach the unit to metal or other noncombustible material.

**NOTICE****Observe proper electrostatic discharge procedures (ESD) when handling the unit and circuit boards.**

Failure to comply may result in ESD damage to the unit circuitry.

**Follow cooling fan replacement instructions. The cooling fan cannot operate properly when it is installed incorrectly and could seriously damage the unit.**

Follow the instructions in this manual to replace the cooling fan, making sure that the label is on top before inserting the cooling fan into the unit. To ensure maximum useful product life, replace all cooling fans when performing maintenance.

**Do not use unshielded cable for control wiring.**

Failure to comply may cause electrical interference resulting in poor system performance. Use shielded, twisted-pair wires and ground the shield to the shield ground terminal E (G) of the unit.

**Do not modify the unit circuitry.**

Failure to comply could result in damage to the unit and will void warranty.

Yaskawa is not responsible for any modification of the product made by the user. This product must not be modified.

**Check all the wiring to ensure that all connections are correct after installing the unit and connecting any other devices.**

Failure to comply could result in damage to the unit.

**Frequently switching the unit power supply on and off can damage the unit.**

To get the full performance life out of the electrolytic capacitors and circuit relays, refrain from switching the unit power supply off and on more than once every 30 minutes.

**Do not operate damaged equipment.**

Failure to comply could result in further damage to the equipment.

Do not connect or operate any equipment with visible damage or missing parts.

## 6.2 Inspection

Power electronics have limited life and may exhibit changes in characteristics or performance deterioration after years of use under normal conditions. To help avoid such problems, it is important to perform preventive maintenance and periodic inspection on the regenerative unit.

Regenerative units contain a variety of power electronics such as power transistors, semiconductors, capacitors, resistors, fans, and relays. The electronics in the regenerative unit serve a critical role in maintaining proper motor control.

Follow the inspection lists provided in this chapter as a part of a regular maintenance program.

**Note:** The regenerative unit will require more frequent inspection if it is placed in harsh environments, such as:

- High ambient temperatures
- Frequent starting and stopping
- Fluctuations in the AC supply or load
- Excessive vibrations or shock loading
- Dust, metal dust, salt, sulfuric acid, chlorine atmospheres
- Poor storage conditions

Perform the first equipment inspection one to two years after installation.

### ◆ Recommended Daily Inspection

**Table 6.1** outlines the recommended daily inspection for the Yaskawa regenerative unit. Check the following items on a daily basis to avoid premature deterioration in performance or product failure. Copy this checklist and mark the “Checked” column after each inspection.

**NOTICE:** Check the operation of the cooling fan only during inspections.

**Table 6.1 General Recommended Daily Inspection Checklist**

Inspection Category	Inspection Points	Corrective Action	Checked
Cooling	Inspect for abnormal heat generated from the regenerative unit and visible discoloration.	Check for the following: <ul style="list-style-type: none"> <li>• Excessive load.</li> <li>• Dirty heatsink.</li> <li>• Tighten all loose screws.</li> <li>• Ambient temperature.</li> </ul>	
	Inspect regenerative unit cooling fan and circulation fan operation	Check for the following: <ul style="list-style-type: none"> <li>• Clogged or dirty fan.</li> <li>• Correct Fan operation parameter setting. Refer to <b>o: Operator-Related Settings on page 151</b> for details.</li> </ul>	
Environment	Verify the regenerative unit environment complies with the specifications listed in <b>Installation Environment on page 21</b> .	Eliminate the source of contaminants or correct poor environment.	
Power Supply Voltage	Check main power supply and control voltages.	<ul style="list-style-type: none"> <li>• Correct the voltage or power supply to within nameplate specifications.</li> <li>• Verify all main circuit phases.</li> </ul>	

### ◆ Recommended Periodic Inspection

**Table 6.2** outlines the recommended periodic inspections for Yaskawa regenerative unit installations. Although periodic inspections should generally be performed once a year, the regenerative unit may require more frequent inspection in harsh environments or with rigorous use. Operating and environmental conditions, along with experience in each application, will determine the actual inspection frequency for each installation. Periodic inspection will help to avoid premature deterioration in performance or product failure. Copy this checklist and mark the “Checked” column after each inspection.

## ■ Periodic Inspection

**DANGER!** *Electrical Shock Hazard. Do not inspect, connect, or disconnect any wiring while the power is on. Failure to comply can result in serious personal injury. Before servicing, disconnect all power to the equipment. The internal capacitor remains charged even after the power supply is turned off. The charge indicator LED will extinguish when the DC bus voltage is below 50 Vdc. To prevent electric shock, wait for at least the time specified on the warning label; after all indicators are OFF, measure for unsafe voltages to confirm the regenerative unit is safe prior to servicing.*

**NOTICE:** *Check the operation of the cooling fan only during inspections.*

**Table 6.2 Periodic Inspection Checklist**

Inspection Area	Inspection Points	Corrective Action	Checked
<b>Main Circuit Periodic Inspection</b>			
<b>General</b>	<ul style="list-style-type: none"> <li>Inspect equipment for discoloration from overheating or deterioration.</li> <li>Inspect for damaged or deformed parts.</li> </ul>	<ul style="list-style-type: none"> <li>Replace damaged components as required.</li> <li>The regenerative unit has few serviceable parts and may require complete regenerative unit replacement.</li> </ul>	
	Inspect for dirt, foreign particles, or dust collection on components.	<ul style="list-style-type: none"> <li>Inspect enclosure door seal if used.</li> <li>Use a vacuum cleaner to remove dust and dirt, but do not allow it to come into contact with product components.</li> <li>Replace components if cleaning is not possible.</li> </ul>	
<b>Conductors and Wiring</b>	<ul style="list-style-type: none"> <li>Inspect wiring and connections for discoloration, damage, or heat stress.</li> <li>Inspect wire insulation and shielding for wear.</li> </ul>	Repair or replace damaged wiring.	
<b>Terminals</b>	Inspect terminals for stripped, damaged, or loose connections.	Tighten loose screws and replace damaged screws or terminals.	
<b>Relays and Contactors</b>	<ul style="list-style-type: none"> <li>Inspect contactors and relays for excessive noise during operation.</li> <li>Inspect coils for signs of overheating such as melted or cracked insulation.</li> </ul>	<ul style="list-style-type: none"> <li>Check coil voltage for overvoltage or undervoltage conditions.</li> <li>Replace damaged removable relays, contactors, or circuit board.</li> </ul>	
<b>Electrolytic Capacitor</b>	<ul style="list-style-type: none"> <li>Inspect for leaking, discoloration, or cracks.</li> <li>Check if the cap has come off, for any swelling, or if the sides have burst open.</li> </ul>	The regenerative unit has few serviceable parts and may require complete regenerative unit replacement.	
<b>Diode, IGBT (Power Transistor)</b>	Inspect for dust or other foreign material collected on the surface.	Use a vacuum cleaner to remove dust and dirt, but do not allow it to come into contact with product components.	
<b>Control Circuit Periodic Inspection</b>			
<b>General</b>	<ul style="list-style-type: none"> <li>Inspect terminals for stripped, damaged, or loose connections.</li> <li>Make sure all terminals have been properly tightened.</li> </ul>	<ul style="list-style-type: none"> <li>Tighten loose screws and replace damaged screws or terminals.</li> <li>If terminals are integral to a circuit board, then board or regenerative unit replacement may be required.</li> </ul>	
<b>Circuit Boards</b>	Check for any odor, discoloration, and rust. Make sure connections are properly fastened and that no dust or oil mist has accumulated on the surface of the board.	<ul style="list-style-type: none"> <li>Fix any loose connections.</li> <li>If an antistatic cloth or vacuum plunger cannot be used, replace the board.</li> <li>Use a vacuum cleaner to remove dust and dirt, but do not allow it to come into contact with product components.</li> <li>Do not use any solvents to clean the board.</li> <li>The regenerative unit has few serviceable parts and may require complete regenerative unit replacement.</li> </ul>	
<b>Cooling System Periodic Inspection</b>			
<b>Cooling Fan, Circulation Fan, Control Board Cooling Fan</b>	<ul style="list-style-type: none"> <li>Check for abnormal oscillation or unusual noise.</li> <li>Check for damaged or missing fan blades.</li> </ul>	<ul style="list-style-type: none"> <li>Replace as required.</li> <li><b>Cooling Fans on page 108</b> for information on cleaning or replacing the fan.</li> </ul>	
<b>Heatsink</b>	Inspect for dust or other foreign material collected on the surface.	Use a vacuum cleaner to remove dust and dirt, but do not allow it to come into contact with product components.	
<b>Display Periodic Inspection</b>			
<b>Digital Operator</b>	<ul style="list-style-type: none"> <li>Make sure data appears on the display properly.</li> <li>Inspect for dust or other foreign material that may have collected on surrounding components.</li> </ul>	<ul style="list-style-type: none"> <li>Contact the nearest sales office if there is any trouble with the display or keypad.</li> <li>Clean the digital operator.</li> </ul>	

## 6.3 Periodic Maintenance

The regenerative unit has Maintenance Monitors that keep track of component wear. This feature provides advance maintenance warning and eliminates the need to shut down the entire system for unexpected problems. The regenerative unit allows the user to check predicted maintenance periods for the components listed below.

- Cooling Fan, Circulation Fan, Control Board Cooling Fan
- Electrolytic Capacitors
- Inrush Prevention Circuit

For replacement parts, contact the distributor where the regenerative unit was purchased or contact Yaskawa directly.

### ◆ Replacement Parts

**Table 6.3** contains the estimated performance life of components that require replacement during the life of the regenerative unit. Only use Yaskawa replacement parts for the appropriate model and revision.

**Table 6.3 Estimated Performance Life**

Component	Estimated Performance Life
Cooling Fan, Circulation, Control Board Cooling Fan	10 years
Electrolytic Capacitors	10 years <1>
Fuse	10 years

<1> The regenerative unit has few serviceable parts and may require complete regenerative unit replacement.

**NOTICE:** *Estimated performance life based on specific usage conditions. These conditions are provided for the purpose of replacing parts to maintain performance. Some parts may require more frequent replacement due to poor environments or rigorous use.*

*Usage conditions for estimated performance life:*

*Ambient temperature: Yearly average of 40°C (IP00/Open Type enclosure)*

*Load factor: 80% maximum*

*Operation time: 24 hours a day*

### ■ Performance Life Monitors Maintenance Monitors

The regenerative unit calculates the maintenance period for components that may require replacement during the life of the regenerative unit. A percentage of the maintenance period is displayed on the digital operator by viewing the appropriate monitor parameter.

When the maintenance period reaches 100%, there is increased risk that the regenerative unit may malfunction. Yaskawa recommends checking the maintenance period regularly to ensure maximum performance life.

Refer to **Inspection on page 104** for more details.

**Table 6.4 Performance Life Monitors Used for Component Replacement**

Parameter	Component	Contents
U4-03	Cooling Fan	Displays the accumulated operation time of the fan from 0 to 99999 hours. This value is automatically reset to 0 after it reaches 99999.
U4-04	Circulation Fan Control Board Cooling Fan	
U4-05	DC Bus Capacitors	Displays the accumulated time the capacitors are used as a percentage of the specified maintenance period.
U4-06	Inrush (pre-charge) Relay	Displays the number of times the regenerative unit is powered up as a percentage of the performance life of the inrush circuit.

### ■ Alarm Outputs for Maintenance Monitors

An output can be set up to inform the user when a specific components has neared its expected performance life.

When one of multi-function relay output terminals has been assigned the maintenance monitor function (H2-□□ = 2F), the terminal will close when the cooling fan, DC bus capacitors, or DC bus pre-charge relay reach 90% of the expected performance life. Additionally the digital operator will display an alarm like shown in [Table 6.5](#) to indicate the specific components that may need maintenance.

**Table 6.5 Maintenance Alarms (H2-01 to H2-03 = 2F)**

Digital Operator Alarm Display		Function	Corrective Action
LT-1	LT-1	The cooling fans, the DC bus capacitors, or the DC bus charge circuit have reached 90% of their designated life time	Replace the cooling fan.
LT-2	LT-2		Contact a Yaskawa representative or the nearest Yaskawa sales office on possible regenerative unit replacement.
LT-3	LT-3		Contact a Yaskawa representative or the nearest Yaskawa sales office on possible regenerative unit replacement.

### ■ Related Parameters

**NOTICE:** Use parameters o4-03, o4-05, and o4-07 to reset a Maintenance Monitor to zero after replacing a specific component. If these parameters are not reset after the corresponding parts have been replaced, the Maintenance Monitor function will continue to count down the performance life from the value that was reached with the old part.

**Table 6.6 Maintenance Setting Parameters**

No.	Name	Function
o4-03 <1><2>	Cooling Fan Operation Time Setting	Sets the value of the fan operation time monitor U4-03 in units of 10 h.
o4-05 <2>	Capacitor Maintenance Setting	Sets the value of the Maintenance Monitor for the capacitors.
o4-07 <2>	DC Bus Pre-Charge Relay Maintenance Setting	Sets the value of the Maintenance Monitor for the soft charge bypass relay.

<1> Parameter o4-03 is set in increments of 10 hours. For example, setting o4-03 to 30 set the operating time for cooling fan maintenance 300 hours and the Cooling Fan Operation Time monitor (U4-03) will show 300 hours.

<2> The maintenance period depends on the operating environment of the regenerative unit.

## 6.4 Cooling Fans

**NOTICE:** Follow cooling fan replacement instructions. The cooling fan cannot operate properly when installed incorrectly and could seriously damage the regenerative unit. To ensure maximum useful product life, replace all cooling fans when performing maintenance.

Contact a Yaskawa representative or the nearest Yaskawa sales office to order replacement cooling fans as required.

For regenerative units with multiple cooling fans, replace all the fans when performing maintenance to ensure maximum product performance life.

**WARNING!** *Electrical Shock Hazard.* Do not connect or disconnect wiring while the power is on. Failure to comply can result in serious personal injury. Before servicing the regenerative unit, disconnect all power to the equipment. The internal capacitor remains charged even after the power supply is turned off. After shutting off the power, wait for at least the amount of time specified on the regenerative unit before touching any components.

**CAUTION!** *Burn Hazard.* Do not touch a hot regenerative unit heatsink. Failure to comply could result in minor or moderate injury. Shut off the power to the regenerative unit when replacing the cooling fan. To prevent burns, wait at least 15 minutes and ensure the heatsink has cooled down.

**NOTICE:** Follow cooling fan replacement instructions. Improper fan replacement could cause damage to equipment. Make sure the fan is facing upwards when installing the replacement fan into the regenerative unit. Replace all fans when performing maintenance to help ensure maximum useful product life.

### ◆ Number of Cooling Fans

Three-Phase 200 V Class				Three-Phase 400 V Class			
Model	Cooling Fans	Circulation Fans	Page	Model	Cooling Fans	Circulation Fans	Page
2A03P5	2	–	110	4A03P5	2	–	110
2A0005	2	–		4A0005	2	–	
2A0007	2	–		4A0007	2	–	
2A0010	2	–		4A0010	2	–	
2A0014	2	–		4A0014	2	–	
2A0017	2	–		4A0017	2	–	
2A0020	2	–		4A0020	2	–	
2A0028	2	–		4A0028	2	–	
2A0035	2	–	112	4A0035	2	–	112
2A0053	2	–	114	4A0043	2	–	114
2A0073	2	–		4A0053	2	–	
2A0105	2	1		4A0073	2	–	
				4A0105	2	–	
				4A0150	2	–	
				4A0210	3	1	
				4A0300	3	1	



## ◆ Cooling Fan Component Names

**WARNING!** *Electrical Shock Hazard. Do not connect or disconnect wiring while the power is on. Failure to comply can result in serious personal injury. Before servicing the regenerative unit, disconnect all power to the equipment. The internal capacitor remains charged even after the power supply is turned off. After shutting off the power, wait for at least the amount of time specified on the regenerative unit before touching any components.*

**CAUTION!** *Burn Hazard. Do not touch a hot regenerative unit heatsink. Failure to comply could result in minor or moderate injury. Shut off the power to the regenerative unit when replacing the cooling fan. To prevent burns, wait at least 15 minutes and ensure the heatsink has cooled down.*

2A03P5 to 2A0028  
4A03P5 to 4A0028

2A0035  
4A0035, 4A0043

2A0053 to 2A0073  
4A0053 to 4A0105

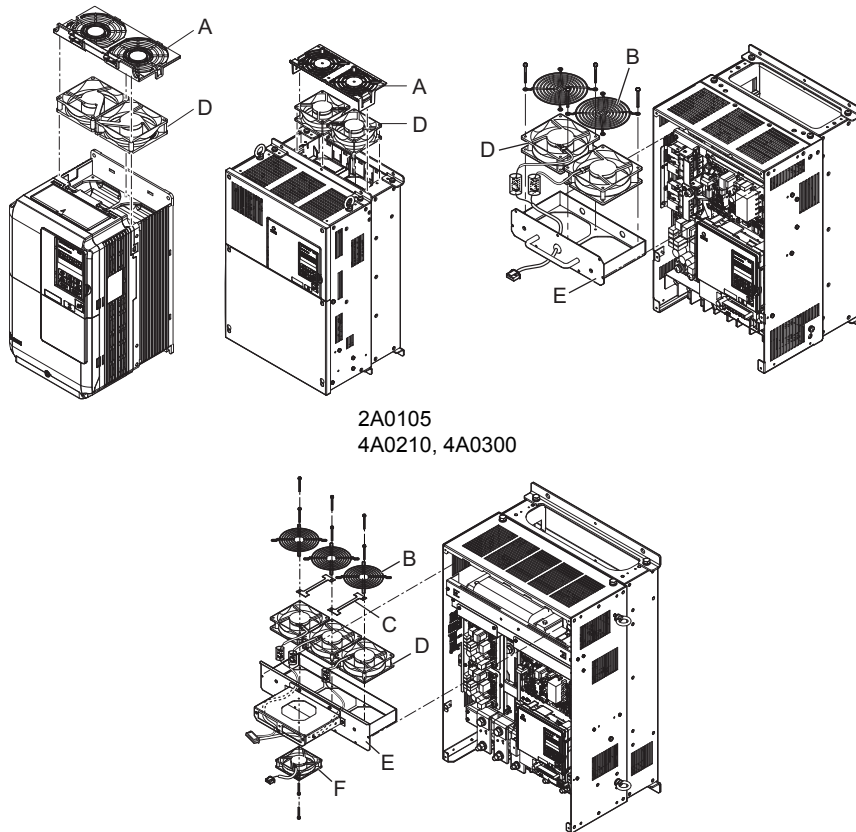

2A0105  
4A0210, 4A0300

A – Fan finger guard  
B – Fan guard  
C – Cable cover

D – Cooling fan  
E – Fan bracket  
F – Circulation fan

Figure 6.1 Cooling Fan Component Names (2A03P5 to 2A0105, 4A03P5 to 4A0300)

### ◆ Cooling Fan Replacement

**WARNING! Electrical Shock Hazard.** Do not connect or disconnect wiring while the power is on. Failure to comply can result in serious personal injury. Before servicing the regenerative unit, disconnect all power to the equipment. The internal capacitor remains charged even after the power supply is turned off. After shutting off the power, wait for at least the amount of time specified on the regenerative unit before touching any components.

**CAUTION! Burn Hazard.** Do not touch a hot regenerative unit heatsink. Failure to comply could result in minor or moderate injury. Shut off the power to the regenerative unit when replacing the cooling fan. To prevent burns, wait at least 15 minutes and ensure the heatsink has cooled down.

**NOTICE:** Follow cooling fan replacement instructions. Improper fan replacement could cause damage to equipment. Make sure the fan is facing upwards when installing the replacement fan into the regenerative unit. Replace all fans when performing maintenance to help ensure maximum useful product life.

#### ■ 2A03P5 to 2A0028, 4A03P5 to 4A0028

##### Removing the Cooling Fan Finger Guard and Cooling Fan

1. Depress the right and left sides of the fan cover tabs and pull upward. Remove the fan cover from the top of the regenerative unit. The following figure illustrates a regenerative unit with a single cooling fan.

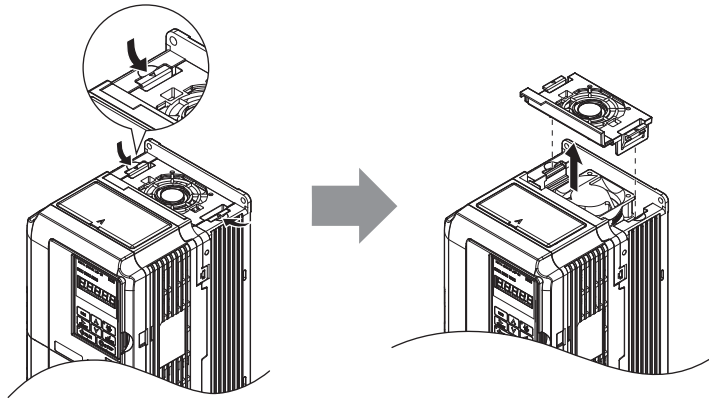

Figure 6.2 Remove the Cooling Fan Finger Guard: 2A03P5 to 2A0028, 4A03P5 to 4A0028

2. Remove the cooling fan cartridge. Disconnect the pluggable connector and remove the fan.

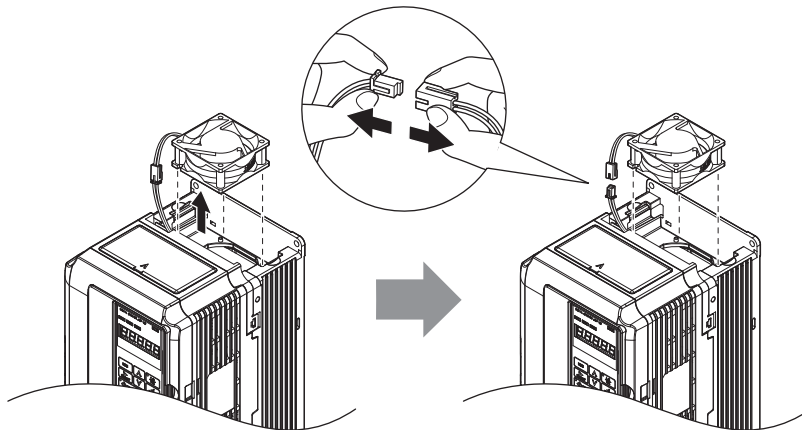
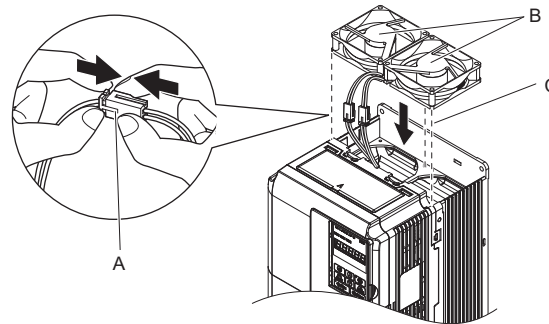

Figure 6.3 Remove the Cooling Fan: 2A03P5 to 2A0028, 4A03P5 to 4A0028

### Installing the Cooling Fan

Reverse the procedure described above to reinstall the cooling fan.

1. Install the replacement cooling fan into the regenerative unit, ensuring the alignment pins line up as shown in the figure below.



**A** – Push the connectors together so no space remains between them

**C** – Make sure the alignment pins line up properly

**B** – Label facing up

**Figure 6.4 Install the Cooling Fan: 2A03P5 to 2A0028, 4A03P5 to 4A0028**

2. Properly connect the fan power lines, then place the cable back into the recess of the regenerative unit.

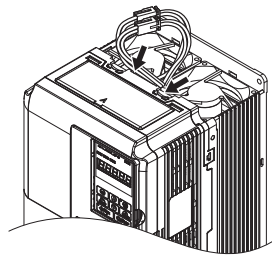

**Figure 6.5 Connect the Cooling Fan Power Supply Connectors: 2A03P5 to 2A0028, 4A03P5 to 4A0028**

3. While pressing in on the hooks on the front side of the fan finger guard, guide the fan finger guard until it clicks back into place.

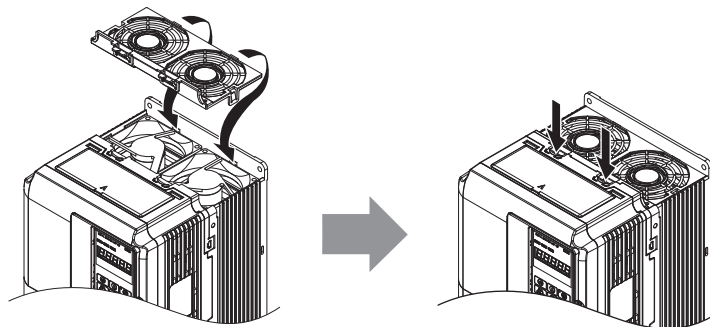

**Figure 6.6 Reattach the Fan Finger Guard: 2A03P5 to 2A0028, 4A03P5 to 4A0028**

4. Turn on the power supply and set o4-03 to 0 to reset the Maintenance Monitor cooling fan operation time.

### ■ 2A0035, 4A0035, 4A0043

#### Removing the Cooling Fan Finger Guard and Cooling Fan

1. While pressing in on the hooks located on the left and right sides of the fan finger guard, free the fan finger guard leading by lifting the back end first.

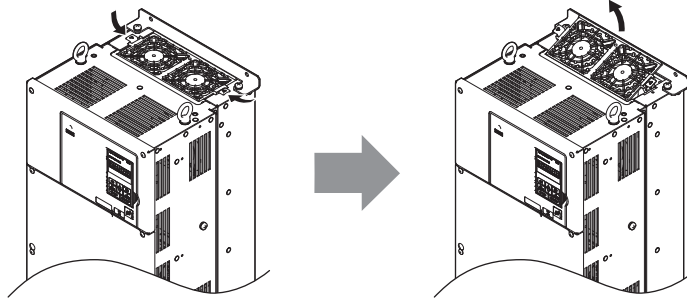

Figure 6.7 Remove the Cooling Fan Finger Guard: 2A0035, 4A0035, 4A0043

2. Lift out the back end of the fan finger guard first. Unplug the replay connector and free the fan finger guard from the regenerative unit.

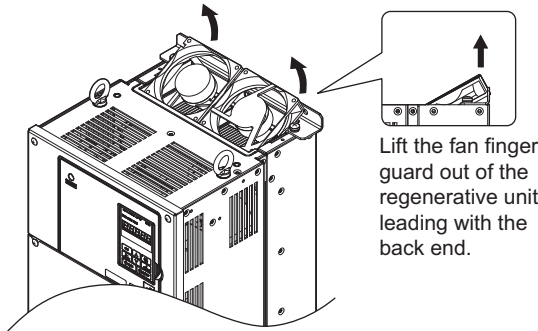

Figure 6.8 Remove the Cooling Fan: 2A0035, 4A0035, 4A0043

#### Installing the Cooling Fan

Reverse the procedure described above to reinstall the cooling fan.

1. Properly connect the fan power lines.
2. Place the power supply connectors and cable back into the recess of the regenerative unit.

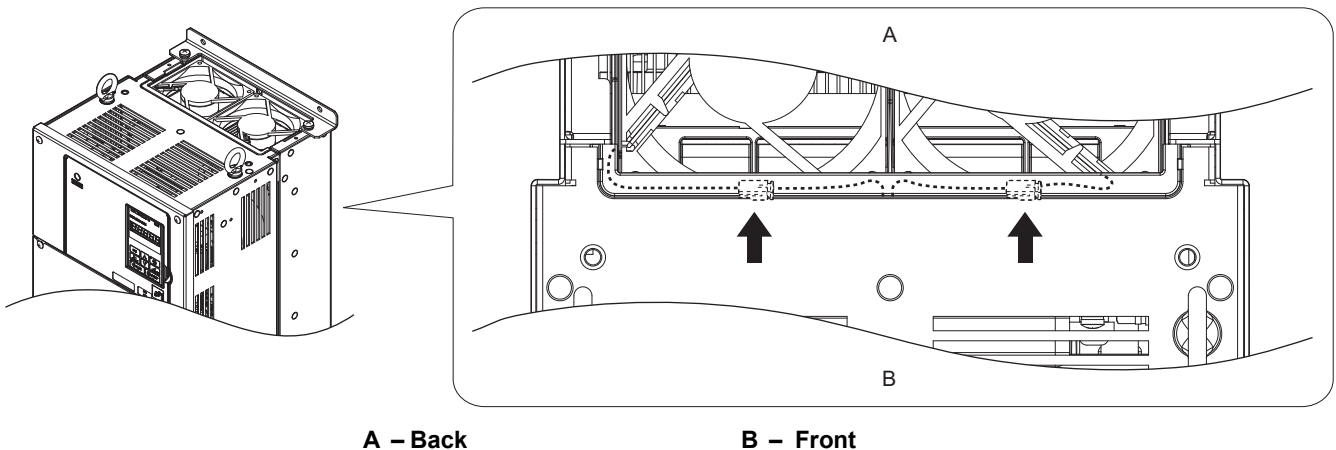
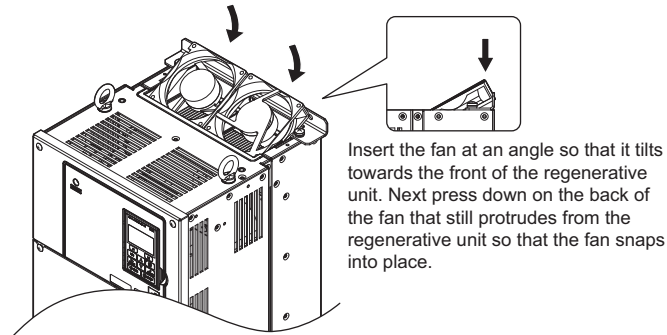

Figure 6.9 Cooling Fan Power Supply Connectors: 2A0035, 4A0035, 4A0043

3. Install the replacement fan into the regenerative unit.



**Figure 6.10 Install the Cooling Fan: 2A0035, 4A0035, 4A0043**

4. Tilt up the back end of the fan finger guard and slide the fan finger guard into the opening near the front of the regenerative unit, then guide the fan finger guard into place.

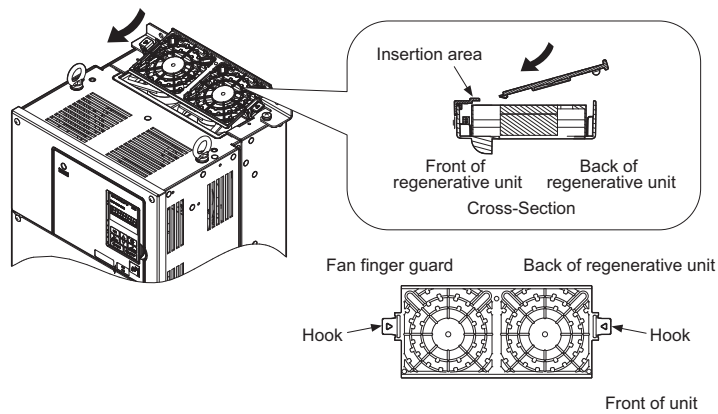

**Figure 6.11 Reattach the Fan Cover: 2A0035, 4A0035, 4A0043**

5. Press in on the hooks of the left and right sides of the fan cover and guide the fan finger guard until it clicks into place.

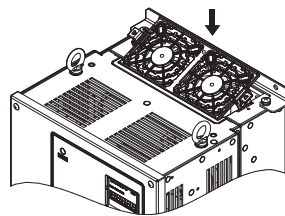

**Figure 6.12 Reattach the Fan Finger Guard: 2A0035, 4A0035, 4A0043**

6. Turn on the power supply and set o4-03 to 0 to reset the Maintenance Monitor cooling fan operation time.

## 6.4 Cooling Fans

### ■ 2A0053 to 2A0105, 4A0053 to 4A0300

#### Removing and Disassembling the Cooling Fan Unit

1. Remove the terminal cover and front cover. Refer to [Terminal Cover on page 38](#) for details.
2. Remove the fan connector (CN6). Remove the fan connectors (CN6, CN7) in models 2A0105, 4A0210, and 4A0300.

2A0053, 2A0073, 4A0053 to 4A0150

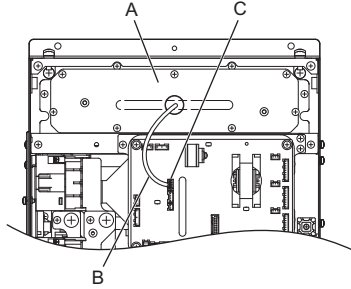

A – Fan unit  
B – Fan relay cable  
C – Fan connector (CN6)

2A0105, 4A0210, 4A0300

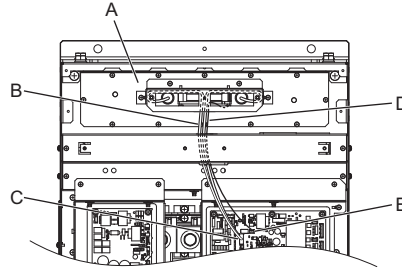

D – Circulation fan relay cable  
E – Fan connector (CN7)

Figure 6.13 Cooling Fan Replacement: Fan Unit and Connectors

3. Remove the screws holding the fan unit in place and slide the fan unit out of the regenerative unit.

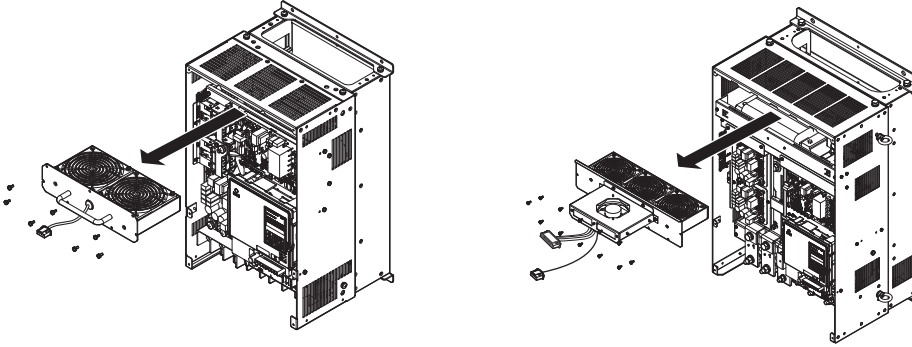

Figure 6.14 Remove the Fan Unit

4. Remove the fan guard and replace the cooling fans.

- Note:** 1. Do not pinch the fan cable between parts when reassembling the fan unit.  
 2. Install the internal circulation fans so that they blow air upward. Install the cooling fan so that it blows air downward.

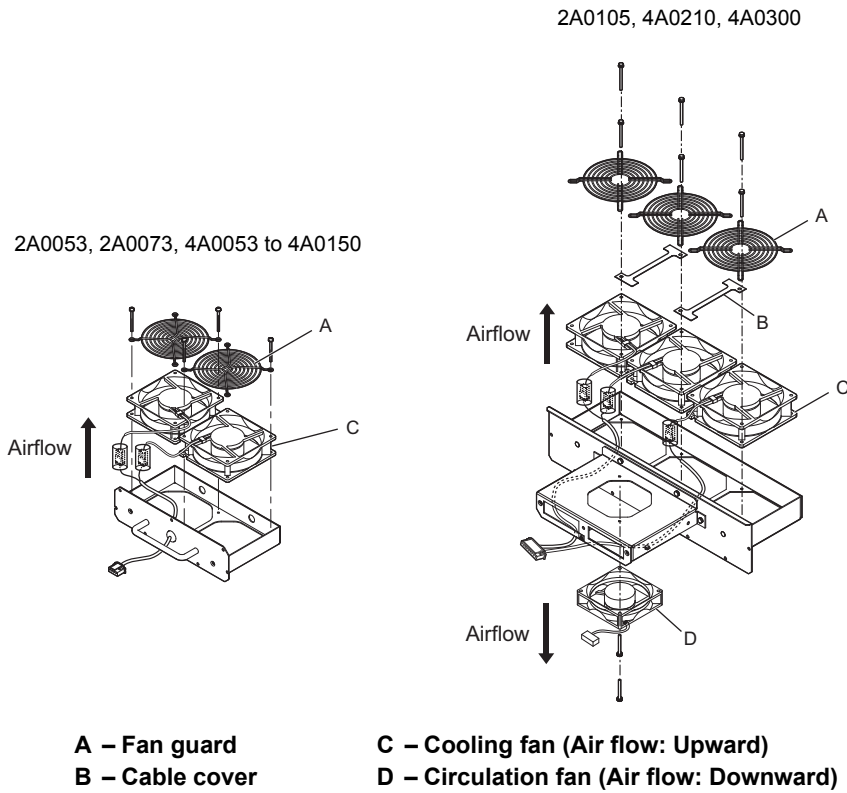
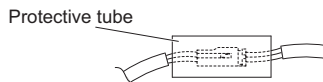

Figure 6.15 Fan Unit Disassembly

**Cooling Fan Wiring: 2A0053, 4A0053, 4A0073**

1. Position the protective tube so the fan connector sits in the center of the protective tube.



2. Place the fan connector covered by the tube.

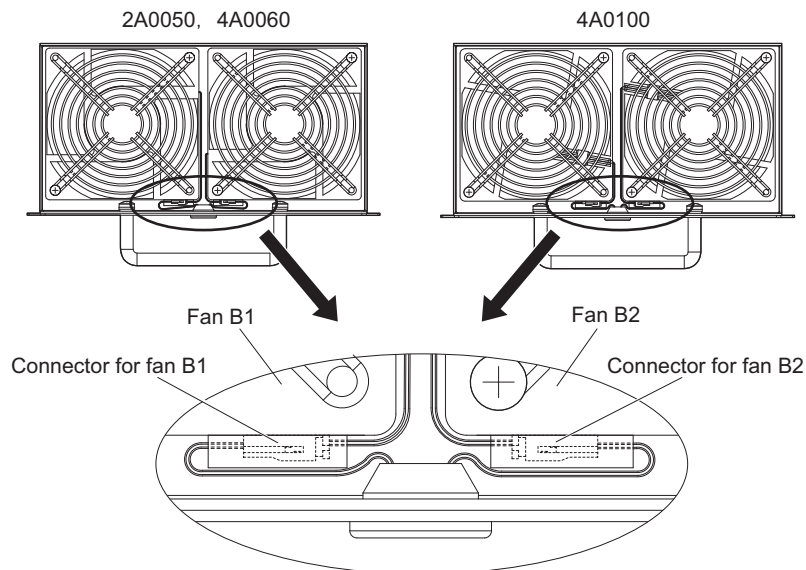

Figure 6.16 Cooling Fan Wiring: 2A0053, 4A0053, 4A0073

3. Make sure that the protective tube does not stick out beyond the fan guard.



## 6.4 Cooling Fans

### Cooling Fan Wiring: 2A0073, 4A0105, 4A0150

1. Position the protective tube so the fan connector sits in the center of the protective tube.

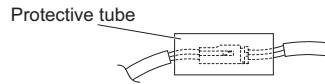

2. Insert the connector for fan B2 and guide the lead wire for fan B2 so the cable hook holds it in place. Insert the connector for fan B1.

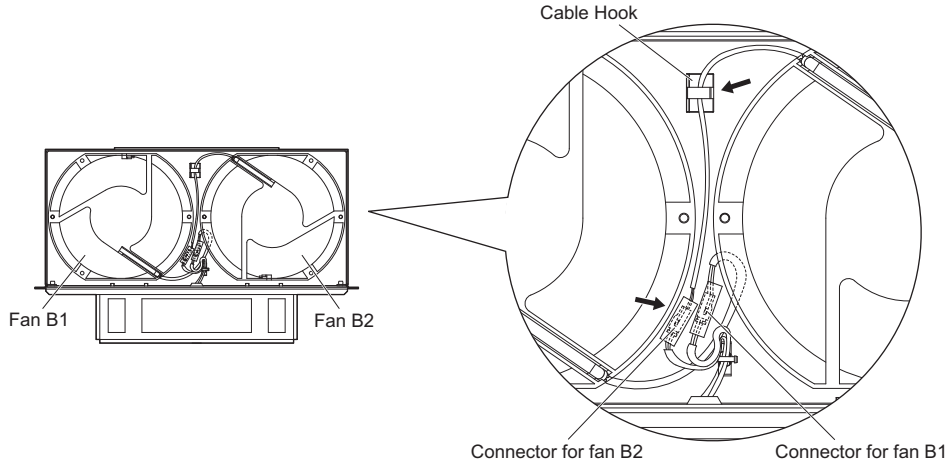
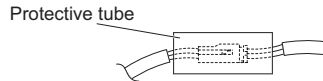

Figure 6.17 Cooling Fan Wiring: 2A0073, 4A0105, 4A0150

3. Double-check the relay connector to ensure it is properly connected.

### Cooling Fan Wiring: 2A0105, 4A0210 to 4A0300

1. Position the protective tube so the fan connector sits in the center of the protective tube.



2. In the space between fans 1 and 2, place the fan connector for fan B2 in front of the fan connector for fan B1.

3. Place the connector for fan B3 between fans B2 and B3.

**Note:** Model 2A0105 does not have the fan B3.

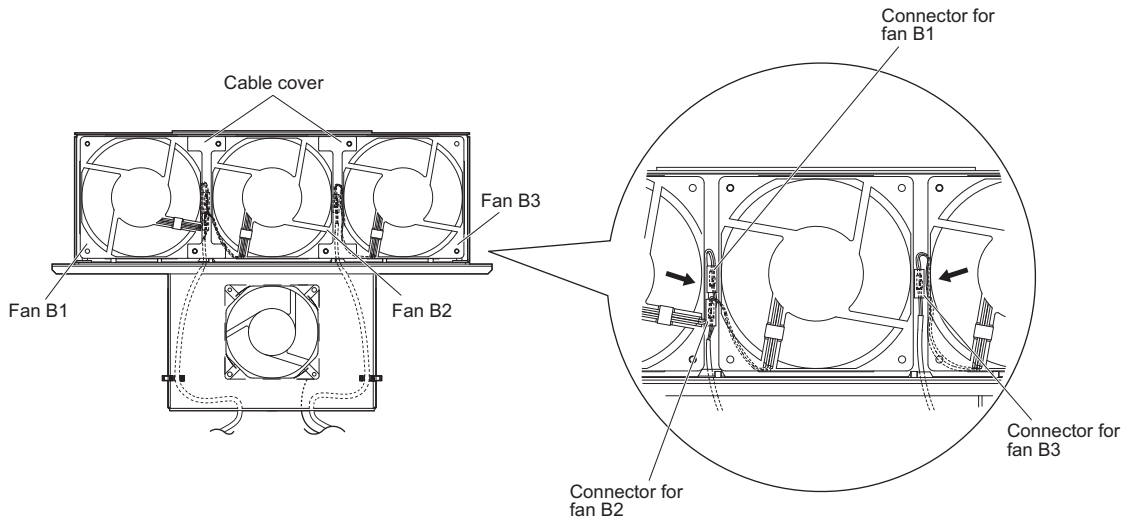

Figure 6.18 Cooling Fan Wiring: 2A0053 to 2A0105, 4A0053 to 4A0300



4. Double-check the relay connector to ensure it is properly connected.
5. Reattach the cable cover to its original position and tighten the screws so the fan guard holds the cable cover in place.

**Note:** Do not pinch the fan cable between parts when reassembling the fan unit.

### Installing the Cooling Fan Unit

1. Reverse the procedure described above to reinstall the cooling fan unit.

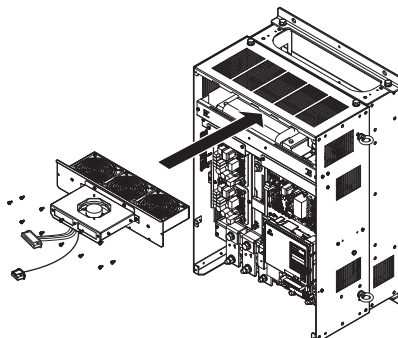

**Figure 6.19 Install the Cooling Fan Unit: 2A0053 to 2A0105, 4A0053 to 4A0300**

2. Reattach the covers and digital operator.
3. Turn on the power supply and set o4-03 to 0 to reset the Maintenance Monitor cooling fan operation time.

# 6.5 Regenerative Unit Replacement

### ◆ Serviceable Parts

The regenerative unit contains some serviceable parts. The following parts can be replaced over the life span of the regenerative unit:

- Terminal board I/O PCBs
- Cooling fan(s)
- Front cover

Replace the regenerative unit if the main power circuitry is damaged. Contact your local Yaskawa representative before replacing parts if the regenerative unit is still under warranty. Yaskawa reserves the right to replace or repair the regenerative unit according to Yaskawa warranty policy.

**WARNING! Electrical Shock Hazard.** Do not inspect, connect, or disconnect any wiring while the power is on. Failure to comply can result in serious personal injury. Before servicing the regenerative unit, disconnect all power to the equipment. The internal capacitor remains charged even after the power supply is turned off. After shutting off the power, wait for at least the amount of time specified on the regenerative unit before touching any components.

### ◆ Terminal Board

The regenerative unit has a modular I/O terminal block that facilitates quick regenerative unit replacement. The terminal board contains on-board memory that stores all regenerative unit parameter settings and allows the parameters to be saved and transferred to the replacement regenerative unit. To transfer the terminal board, disconnect the terminal board from the damaged regenerative unit and reconnect it to the replacement regenerative unit. There is no need to manually reprogram the replacement regenerative unit after transferring the terminal board.

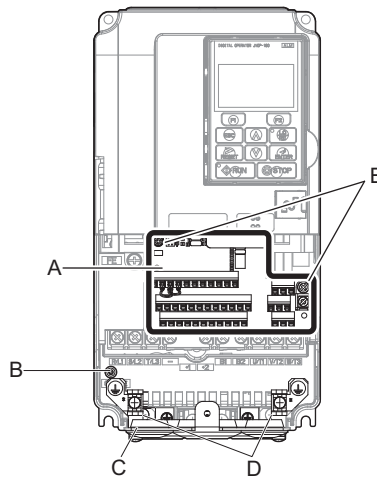

- A – Removable terminal board
- B – Charge LED
- C – Bottom cover

- D – Bottom cover screws
- E – Terminal board locking screws

Figure 6.20 Terminal Board

## ◆ Replacing the Regenerative Unit

**WARNING!** *Electrical Shock Hazard. Do not connect or disconnect wiring while the power is on. Failure to comply can result in serious personal injury. Before servicing the regenerative unit, disconnect all power to the equipment. The internal capacitor remains charged even after the power supply is turned off. After shutting off the power, wait for at least the amount of time specified on the regenerative unit before touching any components.*

**WARNING!** *Electrical Shock Hazard. Do not allow unqualified personnel to perform work on the regenerative unit. Failure to comply could result in serious injury. Installation, maintenance, inspection and servicing must be performed only by authorized personnel familiar with installation, adjustment and maintenance of regenerative units.*

**NOTICE:** *Observe proper electrostatic discharge procedures (ESD) when handling the regenerative unit and circuit boards. Failure to comply may result in ESD damage to the regenerative unit circuitry.*

The following procedure explains how to replace a regenerative unit.

This section provides instructions for regenerative unit replacement only.

To install option boards or other types of options, refer to the specific manuals for those options.

### ■ Removing the Regenerative Unit

1. Remove the terminal cover.

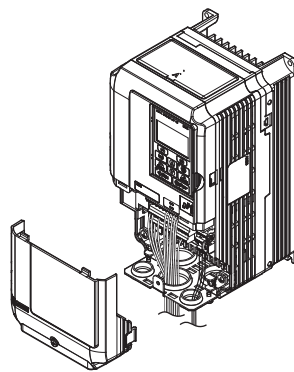

Figure 6.21 Removing the Terminal Cover

2. Loosen the screws holding the terminal board in place. Remove the screw securing the bottom cover and remove the bottom cover from the regenerative unit.

**Note:** IP00/Open Type enclosure regenerative units do not have a bottom cover or conduit.

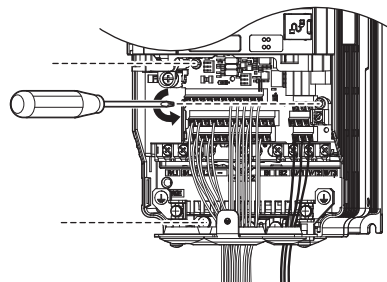

Figure 6.22 Unscrew the Terminal Board and Remove the Terminal Cover

## 6.5 Regenerative Unit Replacement

- Slide the terminal board as illustrated by the arrows to remove it from the regenerative unit along with the bottom cover.

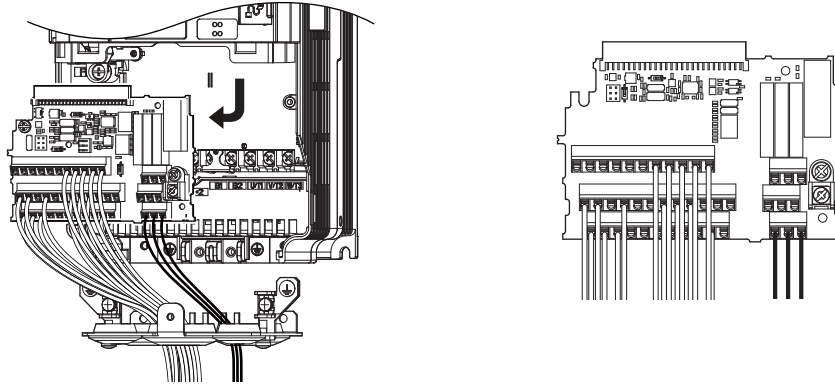

Figure 6.23 Remove the Terminal Board and Disconnected Removable Terminal Board

- Disconnect all option cards and options. Make sure they are intact before reusing them.
- Replace the regenerative unit and wire the main circuit.

### ■ Installing the Regenerative Unit

- After wiring the main circuit, connect the terminal block to the regenerative unit as shown in [Figure 6.24](#). Use the installation screw to fasten the terminal block into place.

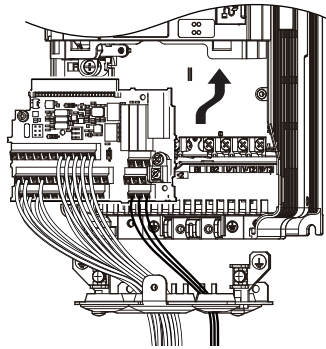

Figure 6.24 Installing the Terminal Board

- Replace the terminal cover.
- Put the terminal cover back into its original place.
- When the power to the regenerative unit is first switched on, all parameter settings are transferred from the terminal board into the regenerative unit memory. Should an oPE04 error occur, load the parameter settings that have been saved on the terminal board onto the new regenerative unit by setting parameter A1-03 to 5550. Reset timers used for the Maintenance Monitor function by setting parameters o4-01 through o4-12 back to 0, and parameter o4-13 to 1.

# Standard Configuration Devices, Peripheral Devices, and Options

---

This chapter explains the installation of peripheral devices and options available for the regenerative unit.

<b>7.1</b>	<b>SECTION SAFETY</b> .....	<b>122</b>
<b>7.2</b>	<b>REGENERATIVE UNIT OPTIONS AND PERIPHERAL DEVICES</b> .....	<b>124</b>
<b>7.3</b>	<b>CONNECTING STANDARD CONFIGURATION DEVICES AND PERIPHERAL DEVICES</b> .....	<b>125</b>
<b>7.4</b>	<b>STANDARD CONFIGURATION DEVICES WIRING</b> .....	<b>126</b>
<b>7.5</b>	<b>INSTALLING PERIPHERAL DEVICES</b> .....	<b>130</b>

## 7.1 Section Safety

### WARNING

#### Electrical Shock Hazard

**Do not connect or disconnect wiring while the power is on.**

Failure to comply could result in death or serious injury.

Before servicing, disconnect all power to the equipment. The internal capacitor remains charged even after the power supply is turned off. The charge indicator LED will extinguish when the DC bus voltage is below 50 Vdc. To prevent electric shock, wait for at least the time specified on the warning label; after all indicators are OFF, measure for unsafe voltages to confirm the unit is safe prior to servicing.

**Do not operate equipment with covers removed.**

Failure to comply could result in death or serious injury.

The diagrams in this section may show units without covers or safety shields to show details. Be sure to reinstall covers or shields before operating the unit and run the unit according to the instructions described in this manual.

**Do not remove covers or touch circuit boards while the power is on.**

Failure to comply could result in death or serious injury.

**If a fuse is open or residual current monitoring/detection (RCM or RCD) is tripped, check the wiring and the selection of the peripheral devices.**

Contact your supplier if the cause cannot be identified. Failure to comply may result in electrical shock by indirect or direct contact. The regenerative unit can cause a residual current with a DC component in the protective earthing conductor.

**Do not allow unqualified personnel to perform work on the unit.**

Failure to comply could result in death or serious injury.

Installation, maintenance, inspection, and servicing must be performed only by authorized personnel familiar with installation, adjustment, and maintenance of this equipment.

**Do not perform work on the unit while wearing loose clothing, jewelry or without eye protection.**

Failure to comply could result in death or serious injury.

Remove all metal objects such as watches and rings, secure loose clothing, and wear eye protection before beginning work on the unit.

**Do not use damaged wires, place excessive stress on wiring, or damage the wire insulation.**

Failure to comply could result in death or serious injury.

#### Fire Hazard

**Tighten all terminal screws to the specified tightening torque.**

Loose electrical connections could result in death or serious injury by fire due to overheating of electrical connections.

### CAUTION

**Carry all standard configuration and peripheral devices in a method suitable for the weight of the device.**

Incorrectly handling devices could cause them to fall and result in injury or damage to the device.

**NOTICE****Observe proper electrostatic discharge procedures (ESD) when handling the unit and circuit boards.**

Failure to comply may result in ESD damage to the unit circuitry.

**Do not use unshielded cable for control wiring.**

Failure to comply may cause electrical interference resulting in poor system performance. Use shielded, twisted-pair wires and ground the shield to the shield ground terminal E (G) of the unit.

**Check all the wiring to ensure that all connections are correct after installing the unit and connecting any other devices.**

Failure to comply could result in damage to the unit.

**Do not operate damaged equipment.**

Failure to comply could result in further damage to the equipment.

Do not connect or operate any equipment with visible damage or missing parts.

## 7.2 Regenerative Unit Options and Peripheral Devices

**Table 7.1** lists the names of the various peripheral devices, accessories, and options available for Yaskawa regenerative units. Contact Yaskawa or your Yaskawa agent to order these peripheral devices.

- Peripheral Device Selection: Refer to the Yaskawa catalog for selection and part numbers.
- Peripheral Device Installation: Refer to the corresponding option manual for installation instructions.

**Table 7.1 Available Peripheral Devices**

Option	Model Number	Description
<b>Power Options</b>		
24 V Power Supply	PS-A10LB (200 V class) PS-A10HB (400 V class)	Provides power supply for the control circuit and option boards. <b>Note:</b> Parameter settings cannot be changed when the drive is operating solely from this power supply.
<b>Interface Options</b>		
USB Copy Unit (RJ-45/ USB compatible plug)	JVOP-181	<ul style="list-style-type: none"> <li>• Can copy parameter settings easily and quickly to be later transferred to another regenerative unit.</li> <li>• Adapter for connecting regenerative unit to the USB port of a PC.</li> </ul>
PC Cable	Commercially available USB2.0 A/B cable.	Connect regenerative unit and PC when using DriveWizard Plus. The cable length must be 3 m or less.
LED Operator	JVOP-182	5-digit LED operator; maximum cable length for remote usage: 3 m
LCD Operator Extension Cable	WV001: 1 m WV003: 3 m	Cable for connecting the LCD operator.
<b>Mechanical Options</b>		
Attachment for External Heatsink	–	Attachment for External Heatsink
<b>Communications Option Cards</b>		
MECHATROLINK-II Interface	SI-T3	Used for running or stopping the regenerative unit, setting or referencing parameters, and monitoring input current, output voltage, or similar items through MECHATROLINK-II communication with the host controller.
CC-Link Interface	SI-C3 Available soon.	Used for running or stopping the regenerative unit, setting or referencing parameters, and monitoring input current, output voltage, or similar items through CC-Link communication with the host controller.
DeviceNet Interface	SI-N3 Available soon.	Used for running or stopping the regenerative unit, setting or referencing parameters, and monitoring input current, output voltage, or similar items through DeviceNet communication with the host controller.
PROFIBUS-DP Interface	SI-P3 Available soon.	Used for running or stopping the regenerative unit, setting or referencing parameters, and monitoring input current, output voltage, or similar items through PROFIBUS-DP communication with the host controller.
CANopen Interface	SI-S3 Available soon.	Used for running or stopping the regenerative unit, setting or referencing parameters, and monitoring input current, output voltage, or similar items through CANopen communication with the host controller.
<b>Monitor Option Cards</b>		
Analog Monitor	AO-A3	Outputs analog signal for monitoring the output state (input frequency, output voltage etc.) of the regenerative unit. Output resolution: 11 bit signed (1/2048) Output voltage: 0 to 10 Vdc (non-isolated) Terminals: 2 analog outputs
Digital Output	DO-A3	Outputs isolated type digital signal for monitoring the run state of the regenerative unit (alarm signal, during run, etc.) Terminals: 6 photocoupler outputs (48 V, 50 mA or less) 2 relay contact outputs (250 Vac, 1 A or less 30 Vdc, 1 A or less)



## 7.3 Connecting Standard Configuration Devices and Peripheral Devices

**Figure 7.1** illustrates how to configure the regenerative unit with standard configuration devices, peripheral devices, and options.

**Note:** Refer to *Standard Connection Diagram on page 32* for details on connecting standard configuration devices.

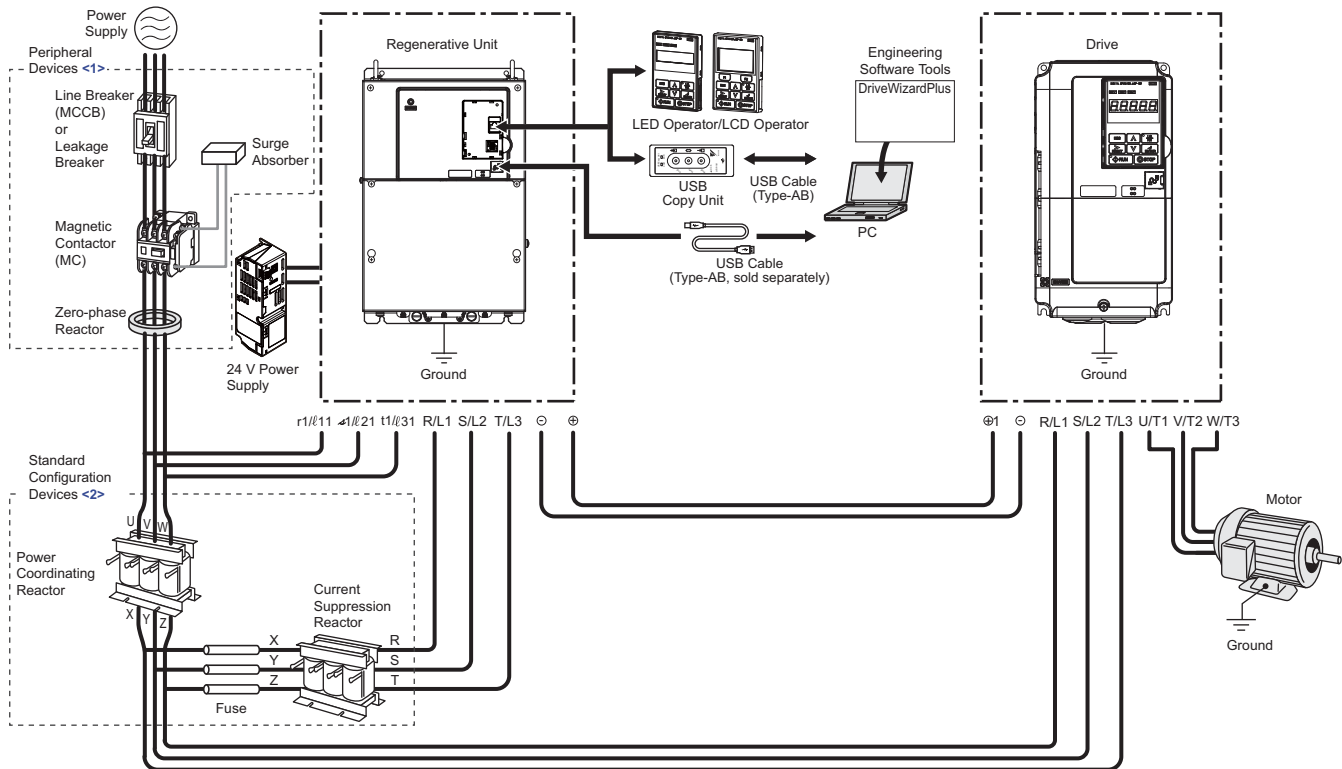

<1> Select these peripheral devices for the drive. Refer to the drive manual for more detailed instructions regarding these devices.

<2> A corresponding power coordinating reactor and current suppression reactor that consider the saturation current and thermal factors are required for each model of regenerative unit. Always install the specified devices.

**Figure 7.1** Connecting Standard Configuration Devices and Peripheral Devices

**Note:** If the regenerative unit is set to trigger a fault output when the fault restart function is activated ( $L5-02 = 1$ ), then a sequence to interrupt power when a fault occurs will turn off the power to the regenerative unit while the regenerative unit attempts to restart. The default setting for L5-02 is 0 (fault output active during restart).

## 7.4 Standard Configuration Devices Wiring

Install the standard configuration devices listed below when installing the regenerative unit. Refer to the product catalog for selection of standard configuration devices.

- Power Coordinating Reactor
- Current Suppression Reactor
- Fuse
- Fuse Holder

### ◆ Wire Gauges and Tightening Torque

Use the [Table 7.2](#) to select the appropriate wires and crimp terminals for power coordinating reactor, current suppression reactor, and fuse holder.

**Note:** Wire gauge recommendations based on continuous current ratings using 75°C 600 Vac vinyl-sheathed wire assuming ambient temperature within 40°C.

Consider the amount of voltage drop when selecting wire gauges. Increase the wire gauge when the voltage drop is greater than 2% of motor rated voltage. Ensure the wire gauge is suitable for the terminal block. Use the following formula to calculate the amount of voltage drop:

$$\text{Line drop voltage (V)} = \sqrt{3} \times \text{wire resistance } (\Omega/\text{km}) \times \text{wire length (m)} \times \text{current (A)} \times 10^{-3}$$

**Table 7.2 Wire Gauge and Torque Specifications**

Model	Terminals	For Asia <1>		For U.S.A. <2>		For Europe and China <3>		Screw Size	Tightening Torque N·m
		Recomm. Gauge mm <sup>2</sup>	Applicable Gauge mm <sup>2</sup>	Recomm. Gauge AWG, kcmil	Applicable Gauge AWG, kcmil	Recomm. Gauge mm <sup>2</sup>	Applicable Gauge mm <sup>2</sup>		
<b>200 V Class</b>									
2A03P5	U, V, W	3.5	3.5 to 14	12	12 to 6	4	4 to 16	M4	2.1 to 2.3
	X, Y, Z								
	R, S, T								
2A0005	U, V, W	3.5	3.5 to 14	12	12 to 6	4	4 to 16	M4	2.1 to 2.3
	X, Y, Z								
	R, S, T								
2A0007	U, V, W	3.5	3.5 to 14	12	12 to 6	4	4 to 16	M4	2.1 to 2.3
	X, Y, Z								
	R, S, T								
2A0010	U, V, W	5.5	5 to 14	10	10 to 6	4	4 to 16	M4	2.1 to 2.3
	X, Y, Z								
	R, S, T								
2A0014	U, V, W	8	8 to 14	8	8 to 6	6	6 to 16	M4	2.1 to 2.3
	X, Y, Z								
	R, S, T								
2A0017	U, V, W	14	14 to 38	8	8 to 1	10	10 to 25	M6	3.6 to 4.0
	X, Y, Z								
	R, S, T								
2A0020	U, V, W	14	14 to 38	6	6 to 1	10	10 to 25	M6	3.6 to 4.0
	X, Y, Z								
	R, S, T								
2A0028	U, V, W	22	22 to 38	4	4 to 1	16	16 to 35	M6	3.6 to 4.0
	X, Y, Z								
	R, S, T								
2A0035	U, V, W	38	38 to 70	2	2 to 2/0	25	25 to 70	M8	5.4 to 6.0
	X, Y, Z								
	R, S, T								

## 7.4 Standard Configuration Devices Wiring

Model	Terminals	For Asia <1>		For U.S.A. <2>		For Europe and China <3>		Screw Size	Tightening Torque N·m
		Recomm. Gauge mm <sup>2</sup>	Applicable Gauge mm <sup>2</sup>	Recomm. Gauge AWG, kcmil	Applicable Gauge AWG, kcmil	Recomm. Gauge mm <sup>2</sup>	Applicable Gauge mm <sup>2</sup>		
2A0053	U, V, W	50	50 to 150	2/0	2/0 to 250	50	50 to 95	M8	13.5 to 15.0
	X, Y, Z								
	R, S, T								
2A0073	U, V, W	80	80 to 150	1/0 × 2P	1/0 to 300	70	70 to 150	M12	32.0 to 40.0
	X, Y, Z								
	R, S, T								
2A0105	U, V, W	80 × 2P	80 to 325	3/0 × 2P	3/0 to 600	95 × 2P	95 to 240	M12	32.0 to 40.0
	X, Y, Z								
	R, S, T								
<b>400 V Class</b>									
4A03P5	U, V, W	3.5	3.5 to 14	10	10 to 6	4	4 to 16	M4	2.1 to 2.3
	X, Y, Z								
	R, S, T								
4A0005	U, V, W	3.5	3.5 to 14	10	10 to 6	4	4 to 16	M4	2.1 to 2.3
	X, Y, Z								
	R, S, T								
4A0007	U, V, W	3.5	3.5 to 14	12	12 to 6	4	4 to 16	M4	2.1 to 2.3
	X, Y, Z								
	R, S, T								
4A0010	U, V, W	3.5	3.5 to 14	12	12 to 6	4	4 to 16	M4	2.1 to 2.3
	X, Y, Z								
	R, S, T								
4A0014	U, V, W	3.5	3.5 to 14	10	10 to 6	4	4 to 16	M4	2.1 to 2.3
	X, Y, Z								
	R, S, T								
4A0017	U, V, W	8	8 to 38	10	10 to 1	10	10 to 25	M6	3.6 to 4.0
	X, Y, Z								
	R, S, T								
4A0020	U, V, W	8	8 to 38	8	8 to 1	10	10 to 25	M6	3.6 to 4.0
	X, Y, Z								
	R, S, T								
4A0028	U, V, W	8	8 to 38	8	8 to 1	10	10 to 25	M6	3.6 to 4.0
	X, Y, Z								
	R, S, T								
4A0035	U, V, W	14	14 to 70	6	6 to 2/0	10	10 to 70	M8	5.4 to 6.0
	X, Y, Z								
	R, S, T								
4A0043	U, V, W	14	14 to 70	4	4 to 2/0	10	10 to 70	M8	5.4 to 6.0
	X, Y, Z								
	R, S, T								
4A0053	U, V, W	22	22 to 70	4	4 to 2/0	16	16 to 70	M8	5.4 to 6.0
	X, Y, Z								
	R, S, T								
4A0073	U, V, W	30	30 to 70	2	2 to 2/0	25	25 to 70	M8	5.4 to 6.0
	X, Y, Z								
	R, S, T								
4A0105	U, V, W	50	50 to 150	2/0	2/0 to 300	50	50 to 150	M10	18.0 to 23.0
	X, Y, Z								
	R, S, T								
4A0150	U, V, W	100	100 to 150	250	250 to 300	95	95 to 240	M12	32.0 to 40.0
	X, Y, Z								
	R, S, T								

## 7.4 Standard Configuration Devices Wiring

Model	Terminals	For Asia <1>		For U.S.A. <2>		For Europe and China <3>		Screw Size	Tightening Torque N·m
		Recomm. Gauge mm <sup>2</sup>	Applicable Gauge mm <sup>2</sup>	Recomm. Gauge AWG, kcmil	Applicable Gauge AWG, kcmil	Recomm. Gauge mm <sup>2</sup>	Applicable Gauge mm <sup>2</sup>		
4A0210	U, V, W	80 × 2P	80 to 325	3/0 × 2P	3/0 to 600	95 × 2P	95 to 240	M12	32.0 to 40.0
	X, Y, Z								
	R, S, T								
4A0300	U, V, W	100 × 2P	100 to 325	250 × 2P	250 to 600	95 × 2P	95 to 240	M12	32.0 to 40.0
	X, Y, Z								
	R, S, T								

<1> Gauges listed here are for use in Japan.

<2> Gauges listed here are for use in the United States.

<3> Gauges listed here are for use in Europe and China.

### ◆ Terminal Functions

#### ■ Power Coordinating Reactor

Table 7.3 Terminal Function (Power Coordinating Reactor)

Terminal	Function
U	Power Coordinating Reactor Inputs
V	
W	
X	Power Coordinating Reactor Outputs
Y	
Z	

These terminals are connected to the power supply.

These terminals are connected to the connected drive device input terminals and input fuses.

#### ■ Current Suppression Reactor

Table 7.4 Terminal Function (Current Suppression Reactor)

Terminal	Function
X	Current Suppression Reactor Inputs
Y	
Z	
R	Current Suppression Reactor Outputs
S	
T	

These terminals are connected to the input fuses.

These terminals are connected to the regenerative unit.

### ◆ Specification

Table 7.5 Rating (200 V Class)

Voltage Class		200 V Class											
Model		2A03P5	2A0005	2A0007	2A0010	2A0014	2A0017	2A0020	2A0028	2A0035	2A0053	2A0073	2A0105
Power Coordinating Reactor	Rated Current [A]	20	30	40	60	80	90	120	160	200	280	360	500
	Inductance [mH]	0.53	0.35	0.265	0.18	0.13	0.12	0.09	0.07	0.05	0.038	0.026	0.02
	Heat Loss (W)	30	45	40	65	75	90	90	100	100	94	120	170
Current Suppression Reactor	Rated Current [A]	15	15	20	40	40	50	60	80	100	153	209	306
	Inductance [mH]	0.31	0.31	0.15	0.1	0.1	0.06	0.05	0.04	0.03	0.02	0.015	0.01
	Heat Loss (W)	22	22	21	32	32	31	35	48	46	50	65	85
Fuse	Rated Current [A]	20	25	32	50	63	80	100	125	160	200	350	500
	Heat Loss (W)	1.0	1.5	2.3	3.5	5.7	6.4	5.8	8.9	11.2	14.4	35.9	44.3

Table 7.6 Rating (400 V Class)

Voltage Class		400 V Class							
Model		4A03P5	4A0005	4A0007	4A0010	4A0014	4A0017	4A0020	4A0028
Power Coordinating Reactor	Rated Current [A]	10	15	20	30	40	50	60	80
	Inductance [mH]	2.2	1.42	1.06	0.7	0.53	0.42	0.36	0.26
	Heat Loss (W)	40	50	40	65	60	90	90	95
Current Suppression Reactor	Rated Current [A]	7.5	7.5	10	15	25	25	30	40
	Inductance [mH]	1.2	1.2	0.6	0.4	0.3	0.3	0.2	0.15
	Heat Loss (W)	21	21	19	23	36	36	33	40
Fuse	Rated Current [A]	16	16	16	25	40	40	50	63
	Heat Loss (W)	0.8	1.2	1.7	3.1	4.5	5.9	7.0	10.3

Voltage Class		400 V Class							
Model		4A0035	4A0043	4A0053	4A0073	4A0105	4A0150	4A0210	4A0300
Power Coordinating Reactor	Rated Current [A]	90	120	150	200	250	330	490	660
	Inductance [mH]	0.24	0.18	0.15	0.11	0.09	0.06	0.04	0.03
	Heat Loss (W)	100	130	112	138	154	169	210	300
Current Suppression Reactor	Rated Current [A]	50	60	75	100	161	237	326	466
	Inductance [mH]	0.12	0.1	0.08	0.06	0.04	0.03	0.02	0.013
	Heat Loss (W)	46	56	81	72	95	105	120	160
Fuse	Rated Current [A]	80	100	125	160	250	350	500	630
	Heat Loss (W)	14.3	18.0	19.9	30.3	29.8	47.8	51.1	77.9

## 7.5 Installing Peripheral Devices

This section describes the proper steps and precautions to take when installing or connecting various peripheral devices to the regenerative unit.

**NOTICE:** Use a class 2 power supply when connecting to the control terminals. Improper application of peripheral devices could result in regenerative unit performance degradation due to improper power supply. Refer to NEC Article 725 Class 1, Class 2, and Class 3 Remote-Control, Signaling, and Power Limited Circuits for requirements concerning class 2 power supplies.

### ◆ Installing a Molded Case Circuit Breaker (MCCB) or Residual Current Device (RCD)

Install an MCCB or RCD for line protection between the drive power supply and the main circuit power supply input terminals R/L1, S/L2, and T/L3. This protects the main circuit and devices wired to the main circuit while also providing overload protection.

Consider the following when selecting and installing an MCCB or an RCD:

- The capacity of the MCCB or RCD should be 1.5 to 2 times the rated output current of the drive. Use an MCCB or RCD to keep the drive from faulting out instead of using overheat protection (150% for one minute at the rated output current).
- If several drives are connected to one MCCB or RCD that is shared with other equipment, use a sequence that shuts the power OFF when errors are output by using magnetic contactor (MC) as shown in [Figure 7.2](#).

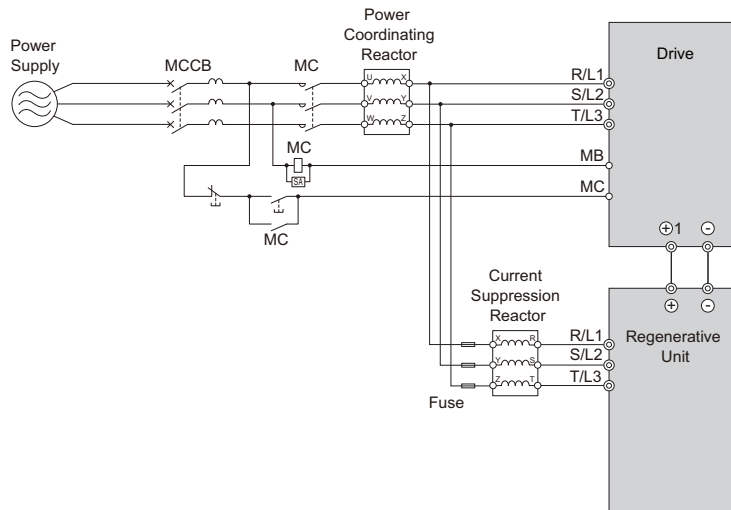

Figure 7.2 Power Supply Interrupt Wiring (Example)

**WARNING!** Electrical Shock Hazard. Disconnect the MCCB (or RCD) and MC before wiring terminals. Failure to comply may result in serious injury or death.

### ■ Application Precautions when Installing an RCD

Drive outputs generate high-frequency leakage current as a result of high-speed switching. Install an RCD on the input side of the drive to switch off potentially harmful leakage current.

Use an RCD with harmonic countermeasures and with a rated operating current of 30 mA minimum for each connected drive at the power supply side to eliminate harmonic leakage current and suppress any potentially harmful frequencies.

Leakage current can cause unprotected components to operate incorrectly. If this is a problem, lower the carrier frequency, replace the components in question with parts protected against harmonic current, or increase the sensitivity amperage of the circuit interrupter to at least 200 mA per drive.

Factors in determining leakage current:

- Size of the drive
- EMI/RFI filter
- Carrier frequency
- Motor cable type and length

Select an interrupter that senses all types of current (AC and DC) and high frequency currents to safely protect the system.

---

## ◆ Installing a Magnetic Contactor at the Power Supply Side

### ■ Disconnecting the Power Supply

Instead of an MCCB, you can also use an MC in the sequence to turn off the power supply for the main circuits when protection functions in the drive are activated or for emergency stop operations. However, if an MC at the input (primary side) to the drive is used to force the drive to stop, it will stop without performing regenerative operation. Create the sequence carefully.

**NOTICE:** Do not connect electromagnetic switches or MCs to the output motor circuits without proper sequencing. Improper sequencing of output motor circuits could result in damage to the drive.

**NOTICE:** Install an MC on the input side of the drive when the drive should not automatically restart after power loss. To get the full performance life out of the electrolytic capacitors and circuit relays, refrain from switching the drive power supply off and on more than once every 30 minutes. Frequent use can damage the drive. Use the drive to stop and start the motor.

**NOTICE:** Use a magnetic contactor (MC) to ensure that power to the drive can be completely shut off when necessary. The MC should be wired so that it opens when a fault output terminal is triggered.

**Note:** Set up a delay that prevents the MC from opening prematurely to continue operating the drive through a momentary power loss.

---

## ◆ Connecting a Surge Absorber

A surge absorber suppresses surge voltage generated from switching an inductive load near the drive. Inductive loads include magnetic contactors, relays, valves, solenoids, and brakes. Always use a surge absorber or diode when operating with an inductive load.

**WARNING! Fire Hazard.** Do not connect surge absorbers to the drive output power terminals. Failure to comply may result in serious injury or death by fire or flying debris.

---

## ◆ Attachment for External Heatsink Mounting

An external attachment can be used to project the heatsink outside of an enclosure to ensure that there is sufficient air circulation around the heatsink.

Contact a Yaskawa sales representative or Yaskawa directly for more information on this attachment.





# Appendix: A

## Specifications

---

This chapter provides the specifications of the regenerative unit and describes the derating methods.

<b>A.1</b>	<b>POWER RATINGS</b> .....	<b>134</b>
<b>A.2</b>	<b>REGENERATIVE UNIT SPECIFICATIONS</b> .....	<b>135</b>
<b>A.3</b>	<b>HEAT LOSS DATA</b> .....	<b>136</b>
<b>A.4</b>	<b>DERATING DATA</b> .....	<b>137</b>

## A.1 Power Ratings

**Table A.1 Power Ratings (Three-Phase 200 V Class)**

Item		Specification											
Model		2A03P5	2A0005	2A0007	2A0010	2A0014	2A0017	2A0020	2A0028	2A0035	2A0053	2A0073	2A0105
Maximum Applicable Motor Capacity [kW]		3.7	5.5	7.5	11	15	18.5	22	30	37	55	75	110
Rating	Rated Output Capacity [kW] <1>	3.5	5	7	10	14	17	20	28	35	53	73	105
Rating	Rated Output Current (DC) [A]	14	20	27	41	55	68	81	112	138	207	282	413
	Rated Input Current (AC) [A]	10	15	20	30	41	50	60	83	102	153	209	306

<1> Rated output capacity is calculated with a rated input voltage of 200 V.

**Table A.2 Power Ratings (Three-Phase 400 V Class)**

Item		Specification							
Model		4A03P5	4A0005	4A0007	4A0010	4A0014	4A0017	4A0020	4A0028
Maximum Applicable Motor Capacity [kW]		3.7	5.5	7.5	11	15	18.5	22	30
Rating	Rated Output Capacity [kW] <1>	3.5	5	7	10	14	17	20	28
Rating	Rated Output Current (DC) [A]	7	11	15	22	30	36	43	58
	Rated Input Current (AC) [A]	5	8	11	16	22	27	32	43

<1> Rated output capacity is calculated with a rated input voltage of 400 V.

Item		Specification							
Model		4A0035	4A0043	4A0053	4A0073	4A0105	4A0150	4A0210	4A0300
Maximum Applicable Motor Capacity [kW]		37	45	55	75	110	160	220	315
Rating	Rated Output Capacity [kW] <1>	35	43	53	73	105	150	210	300
Rating	Rated Output Current (DC) [A]	73	89	109	149	217	320	440	629
	Rated Input Current (AC) [A]	54	66	81	110	161	237	326	466

<1> Rated output capacity is calculated with a rated input voltage of 400 V.

## A.2 Regenerative Unit Specifications

Item		Specification
Input	Rated Voltage Rated Frequency	200 V Class: 200 to 240 Vac 50/60 Hz 400 V Class: 380 to 480 Vac 50/60 Hz
	Allowable Voltage Fluctuation	-15 to +10%
	Allowable Frequency Fluctuation	±2%
Control Characteristics	Control Method	120° excitation method
	Input Power Factor	0.9 minimum (for rated load)
	Regenerative Torque	150% 30 s, 100% 25% ED 60 s, 80% continuous
	Voltage Reference Range	200 V Class: 300 to 360 Vdc 400 V Class: 600 to 730 Vdc
	Main Control Functions	Cooling fan on/off switch, MEMOBUS/Modbus Communication (RS-422/RS-485 maximum, 115.2 kbps)
Protection Functions	Momentary Overcurrent Protection	Operation stops when unit current is approximately 250% of the rated power supply current.
	Open Fuse	Operation stops if the fuse opens.
	Overload	Operation stops when unit current is 150% of the rated power supply current for 30 s.
	Overvoltage Protection (Output)	200 V class: Stops when DC bus voltage exceeds approximately 410 Vdc 400 V class: Stops when DC bus voltage exceeds approximately 820 Vdc
	Overvoltage Protection (Input)	200 V class: Stops when input voltage exceeds approximately 227 Vac 400 V class: Stops when input voltage exceeds approximately 554 Vac
	Undervoltage Protection (Output)	200 V class: Stops when DC bus voltage is below approximately 190 Vdc 400 V class: Stops when DC bus voltage is below approximately 380 Vdc
	Undervoltage Protection (Input)	200 V class: Stops when input voltage is below approximately 150 Vac 400 V class: Stops when input voltage is below approximately 300 Vac
	Momentary Power Loss Ride-Thru	Immediate stop after Momentary Power Loss is detected.
	Power Supply Frequency Fault	Operation stops if the input frequency deviates by ±6 Hz of rated frequency.
	Heatsink Overheat Protection	Thermistor protection
	DC Bus Charge LED	Remains lit until DC bus voltage is below 50 V
Environment	Area of Use	Indoors
	Ambient Temperature	IP00/Open Type enclosure: -10°C to +50°C IP20/NEMA Type 1 enclosure: -10°C to +40°C
	Humidity	95 RH% or less (no condensation)
	Vibration/Shock	2A03P5 to 2A0053, 4A03P5 to 4A0073 10 to 20 Hz at 9.8 m/s <sup>2</sup> 20 to 55 Hz at 5.9 m/s <sup>2</sup> 2A0073 to 2A0105, 4A0105 to 4A0300 10 to 20 Hz at 9.8 m/s <sup>2</sup> 20 to 55 Hz at 2.0 m/s <sup>2</sup>
	Storage Temperature	-20°C to +60°C
	Altitude	1000 m or lower, up to 3000 m with derating.
Protection Design		IP00/Open Type enclosure, IP20/NEMA Type 1 enclosure
Standard		<ul style="list-style-type: none"> <li>• UL508C</li> <li>• IEC/EN 61800-5-1</li> <li>• IEC/EN 61800-3</li> </ul>

## A.3 Heat Loss Data

Table A.3 Heat Loss

Model	Heatsink Loss (W) <1>	Interior Unit Loss (W) <1>	Total Loss (W) <1>
<b>200 V Class</b>			
2A03P5	31	22	53
2A0005	51	27	78
2A0007	76	33	109
2A0010	99	39	138
2A0014	149	49	198
2A0017	155	53	208
2A0020	201	67	268
2A0028	270	98	368
2A0035	295	127	422
2A0053	494	164	658
2A0073	609	236	845
2A0105	910	365	1275
<b>400 V Class</b>			
4A03P5	16	21	37
4A0005	27	24	51
4A0007	41	28	69
4A0010	53	31	84
4A0014	80	38	118
4A0017	91	44	135
4A0020	114	50	164
4A0028	174	66	240
4A0035	169	74	243
4A0043	221	91	312
4A0053	266	109	375
4A0073	397	164	561
4A0105	572	255	827
4A0150	869	336	1205
4A0210	1193	532	1725
4A0300	1534	630	2164

<1> Values are the regenerative torque at 80% continuous rating.

## A.4 Derating Data

The regenerative unit can be operated above the rated temperature, altitude, and default carrier frequency by derating the unit capacity.

### ◆ Temperature Derating

To ensure the maximum performance life, the regenerative unit output current must be derated as shown in *Figure A.1* when the regenerative unit is installed in areas with high ambient temperature or if regenerative units are mounted side-by-side in a cabinet. In order to ensure reliable overload protection, set parameters L8-35 according to the installation conditions.

### ■ Parameter Settings

If the ambient temperature is higher than the rating or if regenerative units are installed side by side in the control panel, you must set the L8-12 and L8-35 parameters according to the installation conditions. Derate the output current according to *Figure A.1*

No.	Name	Description	Setting Value	Default Setting
L8-12	Ambient Temperature Setting	Adjust the Overload (oL2) protection level when the regenerative unit is installed in an environment that exceeds its ambient temperature rating.	-10 to +50	+40°C
L8-35	Installation Method Selection	0: IP00 Open Type Enclosure 1: Side-by-Side Mounting 2: IP20/NEMA Type 1 Enclosure 3: External Heatsink Installation	0 to 3	Default setting is determined by o2-04 (Unit Model Selection).

#### Setting 0: IP00 Open Type Enclosure

Regenerative unit operation between -10°C and +50°C allows 100% continuous current without derating.

#### Setting 1: Side-by-Side Mounting

Regenerative unit operation between -10°C and +30°C allows 100% continuous current without derating. Operation between +30°C and +50°C requires output current derating.

#### Setting 2: IP20/NEMA Type 1 Enclosure

Regenerative unit operation between -10°C and +40°C allows 100% continuous current without derating. Operation between +40°C and +50°C requires output current derating.

#### Setting 3: External Heatsink Installation

Regenerative unit operation between -10°C and +40°C allows 100% continuous current without derating. Operation between +40°C and +50°C requires output current derating.

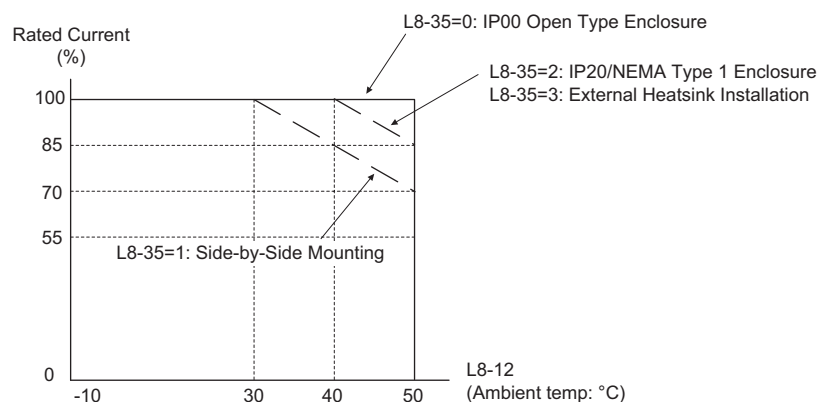

Figure A.1 Ambient Temperature and Installation Method Derating

### ◆ Altitude Derating

Standard ratings are valid for installation altitudes up to 1000 m. For installations from 1000 m to 3000 m, the regenerative unit rated voltage and the rated output current must be derated by 1% per 100 m.



# Appendix: B

## Parameter List

---

This appendix contains a full listing of all parameters and settings available in the regenerative unit.

<b>B.1</b>	<b>PARAMETER GROUPS</b> .....	<b>140</b>
<b>B.2</b>	<b>PARAMETER TABLES</b> .....	<b>141</b>
<b>B.3</b>	<b>DEFAULTS BY UNIT MODEL</b> .....	<b>158</b>

## B.1 Parameter Groups

Parameter Group	Name	Page	Parameter Group	Name	Page
<b>A1</b>	Initialization Parameters	<a href="#">141</a>	<b>L5</b>	Fault Restart	<a href="#">150</a>
<b>A2</b>	User Parameters	<a href="#">141</a>	<b>L8</b>	Drive Protection	<a href="#">150</a>
<b>b1</b>	Operation Mode Selection	<a href="#">142</a>	<b>o1</b>	Digital Operator Display Selection	<a href="#">151</a>
<b>b4</b>	Timer Function	<a href="#">142</a>	<b>o2</b>	Digital Operator Keypad Functions	<a href="#">152</a>
<b>C7</b>	DC Bus Voltage Control	<a href="#">142</a>	<b>o3</b>	Copy Function	<a href="#">152</a>
<b>F4</b>	Analog Monitor Card (AO-A3)	<a href="#">143</a>	<b>o4</b>	Maintenance Monitor Settings	<a href="#">152</a>
<b>F5</b>	Digital Monitor Card (DO-A3)	<a href="#">144</a>	<b>U1</b>	Operation Status Monitors	<a href="#">153</a>
<b>F6</b>	Communication Option Card	<a href="#">144</a>	<b>U2</b>	Fault Trace	<a href="#">155</a>
<b>H1</b>	Multi-Function Digital Inputs	<a href="#">145</a>	<b>U3</b>	Fault History	<a href="#">156</a>
<b>H2</b>	Multi-Function Relay Outputs	<a href="#">146</a>	<b>U4</b>	Maintenance Monitors	<a href="#">156</a>
<b>H3</b>	Multi-Function Analog Inputs	<a href="#">147</a>	<b>U6</b>	Operation Status Monitors	<a href="#">157</a>
<b>H4</b>	Multi-Function Analog Outputs	<a href="#">148</a>	<b>U9</b>	Operation Status Monitors	<a href="#">157</a>
<b>L2</b>	Momentary Power Loss Ride-Thru	<a href="#">150</a>			





## B.2 Parameter Tables

### ◆ A: Initialization Parameters

The A parameter group creates the operating environment for the regenerative unit. This includes the parameter Access Level, Control Method, Password, User Parameters and more.

 : Indicates that the parameter setting can be changed while the regenerative unit is operating.

No. (Address Hex)	Name	LCD Display	Description	Values
<b>A1: Initialization</b>				
A1-00 (100H)  </>	Language Selection	Select Language 0: English 1: ニホンゴ (Japanese) 7: Chinese	0: English 1: Japanese 7: Chinese	Default: 0 Min.: 0 Max.: 7
A1-01 (101H) 	Access Level Selection	Access Level 0: Operation Only 1: User Parameters 2: Advanced Level	0: View and set A1-01 and A1-04. U□-□□ parameters can also be viewed. 1: User Parameters (access to a set of parameters selected by the user, A2-01 to A2-32) 2: Advanced Access (access to view and set all parameters)	Default: 2 Min.: 0 Max.: 9999
A1-03 (103H)	Initialize Parameters	Init Parameters 0: No Initialize 1110: User Initialize 2220: 2-Wire Initial 3330: 3-Wire Initial 5550: oPE04 error reset	0: No initialization 1110: User Initialize (parameter values must be stored using parameter o2-03) 2220: 2-Wire initialization 3330: 3-Wire initialization 5550: oPE04 error reset	Default: 0 Min.: 0 Max.: 5550
A1-04 (104H)	Password	Enter Password	When the value set into A1-04 does not match the value set into A1-05, parameters A1-01 through A1-03, A1-06, and A2-01 through A2-33 cannot be changed.	Default: 0000 Min.: 0000 Max.: 9999
A1-05 (105H)	Password Setting	Select Password		
<b>A2: User Parameters</b>				
A2-01 (106H)	User Parameters 1	User Param 1	Recently edited parameters are listed here. The user can also select parameters to appear here for quicker access.	Default: b1-02 Range: A1-00 to o4-19
A2-02 (107H)	User Parameters 2	User Param 2		Default: b1-21 Range: A1-00 to o4-19
A2-03 (108H)	User Parameters 3	User Param 3		Default: – Range: A1-00 to o4-19
A2-04 to A2-32 (109H to 125H)	User Parameters 4 to 32	User Param 4 - 32		Default: – Range: A1-00 to o4-19
A2-33 (126H)	User Parameter Automatic Selection	User Parms Sel 0: Disabled 1: Enabled	Determines whether recently edited parameters are saved to the second half of the User Parameters (A2-17 to A2-32) for quicker access. 0: Parameters A2-01 to A2-32 are reserved for the user to create a list of User Parameters. 1: Save history of recently viewed parameters. Recently edited parameters will be saved to A2-17 through A2-32 for quicker access.	Default: 0 Range: 0 to 1

<1> Parameter setting value is not reset to the default value when the regenerative unit is initialized.

## B.2 Parameter Tables

### ◆ b: Application

Application parameters configure the source of the operation mode selection.

No. (Address Hex)	Name	LCD Display	Description	Values
<b>b1: Operation Mode Selection</b>				
b1-02 (181H)	Run Command Selection 1	Run Source 1 0: Digital operator 1: Digital Inputs 2: Communication 3: Option PCB	0: Digital operator 1: Digital input terminals 2: MEMOBUS/Modbus communications 3: Option PCB	Default: 1 Range: 0 to 3
b1-06 (185H)	Digital Input Reading	Cntl Input Scans 1: Scan 2: Scans	Defines how the digital inputs are read. The inputs are acted upon every 1 ms or 2 ms depending upon the setting. 0: Input status is read once and processed immediately (for quicker response) 1: Input is read twice and processed only if the status is the same in both readings (robust against noisy signals)	Default: 1 Range: 0, 1
b1-08 (187H)	Run Command Selection in Programming Mode	RUN dur PRG Mode 0: Run Disabled@PRG 1: ModeRun Enabled@PRG 2: Prg only @ Stop	Allow the regenerative unit to run while in Programming Mode. 0: Run command is not accepted while in Programming Mode. 1: Run command is accepted while in Programming Mode. 2: Prohibit entering Programming Mode during run.	Default: 0 Range: 0 to 2
b1-17 (1C6H)	Run Command at Power Up	Run Cmd @ Pwr On 0: Cycle Ext Run 1: Accept Ext Run	Determines whether an external Run command that is active during power up will start the regenerative unit. 0: Disregarded. A new Run Command must be issued. 1: Allowed. Regenerative unit will start immediately if Run Command is present at power up.	Default: 0 Range: 0, 1
b1-21 (766H)	Operator Operation Mode	Run Mode Sel 0: Manual Run 1: Auto run	Sets the operation mode when b1-02 (Run Command Selection) is set to 0 (LED operator or LCD operator). 0: Forced operation 1: Automatic operation	Default: 1 Range: 0, 1
<b>b4: Timer Function</b>				
b4-01 (1A3H)	Timer Function On-Delay Time	Delay-ON Timer	Sets the on-delay times for a digital timer output (H2-□□=12). The output is triggered by a digital input programmed to H1-□□=18.	Default: 0.0 s Min.: 0.0 Max.: 3000.0
b4-02 (1A4H)	Timer Function Off-Delay Time	Delay-OFF Timer	Sets the off-delay times for a digital timer output (H2-□□=12). The output is triggered by a digital input programmed to H1-□□=18.	Default: 0.0 s Min.: 0.0 Max.: 3000.0

### ◆ C: Tuning





Tuning parameters set the voltage increase time, voltage decrease time, carrier frequency, and DC bus voltage control.

No. (Address Hex)	Name	LCD Display	Description	Values
<b>C7: DC Bus Voltage Control</b>				
C7-14 (759H)	Bias Voltage at Operation Start	Vd Bias@Start	Normally, it is not necessary to change the setting of this parameter. Adjusts the level to start regenerative operation for automatic operation. Operation starts when the Voltage Deviation (U1-73) exceeds the sum of C7-14 and C7-15. Operation stops when Voltage Deviation goes below the set value of C7-14.	200 V Class Default: 2.0 Min.: 00.0 Max.: 50.0 400 V Class Default: 4.0 Min.: 0.0 Max.: 100.0

No. (Address Hex)	Name	LCD Display	Description	Values
C7-15 (75AH)	Voltage Hysteresis Width at Operation Start/Stop	Vd Hysteresis	Normally, it is not necessary to change the setting of this parameter. Adjusts the level to start regenerative operation for automatic operation. Operation starts when the Voltage Deviation (U1-73) exceeds the sum of C7-14 and C7-15. Operation stops when Voltage Deviation goes below the set value of C7-14.	200 V Class Default: 3.0 Min.: 00.0 Max.: 50.0 400 V Class Default: 6.0 Min.: 0.0 Max.: 100.0
C7-16 (75BH)	Minimum Operation Time	Minimum On Time	Sets the minimum operation time from the start of operation to when operation stops in automatic operation.	Default: 1.00 s Min.: 0.00 Max.: 600.00
C7-43 (112AH)	Input Voltage Offset Adjustment	Vac Bias Adj Sel	There is normally no need to change this parameter from the default value. This parameter is for factory setting. If the setting is not correct, the regenerative unit may be damaged. 0: Standard 1: Start offset adjustment. (The parameter returns to 0 after it is set.) 2: Offset adjustment not required. (The parameter returns to 0 after it is set.)	Default: 0 Range: 0 to 2
C7-50 (113BH)	Operation Ready ON Delay Time	Conv READY delay	Sets the delay time to turn on the Operation Ready signal (H2-□□=6).	Default: 0 ms Min.: 0 Max.: 500
C7-53 (111FH)	Automatic Operation Stop Power	Autorun Power	Sets the power to stop the automatic operation. When in automatic operation, Regenerative unit stops automatic operation when the power becomes lower than regenerative load.	Default: 50% Min.: 0% Max.: 100%

## ◆ F: Options

F parameters program the regenerative unit for communication options and to function with option cards.

No. (Address Hex)	Name	LCD Display	Description	Values
<b>F4: Analog Monitor Card (AO-A3)</b>				
F4-01 (391H)	Terminal V1 Monitor Selection	AO Ch1 Select	Sets the monitor signal for output from terminal V1. Set this parameter to the last three digits of the desired U□-□□□ monitor. Some U parameters are available only in certain control modes.	Default: 0 Min.: 000 Max.: 408
F4-02 (392H) 	Terminal V1 Monitor Gain	AO Ch1 Gain	Sets the gain for voltage output via terminal V1.	Default: 100.0% Min.: -999.9% Max.: 999.9%
F4-03 (393H)	Terminal V2 Monitor Selection	AO Ch2 Select	Sets the monitor signal for output from terminal V2. Set this parameter to the last three digits of the desired U□-□□□ monitor. Some U parameters are available only in certain control modes.	Default: 0 Min.: 000 Max.: 408
F4-04 (394H) 	Terminal V2 Monitor Gain	AO Ch2 Gain	Sets the gain for voltage output via terminal V2.	Default: 50.0% Min.: -999.9% Max.: 999.9%
F4-05 (395H) 	Terminal V1 Monitor Bias	AO Ch1 Bias	Sets the amount of bias added to the voltage output via terminal V1.	Default: 0.0% Min.: -999.9% Max.: 999.9%
F4-06 (396H) 	Terminal V2 Monitor Bias	AO Ch2 Bias	Sets the amount of bias added to the voltage output via terminal V2.	Default: 0.0% Min.: -999.9% Max.: 999.9%

## B.2 Parameter Tables

No. (Address Hex)	Name	LCD Display	Description	Values
F4-07 (397H)	Terminal V1 Signal Level	AO Opt Level Ch1 0: 0-10 VDC 1: -10 +10 VDC	0: 0 to 10 V 1: -10 to 10 V	Default: 0 Min.: 0 Max.: 1
F4-08 (398H)	Terminal V2 Signal Level	AO Opt Level Ch2 0: 0-10 VDC 1: -10 +10 VDC	0: 0 to 10 V 1: -10 to 10 V	Default: 0 Min.: 0 Max.: 1
<b>F5: Digital Output Card (DO-A3)</b>				
F5-01 (399H)	Terminal P1-PC Output Selection	DO Ch1 Select	Sets the function for contact output terminals M1-M2, M3-M4, and photocoupler output terminals P1 through P6.	Default: F Min.: 0 Max.: 160
F5-02 (39AH)	Terminal P2-PC Output Selection	DO Ch2 Select		Default: F Min.: 0 Max.: 160
F5-03 (39BH)	Terminal P3-PC Output Selection	DO Ch3 Select		Default: F Min.: 0 Max.: 160
F5-04 (39CH)	Terminal P4-PC Output Selection	DO Ch4 Select		Default: F Min.: 0 Max.: 160
F5-05 (39DH)	Terminal P5-PC Output Selection	DO Ch5 Select		Default: F Min.: 0 Max.: 160
F5-06 (39EH)	Terminal P6-PC Output Selection	DO Ch6 Select		Default: F Min.: 0 Max.: 160
F5-07 (39FH)	Terminal M1-M2 Output Selection	DO Ch7 Select		Default: F Min.: 0 Max.: 160
F5-08 (3A0H)	Terminal M3-M4 Output Selection	DO Ch8 Select		Default: F Min.: 0 Max.: 160
<b>F6: Communication Option Card</b>				
For details on a specific option card, refer to the instruction manual for the option card.				

## ◆ H: Multi-Function Terminals

H parameters assign functions to the multi-function input and output terminals.

No. (Address Hex)	Name	LCD Display	Description	Values
<b>H1: Multi-Function Digital Inputs</b>				
H1-01 (438H)	Multi-Function Digital Input Terminal S1 Function Selection	Term S1 Func Sel	Assigns a function to the multi-function digital inputs S1 to S8. <b>Note:</b> Set unused terminals to F.	Default: 3C Min.: 1 Max.: 67
H1-02 (439H)	Multi-Function Digital Input Terminal S2 Function Selection	Term S2 Func Sel		Default: 3D Min.: 1 Max.: 67
H1-03 (400H)	Multi-Function Digital Input Terminal S3 Function Selection	Term S3 Func Sel		Default: 24H Min.: 0 Max.: 67
H1-04 (401H)	Multi-Function Digital Input Terminal S4 Function Selection	Term S4 Func Sel		Default: 14H Min.: 0 Max.: 67
H1-05 (402H)	Multi-Function Digital Input Terminal S5 Function Selection	Term S5 Func Sel		Default: F Min.: 0 Max.: 67
H1-06 (403H)	Multi-Function Digital Input Terminal S6 Function Selection	Term S6 Func Sel		Default: F Min.: 0 Max.: 67
H1-07 (404H)	Multi-Function Digital Input Terminal S7 Function Selection	Term S7 Func Sel		Default: F Min.: 0 Max.: 67
H1-08 (405H)	Multi-Function Digital Input Terminal S8 Function Selection	Term S8 Func Sel		Default: 8H Min.: 0 Max.: 67

<b>H1 Multi-Function Digital Input Selections</b>				
H1-□□ Setting	Function	LCD Display	Description	
1	LOCAL/REMOTE selection	Local/Remote Sel	Open: REMOTE (parameter settings determine the source of the frequency Reference 1 or 2 (b1-01, b1-02 or b1-15, b1-16) Closed: LOCAL, Frequency reference and Run command are input from the digital operator	
8	Baseblock command (N.O.)	Ext BaseBlk N.O.	Closed: No output	
9	Baseblock command (N.C.)	Ext BaseBlk N.C.	Open: No output	
C	Analog terminal input selection	Term A2 Enable	Open: Function assigned by H3-14 is disabled. Closed: Function assigned by H3-14 is enabled.	
F	Through mode	Term Not Used	Select this setting when using the terminal in a pass-through mode.	
14	Fault reset	Fault Reset	Closed: Resets faults if the cause is cleared and the Run command is removed.	
18	Timer function input	Timer function	Triggers the timer set up by parameters b4-01 and b4-02. Must be set in conjunction with the timer function output (H2-□□ = 12).	
1B	Program lockout	Program Lockout	Open: Parameters cannot be edited (except for U1-01 if the reference source is assigned to the digital operator). Closed: Parameters can be edited and saved.	

## B.2 Parameter Tables

H1 Multi-Function Digital Input Selections			
H1-□□ Setting	Function	LCD Display	Description
24 to 27 2C to 2F	External fault	External fault 24: NO/ Always Det, Coast to Stop 25: NC/Always Det, Coast to Stop 26: NO/During RUN, Coast to Stop 27: NC/During RUN, Coast to Stop 2C: NO/Always Det, Alarm Only 2D: NC/Always Det, Alarm Only 2E: NO/ During RUN, Alarm Only 2F: NC/During RUN, Alarm Only	24: N.O., Always detected, coast to stop 25: N.C., Always detected, coast to stop 26: N.O., During run, coast to stop 27: N.C., During run, coast to stop 2C: N.O., Always detected, alarm only (continue running) 2D: N.C., Always detected, alarm only (continue running) 2E: N.O., During run, alarm only (continue running) 2F: N.C., During run, alarm only (continue running)
3C	Forced Operation Command	Manual Run	Closed: Starts the operation of the regenerative unit.
3D	Automatic Operation Command	Auto Run	Closed: The regenerative unit starts to operate when the voltage of the bus increases (i.e., when a regenerative state is reached).
47	Node Setup	Node SetUp	Closed: Node setup for SI-S3 enabled.
67	Communications test mode	Comm Test Mode	Tests the MEMOBUS/Modbus RS-422/RS-485 interface. Displays "PASS" if the test completes successfully.



No. (Address Hex)	Name	LCD Display	Description	Values
<b>H2: Multi-Function Relay Outputs</b>				
H2-01 (40BH)	Terminal M1-M2 function selection (relay)	M1-M2 Func Sel	Refer to <a href="#">H2 Multi-Function Relay Output Settings on page 146</a> for a description of setting values. <b>Note:</b> Set unused terminals to F.	Default: 26 Min.: 0 Max.: 160
H2-02 (40CH)	Terminal M3-M4 Function Selection (Relay)	P1/PC Func Sel		Default: 6 Min.: 0 Max.: 160
H2-03 (40DH)	Terminal M5-M6 Function Selection (Relay)	P2/PC Func Sel		Default: 25 Min.: 0 Max.: 160
H2-06 (437H)	kWh Monitor Pulse Output Unit Selection	Pwr Mon Unit Sel 1: 1 kWh units 2: 10 kWh units 3: 100 kWh units 4: 1000 kWh units	Select the output unit of the multi-function contact when H2-01 to H2-03 is set to 3A. 1: 1 kWh 2: 10 kWh 3: 100 kWh 4: 1000 kWh	Default: 1 Min.: 1 Max.: 4

H2 Multi-Function Relay Output Settings			
H2-□□ Setting	Function	LCD Display	Description
0	During run	During RUN 1	Closed: A Run command is active or voltage is output.
6	Operation Ready	Drive Ready	Closed: Power up is complete and the regenerative unit is ready to accept a Run command.
7	DC bus undervoltage	DC Bus Undervolt	Closed: DC bus voltage is below the Uv trip level set in L2-05.
8	During baseblock (N.O.)	BaseBlk 1	Closed: Regenerative unit has entered the baseblock state (no regeneration).
E	Fault	Fault	Closed: Fault occurred.
F	Through mode	Not Used	Set this value when using the terminal in the pass-through mode.
10	Minor fault	Minor Fault	Closed: An alarm has been triggered.
11	Fault reset command active	Reset Cmd Active	Closed: A command has been entered to clear a fault via the input terminals or from the serial network.



H2 Multi-Function Relay Output Settings			
H2-□□ Setting	Function	LCD Display	Description
12	Timer output	Timer Output	Closed: Timer output.
1B	During baseblock (N.C.)	BaseBlk 2	Open: Regenerative unit has entered the baseblock state (no regeneration).
1D	During Regeneration	Regenerating	Closed: Motor is regenerating energy into the regenerative unit.
1E	Restart enabled	Dur Flt Restart	Closed: An automatic restart is performed
20	Heatsink Overheat (oH) pre-alarm	OH Prealarm	Closed: Heatsink temperature exceeds the parameter L8-02 value.
24	Fuse Blowout Detection	FUA/FUD Detect	Closed: Fuse burnout detected.
25	During Run 1	During RUN 1	Closed: The drive is ready to operate.
26	During MC ON	MC On	Closed: The magnetic contactor is closed.
27	Overload (oL2) Warning	OL2 Pre-alarm	Closed: There is an overload warning.
2F	Maintenance Period	Maintenance	Closed: It is time to perform maintenance on the cooling fan, electrolytic capacitor, and inrush prevention relay.
3A	kWh Monitor Pulse Output	Power (Produced)	Set the unit in H2-06. Multi-function output is ON for 200 ms depending on the unit selected in H2-06.
3B	Alarm 2	Minor Fault 2	Closed: Alarm occurred (excluding Uv, AUv, Fdv, SrC, and PAUv). <b>Note:</b> This setting is available in regenerative unit software versions PRG:2003 or later.
3C	LOCAL/REMOTE status	Local	Open: REMOTE Closed: LOCAL
4D	oH Pre-alarm time limit	OH Pre-Alarm	Closed: oH pre-alarm time limit has passed.
60	Internal cooling fan alarm	Fan Alrm Det	Closed: Internal cooling fan alarm
100 to 160	Function 0 to 60 with inverse output	–	Inverts the output switching of the multi-function output functions. Set the last two digits of 1□□ to reverse the output signal of that specific function.

No. (Address Hex)	Name	LCD Display	Description	Values
<b>H3: Multi-Function Analog Inputs</b>				
H3-01 (410H)	Terminal A1 Signal Level Selection	Term A1 Level 0: 0-10V, (LowLim=0) 1: 0-10V, (BipolRef)	0: 0 to 10 V 1: -10 to 10 V	Default: 0 Min.: 0 Max.: 1
H3-02 (434H)	Terminal A1 Function Selection	Term A1 FuncSel	Sets the function of terminal A1.	Default: F Min.: F Max.: F
H3-03 (411H)	Terminal A1 Gain Setting	Terminal A1 Gain	Sets the level of the input value selected in H3-02 when 10 V is input at terminal A1.	Default: 100.0% Min.: -999.9% Max.: 999.9%
H3-04 (412H)	Terminal A1 Bias Setting	Terminal A1 Bias	Sets the level of the input value selected in H3-02 when 0 V is input at terminal A1.	Default: 0.0% Min.: -999.9% Max.: 999.9%
H3-05 (413H)	Terminal A3 Signal Level Selection	Term A3 Signal 0: 0-10V (LowLim=0) 1: 0-10V (BipolRef)	0: 0 to 10 V 1: -10 to 10 V	Default: 0 Min.: 0 Max.: 1
H3-06 (414H)	Terminal A3 Function Selection	Terminal A3 Sel	Sets the function of terminal A3.	Default: F Min.: F Max.: F
H3-07 (415H)	Terminal A3 Gain Setting	Terminal A3 Gain	Sets the level of the input value selected in H3-06 when 10 V is input at terminal A3.	Default: 100.0% Min.: -999.9% Max.: 999.9%
H3-08 (416H)	Terminal A3 Bias Setting	Terminal A3 Bias	Sets the level of the input value selected in H3-06 when 0 V is input at terminal A3.	Default: 0.0% Min.: -999.9% Max.: 999.9%

## B.2 Parameter Tables

No. (Address Hex)	Name	LCD Display	Description	Values
H3-09 (417H)	Terminal A2 Signal Level Selection	Term A2 Level 0: 0-10V, (LowLim=0) 1: 0-10V, (BipolRef) 2: 4-20 mA 3: 0-20 mA	0: 0 to 10 V 1: -10 to 10 V 2: 4 to 20 mA 3: 0 to 20 mA <b>Note:</b> Use DIP switch S1 to set input terminal A2 for a current or a voltage input signal.	Default: 2 Min.: 0 Max.: 3
H3-10 (418H)	Terminal A2 Function Selection	Term A2 FuncSel	Sets the function of terminal A2.	Default: F Min.: F Max.: F
H3-11 (419H) 	Terminal A2 Gain Setting	Terminal A2 Gain	Sets the level of the input value selected in H3-10 when 10 V (20 mA) is input at terminal A2.	Default: 100.0% Min.: -999.9% Max.: 999.9%
H3-12 (41AH) 	Terminal A2 Bias Setting	Terminal A2 Bias	Sets the level of the input value selected in H3-10 when 0 V (0 or 4 mA) is input at terminal A2.	Default: 0.0% Min.: -999.9% Max.: 999.9%
H3-13 (41BH)	Analog Input Filter Time Constant	A1/A2 Filter T	Sets a primary delay filter time constant for terminals A1, A2, and A3. Used for electrical noise filtering.	Default: 0.03 s Min.: 0.00 s Max.: 2.00 s
H3-14 (41CH)	Analog Input Terminal Enable Selection	A1/A2 Sel 1: A1 Available 2: A2 Available 3: A1/A2 Available 4: A3 Available 5: A1/A3 Available 6: A2/A3 Available 7: All Available	Determines which analog input terminals will be enabled when a digital input programmed for "Analog input enable" (H1-□□ = C) is activated. 1: Terminal A1 only 2: Terminal A2 only 3: Terminals A1 and A2 only 4: Terminal A3 only 5: Terminals A1 and A3 6: Terminals A2 and A3 7: All terminals enabled	Default: 7 Min.: 1 Max.: 7

H3 Analog Output Settings			
H3-□□ Setting	Function	LCD Display	Description
F	Through mode	Through mode	Set this value when using the terminal in the pass-through mode.

No. (Address Hex)	Name	LCD Display	Description	Values
<b>H4: Analog Outputs</b>				
H4-01 (41DH)	Terminal FM Monitor Selection	Term FM FuncSel	Selects the data to be output through terminal FM. Set the desired monitor parameter to the digits available in U□-□□. For example, enter "154" for U1-54.	Default: 157 Min.: 000 Max.: 408
H4-02 (41EH) 	Terminal FM Monitor Gain	Terminal FM Gain	Sets the signal level at terminal FM that is equal to 100% of the selected monitor value.	Default: 100.0% Min.: -999.9% Max.: 999.9%
H4-03 (41FH) 	Terminal FM Monitor Bias	Terminal FM Bias	Sets the signal level at terminal FM that is equal to 0% of the selected monitor value.	Default: 0.0% Min.: -999.9% Max.: 999.9%
H4-04 (420H)	Terminal AM Monitor Selection	Terminal AM Sel	Selects the data to be output through terminal AM. Set the desired monitor parameter to the digits available in U□-□□. For example, enter "154" for U1-54.	Default: 155 Min.: 000 Max.: 408
H4-05 (421H) 	Terminal AM Monitor Gain	Terminal AM Gain	Sets the signal level at terminal AM that is equal to 100% of the selected monitor value.	Default: 50.0% Min.: -999.9% Max.: 999.9%



No. (Address Hex)	Name	LCD Display	Description	Values
H4-06 (422H) 	Terminal AM Monitor Bias	Terminal AM Bias	Sets the signal level at terminal AM that is equal to 0% of the selected monitor value.	Default: 0.0% Min.: -999.9% Max.: 999.9%
H4-07 (423H)	Terminal FM Signal Level Selection	Level Select1 0: 0-10 VDC 1: -10 +10 VDC 2: 4-20 mA	Sets the signal level at terminal FM. 0: 0 to 10 V 1: -10 to 10 V 2: 4 to 20 mA	Default: 0 Min.: 0 Max.: 1
H4-08 (424H)	Terminal AM Signal Level Selection	AO Level Select2 0: 0-10 VDC 1: -10 +10 VDC 2: 4-20 mA	Sets the signal level at terminal AM. 0: 0 to 10 V 1: -10 to 10 V 2: 4 to 20 mA	Default: 0 Min.: 0 Max.: 1
<b>H5: MEMOBUS/Modbus Serial Communication</b>				
<b>Note:</b> Restart the drive to enable MEMOBUS/Modbus communication settings.				
H5-01 (0425)	Drive Slave Address	Serial Comm Adr	Selects drive station node number (address) for MEMOBUS/Modbus terminals R+, R-, S+, S-. Cycle power for the setting to take effect.	Default: 1F (Hex) Min.: 0 Max.: FF
H5-02 (0426)	Communication Speed Selection	Serial Baud Rate 0: 1200 bps 1: 2400 bps 2: 4800 bps 3: 9600 bps 4: 19.2 kbps 5: 38.4 kbps 6: 57.6 kbps 7: 76.8 kbps 8: 115.2 kbps	0: 1200 bps 1: 2400 bps 2: 4800 bps 3: 9600 bps 4: 19200 bps 5: 38400 bps 6: 57600 bps 7: 76800 bps 8: 115200 bps Cycle power for the setting to take effect.	Default: 3 Range: 0 to 8
H5-03 (0427)	Communication Parity Selection	Serial Com Sel 0: No Parity 1: Even Parity 2: Odd Parity	0: No parity 1: Even parity 2: Odd parity Cycle power for the setting to take effect.	Default: 0 Range: 0 to 2
H5-04 (0428)	Stopping Method after Communication Error	Serial Fault Sel 0: Ramp to Stop 1: Coast to Stop 3: Alarm Only	0: Ramp to stop 1: Coast to stop 3: Alarm only	Default: 3 Range: 1, 3
H5-05 (0429)	Communication Fault Detection Selection	Serial Flt Dtet 0: Disabled 1: Enabled	0: Disabled 1: Enabled. If communication is lost for more than two seconds, a CE fault will occur.	Default: 1 Range: 0, 1
H5-06 (042A)	Drive Transmit Wait Time	Transmit WaitTIM	Set the wait time between receiving and sending data.	Default: 5 ms Min.: 5 Max.: 65
H5-07 (042B)	RTS Control Selection	RTS Control Sel 0: Disabled 1: Enabled	0: Disabled. RTS is always on. 1: Enabled. RTS turns on only when sending.	Default: 1 Range: 0, 1
H5-09 (0435)	Communications Fault Detection Time	CE Detect Time	Sets the time required to detect a communications error. Adjustment may be needed when networking several drives.	Default: 2.0 s Min.: 0.0 Max.: 10.0
H5-11 (043C)	Communications ENTER Function Selection	Enter CommandSel 0: Enter Required 1: No EnterRequired	0: Drive requires an Enter command before accepting any changes to parameter settings. 1: Parameter changes are activated immediately without the Enter command (same as V7).	Default: 1 Range: 0, 1

## B.2 Parameter Tables

### ◆ L: Protection Function

Protection function parameters set momentary power loss processing, fault retries, and hardware protection.

No. (Address Hex)	Name	LCD Display	Description	Values
<b>L2: Momentary Power Loss Ride-Thru</b>				
L2-01 (485H)	Momentary Power Loss Operation Selection	PwrL Selection 0: Disabled 1: Enbl with Timer 2: Enbl whl CPU act	0: Disabled. Regenerative unit trips on Uv1 fault when power is lost. 1: Recover within the time set in L2-02. Uv1 will be detected if power loss is longer than L2-02. 2: Recover as long as CPU has power. Uv1 is not detected. <b>Note:</b> Even if L2-01 is set to 1 or 2, the regenerative unit may detect a fault when momentary-power-loss occurs during regeneration or during no load.	Default: 0 Min.: 0 Max.: 2
L2-02 (486H)	Momentary Power Loss Ride-Thru Time	PwrL Ridethru t	Sets the Power Loss Ride-Thru time. Enabled only when L2-01 = 1 or 3.	Default: <> Min.: 0.0 s Max.: 25.5 s
L2-05 (489H)	Undervoltage Detection Level (Uv)	PUV Det Level	There is normally no need to change this parameter from the default value.	200 V Class Default: 190 V Min.: 150 V Max.: 210 V 400 V Class Default: 380 V Min.: 300 V Max.: 420 V
L2-21 (4D5H)	AUv Detection Level	AC UV Level	Sets the undervoltage detection level for power supply voltage (AC) in volts.	200 V Class Default: 150 V Min.: 100 V Max.: 200 V 400 V Class Default: 300 V Min.: 200 V Max.: 400 V
L2-38 (11E3H)	Power Supply Frequency Excessive Deviation Pre-alarm	pFDV DetectCount	Sets the number of times the regenerative unit detecting PFDv (Power Supply Frequency Excessive Deviation Pre-alarm). Disabled when set to 0.	Default: 4 Min.: 0 Max.: 30
<b>L5: Fault Restart</b>				
L5-01 (49EH)	Number of Auto Restart Attempts	Num of Restarts	Sets the number of times the regenerative unit may attempt to restart after the following faults occur: oC, oH1, oL2, ov, Uv1.	Default: 0 time Min.: 0 time Max.: 10 times
L5-02 (49FH)	Auto Restart Fault Output Operation Selection	Restart Sel 0: Flt Outp Disabl 1: Flt Outp Enabled	0: Fault output not active. 1: Fault output active during restart attempt.	Default: 0 Min.: 0 Max.: 1
L5-04 (4A0H)	Fault Reset Interval Time	Flt Reset Wait T	Sets the amount of time to wait between performing fault restarts.	Default: 10.0 s Min.: 0.5 s Max.: 600.0 s
L5-05 (46CH)	Fault Reset Operation Selection	Fault Reset Sel 0: Continuous 1: Use L5-04 Time	0: Continuously attempt to restart while incrementing restart counter only at a successful restart. 1: Attempt to restart with the interval time set in L5-04 and increment the restart counter with each attempt.	Default: 0 Min.: 0 Max.: 1
<b>L8: Drive Protection</b>				
L8-02 (4AEH)	Overheat Alarm Level	OH Pre-Alarm Lvl	An overheat alarm occurs when heatsink temperature exceeds the L8-02 level.	Default: <> Min.: 50°C Max.: 150°C
L8-03 (4AFH)	Overheat Pre-Alarm Operation Selection	OH Pre-Alarm Sel 0: Ramp to stop 3: Alarm only	0: Ramp to stop. A fault is triggered. 3: Continue operation. An alarm is triggered.	Default: 3 Min.: 1 Max.: 3

No. (Address Hex)	Name	LCD Display	Description	Values
L8-07 (4B3H)	Input Phase Loss (PF3) Protection Selection	Phase Loss Det	0: Disabled 1: Enabled	Default: 1 Min.: 0 Max.: 1
L8-10 (4B6H)	Heatsink Cooling Fan Operation Selection	Fan On/Off Sel 0: Dur Run (OffDly) 1: Always On	0: During run only. Fan operates only during run for L8-11 seconds after stop. 1: Fan always on. Cooling fan operates whenever the regenerative unit is powered up.	Default: 0 Min.: 0 Max.: 1
L8-11 (4B7H)	Heatsink Cooling Fan Off Delay Time	Fan Delay Time	Sets a delay time to shut off the cooling fan after the Run command is removed when L8-10 = 0.	Default: 60 s Min.: 0 s Max.: 300 s
L8-12 (4B8H)	Ambient Temperature Setting	Ambient Temp	Enter the ambient temperature. This value adjusts the oL2 detection level.	Default: 40°C Min.: -10°C Max.: 50°C
L8-35 (4ECH)	Installation Method Selection	Installation Sel 0: IP00/OpenChassis 1: Side-by-Side 2: IP20/NEMA Type 1 3: ExternalHeatsink	0: IP00 Open Type Enclosure 1: Side-by-Side Mounting 2: IP20/NEMA Type 1 3: External Heatsink Installation	Default: <2> Min.: 0 Max.: 3
L8-41 (4F2H)	High Current Alarm Selection	High Cur Alm Sel 0: Disabled 1: Enabled	0: Disabled 1: Enabled. An alarm is triggered at output currents above 150% of regenerative unit rated current.	Default: 0 Min.: 0 Max.: 1
L8-65 (66FH)	Power Supply Fault Detection Selection	Vpn Ripple Sel 0: Disabled 1: Coast to Stop 2: Alarm Only	There is normally no need to change this parameter from the default value. Monitors the ripple of DC BUS voltage and detects Input Power Supply Fault(PF2) when the ripple is too bad. 0: No detection 1: Stop operation (fault) 2: Continue operation (minor fault)	Default: 0 Min.: 0 Max.: 2
L8-66 (670H)	Power Supply Fault Detection Voltage Level	Vpn Ripple Lvl	There is normally no need to change this parameter from the default value. The main circuit DC voltage ripple is monitored in a cycle of 200 ms. If the difference between the maximum and minimum values of the ripple exceeds the value that is set in L8-66 for the number of times that is set in L8-67, a power supply fault is detected.	200 V Class Default: <2> Min.: 1 Max.: 200 400 V Class Default: <2> Min.: 1 Max.: 200
L8-67 (671H)	Number of Times of Power Supply Fault for Detection	Vpn Ripple Cnt		Default: 5 Min.: 1 Max.: 10
L8-69 (673H)	Input Phase Loss Protection Selection	AC Phase Imb Det 0: Disabled 1: Enabled	Sets whether to enable or disable the protective function for the regenerative unit when there is an input phase loss. 0: Disabled 1: Enabled (Detect input phase loss and power supply imbalance.)	Default: 1 Min.: 0 Max.: 1



<2> Default setting is dependent on parameter o2-04, Unit Model Selection.

## ◆ o: Operator-Related Settings

The o parameters set up the digital operator displays.

No. (Address Hex)	Name	LCD Display	Description	Values
<b>o1: Digital Operator Display Selection</b>				
o1-01 (500H) 	Drive Mode Monitor Selection	User Monitor Sel	When the power supply is turned on, the operator will display the following in order: DC Bus Voltage Feedback Reference, Input Voltage, Power Supply Current, Power Supply Power, Power Supply Frequency, and U1-□□. The o1-01 parameter sets the item to display instead of the output voltage. The o1-02 parameter sets the item to display at power up.	Default: 158 (Monitor U1-58) Min.: 110 Max.: 914

## B.2 Parameter Tables

No. (Address Hex)	Name	LCD Display	Description	Values
o1-02 (501H) 	User Monitor Selection after Power Up	Power-On Monitor 1: Frequency Ref 2: FWD/REV 3: Output Freq 4: Output Current 5: User Monitor	Selects the information displayed on the digital operator when the power is turned on. 1: Output Voltage Feedback 2: Input Voltage 3: Power Supply Current 4: Power Supply Power 5: User monitor item set in o1-01	Default: 1 Min.: 1 Max.: 5
o1-05 (504H)  <>	LCD Contrast Control	LCD Contrast	Sets the brightness of the LCD operator.	Default: 3 Min.: 0 Max.: 5
<b>o2: Digital Operator Keypad Functions</b>				
o2-01 (505H)	LO/RE Key Function Selection	LO/RE Key	0: Disabled 1: Enabled. LO/RE key switches between LOCAL and REMOTE operation.	Default: 1 Min.: 0 Max.: 1
o2-02 (506H)	STOP Key Function Selection	Oper STOP Key 0: Disabled 1: Enabled	0: Disabled. STOP key is disabled in REMOTE operation. 1: Enabled. STOP key is always enabled.	Default: 1 Min.: 0 Max.: 1
o2-03 (507H)	User Parameter Default Value	User Default Sel 0: No Change 1: Save User Init 2: Clear User Init	0: No change. 1: Set defaults. Saves parameter settings as default values for a User Initialization. 2: Clear all. Clears the default settings that have been saved for a User Initialization.	Default: 0 Min.: 0 Max.: 2
o2-04 (508H)	Unit Model Selection	Inverter Model #	Enter the regenerative unit model. Setting required only if installing a new control board.	Default: Determined by unit capacity. Min.: – Max.: –
o2-06 (50AH)	Operation Selection when Digital Operator is Disconnected	Oper Discon Det 0: Disabled 1: Enabled	Determines the operation when the digital operator is disconnected. 0: The regenerative unit continues operating if the digital operator is disconnected. 1: A fault is triggered (oPr) and the motor coasts to stop.	Default: 0 Min.: 0 Max.: 1
o2-09 (50DH)	Reserved	–	–	–
o2-21 (81AH)	Unit Check	US signal check 0: Nomal 1: Start	Sets the operation for Unit Capacity Setting Error (oPE01). Set this parameter to 1 to reset an oPE01 fault without cycling the power supply. 0: Standard 1: Recheck regenerative unit (The parameter returns to 0 after it is set.)	Default: 0 Min.: 0 Max.: 1
<b>o3: Copy Function</b>				
o3-01 (515H)	Copy Function Selection	COPY SELECT 0: COPY SELECT 1: INV→OP READ 2: OP→INV WRITE 3: OP←→INV VERIFY	0: No action 1: Read parameters from the regenerative unit, saving them onto the digital operator. 2: Copy parameters from the digital operator, writing them to the regenerative unit. 3: Verify parameter settings on the regenerative unit to check if they match the data saved on the operator.	Default: 0 Min.: 0 Max.: 3
o3-02 (516H)	Copy Allowed Selection	Read Allowable 0: Disabled 1: Enabled	0: Read operation prohibited 1: Read operation allowed	Default: 0 Min.: 0 Max.: 1
<b>o4: Maintenance Monitor Settings</b>				
o4-01 (50BH)	Cumulative Operation Time Setting	DrvElapsTimeCnt	Sets the value for the cumulative operation time of the regenerative unit in units of 10 h.	Default: 0 Min.: 0 Max.: 9999
o4-02 (50CH)	Cumulative Operation Time Selection	ElapsTimeCntSet 0: Power-On Time 1: Running Time	0: Logs power-on time 1: Logs operation time when the regenerative unit output is active (output operation time).	Default: 0 Min.: 0 Max.: 1

No. (Address Hex)	Name	LCD Display	Description	Values
o4-03 (50EH)	Cooling Fan Operation Time Setting	FanElapsTimeCn	Sets the value of the fan operation time monitor U4-03 in units of 10 h.	Default: 0 Min.: 0 Max.: 9999
o4-05 (51DH)	Capacitor Maintenance Setting	BusCap Maint Set	Sets the value of the Maintenance Monitor for the capacitors. See U4-05 to check when the capacitors may need to be replaced.	Default: 0% Min.: 0% Max.: 150%
o4-07 (523H)	DC Bus Pre-Charge Relay Maintenance Setting DC Bus Pre-Charge Relay Maintenance Setting	ChrgCircMaintSet	Sets the value of the Maintenance Monitor for the soft charge bypass relay. See U4-06 to check when the bypass relay may need to be replaced.	Default: 0% Min.: 0% Max.: 150%
o4-11 (510H)	U2, U3 Initialization	Fault Data Init 0: No Reset 1: Reset	0: U2-□□ and U3-□□ monitor data is not reset when the regenerative unit is initialized (A1-03). 1: U2-□□ and U3-□□ monitor data is reset when the regenerative unit is initialized (A1-03).	Default: 0 Min.: 0 Max.: 1
o4-12 (512H)	kWh Monitor Initialization	kWh Monitor Init 0: No Reset 1: Reset	0: U4-10 and U4-11 monitor data is not reset when the regenerative unit is initialized (A1-03). 1: U4-10 and U4-11 monitor data is reset when the regenerative unit is initialized (A1-03).	Default: 0 Min.: 0 Max.: 1
o4-13 (528H)	Number of Run Commands Counter Initialization	Run Counter Init 0: No Reset 1: Reset	0: Number of Run commands counter is not reset when the regenerative unit is initialized (A1-03). 1: Number of Run commands counter is reset when the regenerative unit is initialized (A1-03).	Default: 0 Min.: 0 Max.: 1
o4-19 (113AH)	Power Unit Price	Cost per 1 kWh	This parameter is used to calculate the power rate that is displayed for User Monitors U9-07 through U9-14. Set the price per 1 kWh.	Default: 000.00 Min.: 000.00 Max.: 650.00

<7> Parameter is available in software versions PRG: 2003 and later.

### ◆ U: Monitors

Monitor parameters allow the user to view regenerative unit status, fault information, and other data concerning regenerative unit operation.

No. (Address Hex)	Name	LCD Display	Description	Analog Output Level	Unit
<b>U1: Operation Status Monitors</b>					
U1-10 (49H)	Input Terminal Status	Input Term Sts	Displays the input terminal status.  <div style="text-align: center;"> <b>U1 - 10 = 00000000</b> </div> <div style="display: flex; justify-content: space-between;"> <div style="width: 40%;"> <p>1: ON 0: OFF</p> <ul style="list-style-type: none"> <li>└ Digital input 1 (terminal S1 enabled)</li> <li>└ Digital input 2 (terminal S2 enabled)</li> <li>└ Digital input 3 (terminal S3 enabled)</li> <li>└ Digital input 4 (terminal S4 enabled)</li> <li>└ Digital input 5 (terminal S5 enabled)</li> <li>└ Digital input 6 (terminal S6 enabled)</li> <li>└ Digital input 7 (terminal S7 enabled)</li> <li>└ Digital input 8 (terminal S8 enabled)</li> </ul> </div> <div style="width: 50%; text-align: right;"> <p>No signal output available</p> </div> </div>		-

## B.2 Parameter Tables

No. (Address Hex)	Name	LCD Display	Description	Analog Output Level	Unit
U1-11 (4AH)	Output Terminal Status	Output Term Sts	<p>Displays the output terminal status.</p> <p>U1-11=00000000</p> <p>1: ON 0: OFF</p> <ul style="list-style-type: none"> <li>Multi-Function Relay Output (terminal M1-M2)</li> <li>Multi-Function Relay Output (terminal M3-M4)</li> <li>Multi-Function Relay Output (terminal M5-M6)</li> <li>Reserved</li> <li>Fault Relay (terminal MA/MB-MC closed MA/MB-MC open)</li> </ul>	No signal output available	—
U1-12 (4BH)	Drive Status	Int Ctl Sts 1	<p>Verifies the regenerative unit operation status.</p> <p>U1-12=00000000</p> <ul style="list-style-type: none"> <li>Bit 0: During RUN</li> <li>Bit 1: Reserved</li> <li>Bit 2: Reserved</li> <li>Bit 3: Fault reset signal input</li> <li>Bit 4: Power supply established (0: Not completed, 1: Completed)</li> <li>Bit 5: Operation ready</li> <li>Bit 6: Minor fault detected</li> <li>Bit 7: Fault detected</li> </ul>	No signal output available	—
U1-13 (4EH)	Terminal A1 Input Level	Term A1 Level	Displays the signal level to analog input terminal A1.	10 V: 100%	0.1%
U1-14 (4FH)	Terminal A2 Input Level	Term A2 Level	Displays the signal level to analog input terminal A2.	10 V: 100%	0.1%
U1-15 (50H)	Terminal A3 Input Level	Term A3 Level	Displays the signal level to analog input terminal A3.	10 V: 100%	0.1%
U1-18 (61H)	oPE Fault Parameter	OPE Error Code	Displays the parameter number that caused the oPE02 or oPE08 operation error.	No signal output available	—
U1-19 (66H)	MEMOBUS/Modbus Error Code	Transmit Err	<p>Displays the contents of a MEMOBUS/Modbus error.</p> <p>U1-19=00000000</p> <ul style="list-style-type: none"> <li>1 CRC Error</li> <li>1 Data Length Error</li> <li>0 Not Used</li> <li>1 Parity Error</li> <li>1 Overrun Error</li> <li>1 Framing Error</li> <li>1 Timed Out</li> <li>0 Not Used</li> </ul>	No signal output available	—
U1-25 (4DH)	Software Number (Flash)	CPU 1 SW Number	FLASH ID	No signal output available	—
U1-26 (5BH)	Software No. (ROM)	CPU 2 SW Number	ROM ID	No signal output available	—
U1-27 (7A8H)	Message ID (OPR)	MessageID (OPR)	Shows the message ID number for OPE.	No signal output available	—
U1-28 (7A9H)	Message ID (INV)	MessageID (INV)	Shows the message ID number for INV.	No signal output available	—
U1-52 (1081H)	DC Bus Voltage Feedback	DC V Feedback	Shows the DC bus voltage feedback value.	200 V Class 10 V: 400 V 400 V Class 10 V: 800 V	1 V



No. (Address Hex)	Name	LCD Display	Description	Analog Output Level	Unit
U1-54 (1083H)	Power Supply Voltage	AC Voltage	Shows the power supply voltage.	200 V Class 10 V: 400 V 400 V Class 10 V: F800 V	1 V
U1-55 (1084H)	Power Supply Current	AC Current	Shows the current on the power supply side.	10 V: Rated Input Current	1 A
U1-57 (1086H)	Power Supply Side Power	AC Power	Shows the power on the power supply side.	10 V: Rated power (input side)	1 kW
U1-58 (1087H)	Power Supply Frequency	AC Frequency	Shows the frequency on the power supply side.	10 V: Rated Frequency	0.1 Hz
U1-72 (1095H)	Input Power Supply Information	AC Supply Status	Shows information on the input power supply.  <div style="display: flex; align-items: center;"> <div style="margin-right: 10px;"> <p><b>U1-72=00000000</b></p> </div> <div> <ul style="list-style-type: none"> <li>└ Bit 0: AUv reset. (0: Not completed, 1: Reset)</li> <li>└ Bit 1: PF3 reset (0: Not completed, 1: Reset)</li> <li>└ Bit 2: Rated frequency detection (0: Not completed, 1: Completed)</li> <li>└ Bit 3: Phase order detection (0: Not completed, 1: Completed)</li> <li>└ Bit 4: Power supply established (0: Not completed, 1: Completed)</li> <li>└ Bit 5: Fdv detection (0: Not detected, 1: Detected)</li> <li>└ Bit 6: PF3 detection (0: Not detected, 1: Detected)</li> <li>└ Bit 7: Reserved.</li> </ul> </div> </div>	No signal output available	—
U1-73 (1096H)	Voltage Deviation	V deviation	Shows the deviation between the DC bus voltage and the power supply voltage. Deviation = Bus voltage (U1-52) $\sqrt{2}$ – Power supply voltage (U1-54) If automatic operation is enabled, operation starts when the voltage increases to this value	No signal output available	1
<b>U2: Fault Trace</b>					
U2-01 (80H)	Current Fault	Current Fault	Displays the current fault.	No signal output available	—
U2-02 (81H)	Previous Fault	Last Fault	Displays the previous fault.	No signal output available	—
U2-11 (8AH)	Input Terminal Status at Previous Fault	Input Term Sts	Displays the input terminal status at the previous fault. Displayed as in U1-10.	No signal output available	—
U2-12 (8BH)	Output Terminal Status at Previous Fault	Output Term Sts	Displays the output status at the previous fault. Displays the same status displayed in U1-11.	No signal output available	—
U2-13 (8CH)	Drive Operation Status at Previous Fault	Inverter Status	Displays the operation status of the regenerative unit at the previous fault. Displays the same status displayed in U1-12.	No signal output available	—
U2-14 (8DH)	Cumulative Operation Time at Previous Fault	Elapsed time	Displays the cumulative operation time at the previous fault.	No signal output available	1 h
U2-20 (8EH)	Heatsink Temperature at Previous Fault	Actual Fin Temp	Displays the temperature of the heatsink when the most recent fault occurred.	No signal output available	1°C
U2-52 (841H)	DC Bus Voltage Feedback at Previous Fault	DC V Feedback	Shows the DC bus voltage feedback value.	No signal output available	1 V
U2-54 (843H)	Power Supply Voltage at Previous Fault	AC Voltage	Shows the power supply voltage.	No signal output available	1 V
U2-57 (846H)	Power Supply Side Power at Previous Fault	AC Power	Shows the power on the power supply side.	No signal output available	1 kW

Parameter List

## B.2 Parameter Tables

No. (Address Hex)	Name	LCD Display	Description	Analog Output Level	Unit
U2-58 (847H)	Power Supply Frequency at Previous Fault	AC Frequency	Shows the frequency on the power supply side.	No signal output available	0.1 Hz
U2-59 (848H)	Power Supply Side Current Reference at Previous Fault	AC Current Ref	Shows the current reference on the power supply side when the most recent fault occurred.	No signal output available	1 A
U2-60 (849H)	Power Factor at Previous Fault	Power Factor	Shows the power factor when the most recent fault occurred.	No signal output available	1%
U2-61 (84AH)	Active Current Reference at Previous Fault	Active Current	Shows the active current when the most recent fault occurred.	No signal output available	0.1%
U2-62 (84BH)	Reactive Current Reference at Previous Fault	Reactive Current	Shows the reactive current when the most recent fault occurred.	No signal output available	0.1%
U2-63 (84CH)	DC Bus Voltage Reference at Previous Fault (After SFS)	DC V SFS Level	Shows the DC bus voltage reference after the soft starter.	No signal output available	1 V
U2-64 (84DH)	Avr Input (Voltage Deviation) at Previous Fault	AVR Input	Shows the Avr input.	No signal output available	1 V
U2-65 (84EH)	Control Voltage Reference (Vq) at Previous Fault	Voltage Ref (Vq)	Shows the control voltage reference (Vq) when the most recent fault occurred.	No signal output available	1 V
U2-66 (84FH)	Control Voltage Reference (Vd) at Previous Fault	Voltage Ref (Vd)	Shows the control voltage reference (Vd) when the most recent fault occurred.	No signal output available	1 V
<b>U3: Fault History</b>					
U3-01 to U3-04 (90H to 93H)	First to 4th Most Recent Fault	Fault Message <input type="checkbox"/>	Displays the first to the fourth most recent faults.	No signal output available	–
U3-05 to U3-10 (804H to 809H)	5th to 10th Most Recent Fault	Fault Message <input type="checkbox"/>	Displays the fifth to the tenth most recent faults. After ten faults, data for the oldest fault is deleted. The most recent fault appears in U3-01, with the next most recent fault appearing in U3-02. The data is moved to the next monitor parameter each time a fault occurs.	No signal output available	–
U3-11 to U3-14 (94H to 97H)	Cumulative Operation Time at 1st to 4th Most Recent Fault	Elapsed Time <input type="checkbox"/>	Displays the cumulative operation time when the first to the fourth most recent faults occurred.	No signal output available	1 h
U3-15 to U3-20 (80EH to 813H)	Cumulative Operation Time at 5th to 10th Most Recent Fault	Elapsed Time <input type="checkbox"/>	Displays the cumulative operation time when the fifth to the tenth most recent faults occurred.	No signal output available	1 h
<b>U4: Maintenance Monitors</b>					
U4-01 (4CH) <->	Cumulative Operation Time	Drv Elapsed Time	Displays the cumulative operation time of the regenerative unit. The value for the cumulative operation time counter can be reset in parameter o4-01. Use parameter o4-02 to determine if the operation time should start as soon as the power is switched on or only while the Run command is present. The maximum number displayed is 99999, after which the value is reset to 0.	No signal output available	1 h
U4-02 (75H)	Number of Run Commands	RUN Cmd Counter	Displays the number of times the Run command is entered. Reset the number of Run commands using parameter o4-13. This value will reset to 0 and start counting again after reaching 65535.	No signal output available	1 time
U4-03 (67H) <->	Cooling Fan Operation Time	Fan Elapsed Time	Displays the cumulative operation time of the cooling fan. The default value for the fan operation time is reset in parameter o4-03. This value will reset to 0 and start counting again after reaching 99999.	No signal output available	1 h

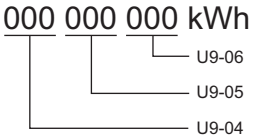
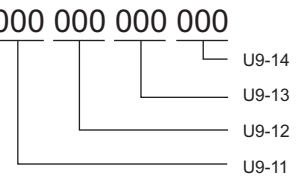

No. (Address Hex)	Name	LCD Display	Description	Analog Output Level	Unit
U4-04 (7EH)	Cooling Fan Maintenance	Fan Life Mon	Displays main cooling fan usage time as a percentage of its expected performance life. Parameter o4-03 can be used to reset this monitor. Replace the fan when this monitor reaches 90%.	No signal output available	1%
U4-05 (7CH)	Capacitor Maintenance	Cap Life Mon	Displays main circuit capacitor usage time as a percentage of their expected performance life. Parameter o4-05 can be used to reset this monitor. Replace the capacitor when this monitor reaches 90%.	No signal output available	1%
U4-06 (7D6H)	Soft Charge Bypass Relay Maintenance	ChgCirc Life Mon	Displays the soft charge bypass relay maintenance time as a percentage of its estimated performance life. Parameter o4-07 can be used to reset this monitor. Replace the soft charge bypass relay when this monitor reaches 90%.	No signal output available	1%
U4-08 (68H)	Heatsink Temperature	Heatsink Temp	Displays the heatsink temperature.	10 V: 100°C	1°C
U4-09 (5EH)	LED Check	LED Oper Check	Lights all segments of the LED to verify that the display is working properly.	No signal output available	–
U4-13 (7CFH)	Peak Hold Current	Current PeakHold	Displays the highest current value that occurred during run.	No signal output available	1 A
<b>U6: Operation Status Monitors</b>					
U6-80 to U6-99 (7B0H to 7F9H)	Option Monitors 1 to 20	–	Shows the monitor information for Option Monitor 1 (876 hex) to 20 (8FF hex). This information is displayed when option cards are connected. 200 V Class: 100% = 400 Vdc 400 V Class: 100% = 800 Vdc	No signal output available	–
<b>U9: Operation Status Monitors</b>					
U9-04 (823H)	Regenerative Power (GWh)	GWh Produced	Shows the total amount of regenerated power.  000 000 000 kWh 	0 to 999	1GWh
U9-05 (824H)	Regenerative Power (MWh)	MWh Produced		0 to 999	1MWh
U9-06 (825H)	Regenerative Power (kWh)	kWh Produced		0 to 999	1kWh
U9-11 to U9-14 (82AH to 82DH)	Regenerative Power Rates 1 to 4	Produced □ (\$)	These parameters show the regenerative power rate in Power Unit Price (o4-19) that is calculated from the total electrical power consumptions in U9-04 to U9-06.  000 000 000 000   The unit price is set in o4-19, and U9-11 to U9-14 are U9-04 to U9-06 times o4-19.	0 to 999	–

<4> The MEMOBUS/Modbus communications data is in 10 h units. If data in 1 h units are also required, refer to register number 0099H.

<5> The MEMOBUS/Modbus communications data is in 10 h units. If data in 1 h units are also required, refer to register number 009BH.

## B.3 Defaults by Unit Model

The following tables show parameters and default settings that change with o2-04 (Unit Model Selection).

**Table B.1 200 V Class Model Default Settings by Regenerative Unit Model Selection**

No.	Name		Unit	Default Settings											
	Model	–		2A03P5	2A0005	2A0007	2A0010	2A0014	2A0017	2A0020	2A0028	2A0035	2A0053	2A0073	2A0105
o2-04	Unit Model Selection		Hex	68	6A	6B	6D	6E	6F	70	72	73	75	76	78
C7-14	Bias Voltage at Operation Start		V	2.0	2.0	2.0	2.0	2.0	2.0	2.0	2.0	2.0	2.0	2.0	2.0
C7-15	Voltage Hysteresis Width at Operation Start/Stop		V	3.0	3.0	3.0	3.0	3.0	3.0	3.0	3.0	3.0	3.0	3.0	3.0
L2-02	Momentary Power Loss Ride-Thru Time		s	1.0	1.0	1.0	2.0	2.0	2.0	2.0	2.0	2.0	2.0	2.0	2.0
L2-05	Undervoltage Detection Level (Uv)		V	190	190	190	190	190	190	190	190	190	190	190	190
L2-21	AUv Detection Level		V	150	150	150	150	150	150	150	150	150	150	150	150
L8-02	Overheat Alarm Level		°C	85	105	110	115	115	120	120	120	110	115	110	120
L8-66	Power Supply Fault Detection Voltage Level		%	50	50	50	50	50	50	50	50	50	50	50	50
L8-35	Installation Method Selection		–	2	2	2	2	2	2	2	2	0	0	0	0

**Table B.2 400 V Class Model Default Settings by Regenerative Unit Model Selection**

No.	Name		Unit	Default Settings							
	Model	–		4A03P5	4A0005	4A0007	4A0010	4A0014	4A0017	4A0020	4A0028
o2-04	Unit Model Selection		Hex	97	99	9A	9C	9D	9E	9F	A1
C7-14	Bias Voltage at Operation Start		V	4.0	4.0	4.0	4.0	4.0	4.0	4.0	4.0
C7-15	Voltage Hysteresis Width at Operation Start/Stop		V	6.0	6.0	6.0	6.0	6.0	6.0	6.0	6.0
L2-02	Momentary Power Loss Ride-Thru Time		s	1.0	1.0	1.0	2.0	2.0	2.0	2.0	2.0
L2-05	Undervoltage Detection Level (Uv)		V	380	380	380	380	380	380	380	380
L2-21	AUv Detection Level		V	300	300	300	300	300	300	300	300
L8-02	Overheat Alarm Level		°C	80	85	100	95	110	105	115	110
L8-66	Power Supply Fault Detection Voltage Level		%	50	50	50	50	50	50	50	50
L8-35	Installation Method Selection		–	2	2	2	2	2	2	2	2

No.	Name		Unit	Default Settings							
	Model	–		4A0035	4A0043	4A0053	4A0073	4A0105	4A0150	4A0210	4A0300
o2-04	Unit Model Selection		Hex	A2	A3	A4	A5	A7	A9	AC	AE
C7-14	Bias Voltage at Operation Start		V	4.0	4.0	4.0	4.0	4.0	4.0	4.0	4.0
C7-15	Voltage Hysteresis Width at Operation Start/Stop		V	6.0	6.0	6.0	6.0	6.0	6.0	6.0	6.0
L2-02	Momentary Power Loss Ride-Thru Time		s	2.0	2.0	2.0	2.0	2.0	2.0	2.0	2.0
L2-05	Undervoltage Detection Level (Uv)		V	380	380	380	380	380	380	380	380
L2-21	AUv Detection Level		V	300	300	300	300	300	300	300	300
L8-02	Overheat Alarm Level		°C	110	115	115	110	110	110	140	140
L8-66	Power Supply Fault Detection Voltage Level		%	50	50	50	50	50	50	50	50
L8-35	Installation Method Selection		–	0	0	0	0	0	0	0	0

# Appendix: C

## MEMOBUS/Modbus Communications

---

C.1	MEMOBUS/MODBUS CONFIGURATION .....	160
C.2	COMMUNICATION SPECIFICATIONS .....	161
C.3	CONNECTING TO A NETWORK .....	162
C.4	MEMOBUS/MODBUS SETUP PARAMETERS .....	163
C.5	REGENERATIVE UNIT OPERATIONS BY MEMOBUS/MODBUS .....	165
C.6	COMMUNICATIONS TIMING .....	166
C.7	MESSAGE FORMAT .....	167
C.8	MESSAGE EXAMPLES .....	169
C.9	MEMOBUS/MODBUS DATA TABLE .....	171
C.10	ENTER COMMAND .....	181
C.11	COMMUNICATION ERRORS .....	182
C.12	SELF-DIAGNOSTICS .....	183

### C.1 MEMOBUS/Modbus Configuration

Regenerative unit can be controlled from a PLC or other master device via serial communications using the MEMOBUS/Modbus protocol.

MEMOBUS/Modbus communications can be configured using one master (PLC) and up to 255 slaves. The regenerative unit

has slave functionality only, and serial communication is normally initiated from the master and responded to by the slaves.

The master communicates with the specified slave regenerative unit. The address or node for each slave must be set prior so the master can communicate with the slave at that address. A slave that receives a command from the master will perform the specified function and send a response back to the master.

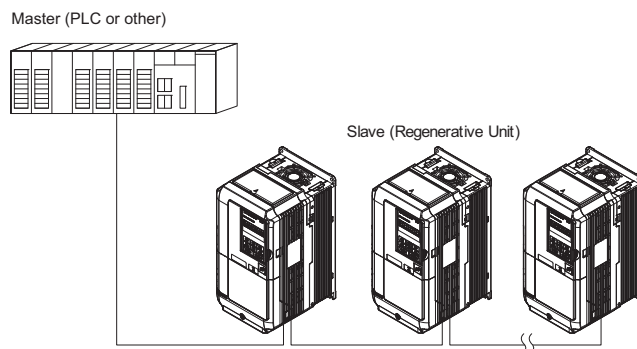

**Figure C.1 Connecting Multiple Regenerative Unit to a PLC**

## C.2 Communication Specifications

MEMOBUS/Modbus specifications appear in *Table C.1*:

**Table C.1 MEMOBUS/Modbus Communications Specifications**

Item	Specifications	
Interface	RS-422, RS-485	
Communications Cycle	Asynchronous (Start-stop synchronization)	
Communication Parameters	Communication Speeds Available	1.2; 2.4; 4.8; 9.6; 19.2; 38.4; 57.6; 76.8; 115.2 kbps
	Data length	8-bit (fixed)
	Parity	Select even, odd, or none
	Stop bit	1-bit (fixed)
Protocol	MEMOBUS/Modbus (using RTU mode only)	
Max Number of Slaves	31 regenerative units (RS-485)	

## C.3 Connecting to a Network

This section explains how to connect the regenerative unit to a MEMOBUS/Modbus network and the network termination required for a connection.

### ◆ Network Cable Connection

Follow the instructions below to connect the regenerative unit to a MEMOBUS/Modbus network.

1. With the power shut off, connect the communications cable to the regenerative unit and the master. Use terminals TB5 for MEMOBUS/Modbus.

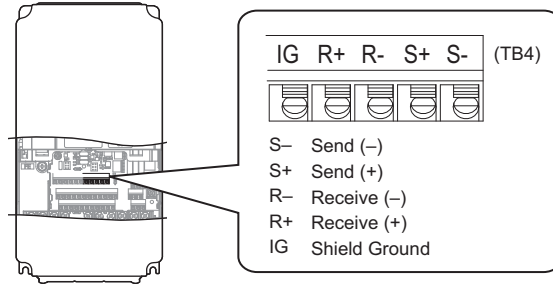

Figure C.2 Serial Communications Cable Connection Terminals (TB4)

**Note:** Separate the communications cables from the main circuit cables and other wiring and power cables. Use shielded cables for the communications cables, and properly shielded clamps to prevent problems with electrical noise. When using RS-485 communications, connect S+ to R+, and S- to R- as shown in the diagram below.

2. Check or set the termination resistor selection at all slaves. Use the description in [Network Termination on page 162](#) for slaves that are regenerative units.
3. Switch the power on.
4. Set the parameters needed for serial communications (H5-01 through H5-12) using the digital operator.
5. Shut the power off and wait until the display on the digital operator goes out completely.
6. Turn the power back on.
7. The regenerative unit is now ready to begin communicating with the master.

### ◆ Network Termination

The two ends of the MEMOBUS/Modbus network line have to be terminated. The regenerative unit has a built in termination resistor that can be enabled or disabled using DIP switch S2. If a regenerative unit is located at the end of a network line, enable the termination resistor by setting DIP switch S2 to the ON position. Disable the termination resistor on all slaves that are not located at the network line end.

To set the DIP switch, use tweezers or a tool with a tip width of approximately 0.8 mm.

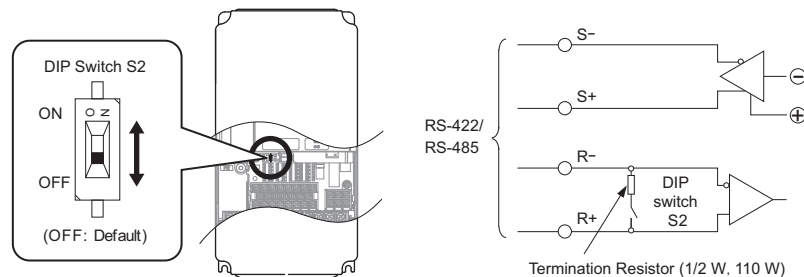

Figure C.3 Communication Terminals and DIP Switch S2

## C.4 MEMOBUS/Modbus Setup Parameters

### ◆ MEMOBUS/Modbus Serial Communication

This section describes parameters necessary to set up MEMOBUS/Modbus communications.

#### ■ H5-01: Drive Slave Address

Sets the regenerative unit slave address used for communications.

**Note:** Cycle the power after changing this parameter to enable the new setting.

No.	Name	Setting Range	Default
H5-01	Drive Slave Address	0 to FFH <1>	1FH

<1> If the address is set to 0, no response will be provided during communications.

Each slave regenerative unit must be assigned a unique slave address for serial communications to work. Setting H5-01 to any value besides 0 assigns the regenerative unit its address in the network. Slave addresses do not need to be assigned in sequential order, but no two regenerative units may share the same address.

#### ■ H5-02: Communication Speed Selection

Sets the MEMOBUS/Modbus communications speed.

**Note:** Cycle the power after changing this parameter to enable the new setting.

No.	Name	Setting Range	Default
H5-02	Communication Speed Selection	0 to 8	3

**Setting 0: 1200 bps**

**Setting 1: 2400 bps**

**Setting 2: 4800 bps**

**Setting 3: 9600 bps**

**Setting 4: 19200 bps**

**Setting 5: 38400 bps**

**Setting 6: 57600 bps**

**Setting 7: 76800 bps**

**Setting 8: 115200 bps**

#### ■ H5-03: Communication Parity Selection

Sets the parity used for communications.

**Note:** Cycle the power after changing this parameter to enable the new setting.

No.	Name	Setting Range	Default
H5-03	Communication Parity Selection	0 to 2	0

**Setting 0: No parity**

**Setting 1: Even parity**

**Setting 2: Odd parity**

#### ■ H5-04: Stopping Method after Communication Error

Selects the stopping method after a communications error (CE) has occurred.

No.	Name	Setting Range	Default
H5-04	Stopping Method after CE	1, 3	3

**Setting 1: Stop operation**

**Setting 3: Alarm only (continue operation)**

## C.4 MEMOBUS/Modbus Setup Parameters

### ■ H5-05: Communication Fault Detection Selection

Enables or disables the CE detection for communications.

No.	Name	Setting Range	Default
H5-05	Communication Fault Detection Selection	0 or 1	1

#### Setting 0: Disabled

No communication error detection. The regenerative unit continues operation.

#### Setting 1: Enabled

If the regenerative unit does not receive data from the master for longer than the time set to H5-09, then a CE fault will be triggered and the regenerative unit will operate as determined by parameter H5-04.

### ■ H5-06: Drive Transmit Wait Time

Sets the time the regenerative unit waits after receiving data from a master until responding data.

No.	Name	Setting Range	Default
H5-06	Drive Transmit Wait Time	5 to 65 ms	5 ms

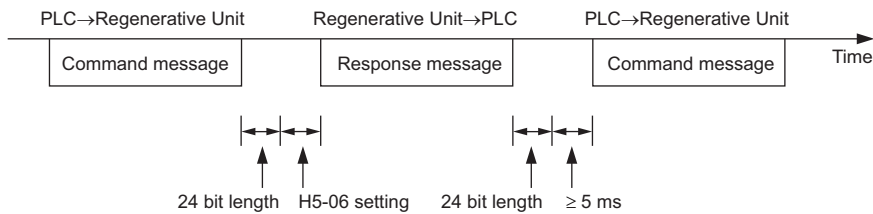

Figure C.4 Regenerative Unit Transmit Wait Time Setting

### ■ H5-07: RTS Control Selection

Enables or disables RTS control.

No.	Name	Setting Range	Default
H5-07	RTS Control Selection	0 or 1	1

#### Setting 0: Disabled. RTS is always on.

Use this setting with point-to-point or multi-drop RS-422 communications.

#### Setting 1: Enabled. RTS switches while sending.

Use this setting when using RS-485 signals for communications or when using the RS-422 signals for point-to-point communications.

### ■ H5-09: Communications Fault Detection Time

Sets the time the communications must be lost before the regenerative unit triggers a CE fault.

No.	Name	Setting Range	Default
H5-09	Communications Fault Detection Time	0.0 to 10.0 s	2.0 s

### ■ H5-11: Communications Enter Function Selection

Selects whether an Enter command is necessary to change parameter values via MEMOBUS/Modbus communications. Refer to [Enter Command on page 181](#).

No.	Name	Setting Range	Default
H5-11	Communications Enter Function Selection	0 or 1	1

#### Setting 0: Enter command necessary

Parameter changes become effective after an Enter command. An Enter command must only be sent after the last parameter change, not for each single parameter.

#### Setting 1: Enter command not necessary

Parameter value changes become effective immediately without the need to send an Enter command.



## C.5 Regenerative Unit Operations by MEMOBUS/Modbus

The regenerative unit operations that can be performed by MEMOBUS/Modbus communication depend on regenerative unit parameter settings. This section explains the functions that can be used and related parameter settings.

### ◆ Observing the Regenerative Unit Operation

A PLC can perform the following actions with MEMOBUS/Modbus communications at any time regardless of parameter settings (except for H5-□□ parameters):

- observe regenerative unit status and regenerative unit control terminal status from a PLC.
- read and write parameters.
- set and reset faults.
- set multi-function inputs.

**Note:** Input settings from the input terminals (S1 to S8) and from MEMOBUS/Modbus communications are both linked by a logical OR operation.

### ◆ Controlling the Regenerative Unit

Adjust the parameter in [Table C.2](#) accordingly to start and stop the regenerative unit using MEMOBUS/Modbus communications.

**Table C.2 Setting Parameters for Regenerative Unit Control from MEMOBUS/Modbus**

Reference Source	Parameter	Name	Required Setting
External Reference 1	b1-02	Run Command Selection 1	2

Refer to [b1-02 \(181H\) on page 142](#) for details.

## C.6 Communications Timing

To prevent a communications overrun in the slave regenerative unit, the master should wait a certain time between sending messages to the same regenerative unit. In the same way, the slave regenerative unit must wait before sending response messages to prevent an overrun in the master. This section explains the message timing.

### ◆ Command Messages from Master to Regenerative Unit

The master must wait for a specified time between receiving a response and resending the same type of command to the same slave regenerative unit to prevent overrun and data loss. The minimum wait time depends on the command as shown in [Table C.3](#).

**Table C.3 Minimum Wait Time for Sending Messages**

Command Type	Example	Minimum Wait Time
1	<ul style="list-style-type: none"> <li>Control command (Run, Stop)</li> <li>Set inputs/outputs</li> <li>Read monitors and parameter values</li> </ul>	5 ms <1>
2	Write parameters	H5-11 = 0: 50 ms H5-11 = 1: 200 ms <1>
3	Save changes using an Enter command	200 ms to 2 s, depending on the number of parameters that were changed <1>

<1> If the regenerative unit receives command type 1 data during the minimum wait time, it will perform the command and then respond. However, if it receives a command type 2 or 3 during that time, either a communication error will result or the command will be ignored.

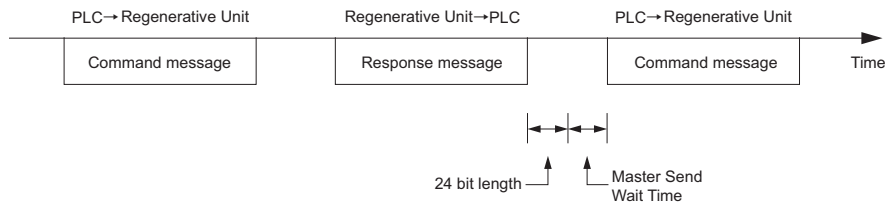
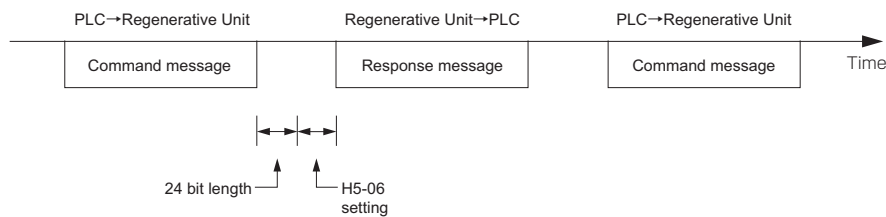

**Figure C.5 Minimum Wait Time for Sending Messages**

Set a timer in the master to check how long it takes for the slave regenerative unit(s) to respond to the master. If no response is received within a certain amount of time, the master should try resending the message.

### ◆ Response Messages from Regenerative Unit to Master

If the slave regenerative unit receives a command from the master, it will process the data received and wait for the time set in H5-06 until it responds. Increase H5-06 if the regenerative unit response causes overrun in the master.



**Figure C.6 Minimum Response Wait Time**

## C.7 Message Format

### ◆ Message Content

In MEMOBUS/Modbus communications, the master sends commands to the slave, and the slave responds. The message format is configured for both sending and receiving as shown below, and the length of data packets depends on the command (function) content.

SLAVE ADDRESS
FUNCTION CODE
DATA
ERROR CHECK

### ◆ Slave Address

The slave address in the message defines the node the message is sent to. Use addresses between 0 and FF (hex). If a message with slave address 0 is sent (broadcast), the command from the master will be received by all slaves. The slaves do not provide a response to a broadcast type message.

### ◆ Function Code

The three types of function codes are shown in the table below.

Function Code	Function Name	Data Length (bytes)			
		Command Message		Response Message	
		Minimum	Maximum	Minimum	Maximum
03H	Read MEMOBUS/Modbus registers	8	8	7	37
08H	Loopback test	8	8	8	8
10H	Write to multiple MEMOBUS/Modbus registers	11	41	8	8

### ◆ Data

Configure consecutive data by combining the MEMOBUS/Modbus register address (test code in case of a loopback test) and the data the register contains. The data length changes depending on the command details.

A regenerative unit MEMOBUS/Modbus register always has a data length of two bytes. Data written into regenerative unit registers must also always have a length of two bytes. Register data read out from the regenerative unit will always consist of two bytes.

◆ Error Check

The regenerative unit uses a CRC-16 (cyclic redundancy check, checksum method) for checking data validity. Use the procedure described below when calculating the CRC-16 checksum for command data or when verifying response data.

■ Command Data

When the regenerative unit receives data, it calculates the CRC-16 checksum from the data and compares it to the CRC-16 value received within the message. Both must match before a command is processed.

An initial value of FFFFH (i.e., all 16 bits equal 1) must be used for CRC-16 calculations in the MEMOBUS/Modbus protocol.

Calculate the CRC-16 checksum using the following steps:

1. The starting value is FFFFH.
2. Perform an XOR operation of this value and the slave address.
3. Right shift the result.
4. When the overflow bit of the shift operation becomes 1, perform an XOR operation of the result from step 3 above and the fix value A001H.
5. Repeat steps 3 and 4 until eight shift operations have been performed.
6. After eight shift operations, perform an XOR operation with the result and the next data in the message (function code, register address, data). Continue with steps 3 to 5 until the last data has been processed.
7. The result of the last shift or XOR operation is the checksum.

The example in [Table C.4](#) shows the CRC-16 calculation of the slave address 02H and the function code 03H, yielding the result D140H.

**Note:** This example does not show the calculation for a complete MEMOBUS/Modbus command. Normally data would follow in the calculation.

**Table C.4 CRC-16 Checksum Calculation Example**

Description	Calculation	Overflow	Description	Calculation	Overflow
Initial Value (FFFFH)	1111 1111 1111 1111		Function Code 03H	0000 0011	
Address 02H	0000 0010		XOR w result	1000 0001 0011 1101	
XOR w initial value	1111 1111 1111 1101		Shift 1	0100 0000 1001 1110	1
Shift 1	0111 1111 1111 1110	1	XOR w A001H	1010 0000 0000 0001	
XOR w A001H	1010 0000 0000 0001		XOR result	1110 0000 1001 1111	
XOR result	1101 1111 1111 1111		Shift 2	0111 0000 0100 1111	1
Shift 2	0110 1111 1111 1111	1	XOR w A001H	1010 0000 0000 0001	
XOR w A001H	1010 0000 0000 0001		XOR result	1101 0000 0100 1110	
XOR result	1100 1111 1111 1110		Shift 3	0110 1000 0010 0111	0
Shift 3	0110 0111 1111 1111	0	Shift 4	0011 0100 0001 0011	1
Shift 4	0011 0011 1111 1111	1	XOR w A001H	1010 0000 0000 0001	
XOR w A001H	1010 0000 0000 0001		XOR result	1001 0100 0001 0010	
XOR result	1001 0011 1111 1110		Shift 5	0100 1010 0000 1001	0
Shift 5	0100 1001 1111 1111	0	Shift 6	0010 0101 0000 0100	1
Shift 6	0010 0100 1111 1111	1	XOR w A001H	1010 0000 0000 0001	
XOR w A001H	1010 0000 0000 0001		XOR result	1000 0101 0000 0101	
XOR result	1000 0100 1111 1110		Shift 7	0100 0010 1000 0010	1
Shift 7	0100 0010 0111 1111	0	XOR w A001H	1010 0000 0000 0001	
Shift 8	0010 0001 0011 1111	1	XOR result	1110 0010 1000 0011	
XOR w A001H	1010 0000 0000 0001		Shift 8	0111 0001 0100 0001	1
XOR result	1000 0001 0011 1110		XOR w A001H	1010 0000 0000 0001	
			XOR result	1101 0001 0100 0000	
				1101 0001 0100 0000	
			CRC-16	D 1 4 0	
				Lower Upper	
			Continue from here with next data.		

■ Response Data

Perform a CRC-16 calculation on the response message data as described above as a validation check. The result should match the CRC-16 checksum received within the response message.

## C.8 Message Examples

Below are some examples of command and response messages.

### ◆ Reading Regenerative Unit MEMOBUS/Modbus Register Contents

Using the function code 03H (Read), a maximum of 16 MEMOBUS/Modbus registers can be read out at a time.

The following table shows message examples when reading error details and data link status from the slave 2 regenerative units.

Command Message			Response Message (normal)		
Slave Address		02H	Slave Address		02H
Function Code		03H	Function Code		03H
Starting No.	Upper	00H	Data Quantity		04H
	Lower	21H	1st storage register	Upper	00H
Data Quantity	Upper	00H		Lower	00H
	Lower	02H	Next storage register	Upper	00H
Upper		94H		Lower	00H
CRC-16	Lower	32H	CRC-16	Upper	C9H
				Lower	33H

### ◆ Loopback Test

Function code 08H performs a loopback test that returns a response message with exactly the same content as the command message. The response message can be used to check communications between the master and slave. User-defined test code and data values can also be set.

The following table shows a message example when performing a loopback test with the slave 1 regenerative unit.

Command Message			Response Message (normal)			Response Message (fault)		
Slave Address		01H	Slave Address		01H	Slave Address		01H
Function Code		08H	Function Code		08H	Function Code		88H
Test Code	Upper	00H	Test Code	Upper	00H	Error Code		01H
	Lower	00H		Lower	00H	CRC-16	Upper	86H
Data	Upper	A5H	Data	Upper	A5H		Lower	50H
	Lower	37H		Lower	37H			
CRC-16	Upper	DAH	CRC-16	Upper	DAH			
	Lower	8DH		Lower	8DH			

◆ Writing to Multiple Registers

Function code 10H allows the user to write multiple regenerative unit MEMOBUS/Modbus registers with one message. This process works similar to reading registers, in that the address of the first register to be written and the data quantity are set in the command message. The data to be written must be consecutive so that the register addresses are in order, starting from the specified address in the command message. The data order must be high byte then lower byte.

The following table shows an example of a message where 2000H has been set with a Multi-Function Analog Output 1 and 4000H has been set with a Multi-Function Analog Output 2 for the slave 1 regenerative unit.

If parameter values are changed using the Write command, an Enter command may be necessary to activate or save the data depending on the setting of H5-11. Refer to [H5-11: Communications Enter Function Selection on page 164](#) and Refer to [Enter Command on page 181](#) for detailed descriptions.

Command Message			Response Message (normal)		
Slave Address		01H	Slave Address		01H
Function Code		10H	Function Code		10H
Starting No.	Upper	00H	Starting No.	Upper	00H
	Lower	07H		Lower	07H
Data Quantity	Upper	00H	Data Quantity	Upper	00H
	Lower	02H		Lower	02H
Number of Bytes		04H	CRC-16	Upper	F0H
Starting Data	Upper	20H		Lower	09H
	Next Data	Lower	00H		
CRC-16		Upper	40H		
	Lower	00H			
	Upper	88H			
	Lower	49H			

**Note:** Double the number of the data quantity for the number of bytes in the command message.

## C.9 MEMOBUS/Modbus Data Table

The table below lists all MEMOBUS/Modbus data. There are three types of data: command data, monitor data, and broadcast data.

### ◆ Command Data

It is possible to both read and write command data.

**Note:** Bits that are not used should be set to 0. Refrain from writing to reserved registers.

Register No.	Contents		
0000H	Reserved		
0001H	Operation Commands and Multi-function Inputs		
	bit 0	Run/Stop 1: Automatic operation command 0: Stop	
	bit 1	Run/Stop 1: Forced operation command 0: Stop	
	bit 2	External Fault (EF0)	
	bit 3	Fault Reset	
	bit 4	Multi-Function Input 1	
	bit 5	Multi-Function Input 2	
	bit 6	Multi-Function Input 3	
	bit 7	Multi-Function Input 4	
	bit 8	Multi-Function Input 5	
	bit 9	Multi-Function Input 6	
	bit A	Multi-Function Input 7	
	bit B	Multi-Function Input 8	
bit C - bit F	Reserved		
0002H - 0003H	Reserved		
0004H	Active Current Limit (Positive) 100.0%/1000		
0005H - 0006H	Reserved		
0007H	Analog Output Terminal FM Setting (10 V / 4000 H)		
0008H	Analog Output Terminal AM Setting (10 V / 4000 H)		
0009H	Settings for Multi-Function Relay Outputs		
	bit 0	Multi-Function Relay Output 1 (terminal M1-M2)	
	bit 1	Multi-Function Relay Output 1 (terminal M3-M4)	
	bit 2	Multi-Function Relay Output 2 (terminal M5-M6)	
	bit 3 - bit 5	Reserved	
	bit 6	Enables the function in bit 7	
	bit 7	Fault Contact Output (terminal MA/MB-MC)	
bit 8 - bit F	Reserved		
000AH - 000DH	Reserved		
000EH	Active Current Limit (Negative) 100.0%/1000		
000FH - 001AH	Reserved		
001BH	Analog Monitor Option AO-A3 Analog Output 1 (10 V/4000 H)		
001CH	Analog Monitor Option AO-A3 Analog Output 2 (10 V/4000 H)		
001DH	Digital Output Option DO-A3 Output (Binary)		
001EH - 001FH	Reserved		

**◆ Monitor Data**

Monitor data can be read only.

Register No.	Contents	
0020H	Unit Status 1	
	bit 0	During Run
	bit 1	Reserved
	bit 2	Operation Ready
	bit 3	Fault
	bit 4	Data Setting Error
	bit 5	Multi-Function Relay Output (terminal M1-M2)
	bit 6	Multi-Function Relay Output 1 (terminal M3-M4)
	bit 7	Multi-Function Relay Output 2 (terminal M5-M6)
bit 8 - bit F	Reserved	
0021H	Fault Contents 1	
	bit 0	Overcurrent (oC)
	bit 1	Overvoltage (ov)
	bit 2	Overload (oL2)
	bit 3	Overheat 1 (oH1), Overheat 2 (oH2)
	bit 4 - bit 6	Reserved
	bit 7	EF to EF8: External Fault
	bit 8	CPF□□: Hardware Fault (includes oF□)
	bit 9 - bit A	Reserved
	bit B	Main Circuit Undervoltage (Uv)
	bit C	Undervoltage (Uv1), Control Power Supply Undervoltage (Uv2), Soft Charge Circuit Fault (Uv3)
	bit D	Output Phase Loss (LF), Input Phase Loss (PF)
bit E	MEMOBUS/Modbus Communication Error (CE), Option Communication Error (bUS)	
bit F	Operator Connection Fault (oPr)	
0022H	Data Link Status	
	bit 0	Writing data or switching motors
	bit 1 - bit 2	Reserved
	bit 3	Upper or lower limit error
	bit 4	Data conformity error
	bit 5	Writing to EEPROM
bit 6 - bit F	Reserved	
0023H - 0028H	Reserved	
0029H	Fault Contents 2	
	bit 0 - bit F	Reserved
002AH	Alarm Contents 1	
	bit 0 - bit 2	Reserved
	bit 3	Baseblock (bb)
	bit 4	Reserved
	bit 5	Heatsink Overheat (oH)
	bit 6	Overvoltage (ov)
	bit 7	Undervoltage (Uv)
	bit 8	Cooling Fan Error (Fan)
	bit 9	MEMOBUS/Modbus Communication Error (CE)
	bit A	Option Communication Error (bUS)
	bit B - bit E	Reserved
bit F	Serial Communication Transmission Error (CALL)	



Register No.	Contents	
002BH	Input Terminal Status	
	bit 0	Terminal S1 Closed
	bit 1	Terminal S2 Closed
	bit 2	Terminal S3 Closed
	bit 3	Terminal S4 Closed
	bit 4	Terminal S5 Closed
	bit 5	Terminal S6 Closed
	bit 6	Terminal S7 Closed
	bit 7	Terminal S8 Closed
	bit 8 - bit F	Reserved
002CH	Drive Status 2	
	bit 0	During Run
	bit 1 - bit 5	Reserved
	bit 6	Drive Ready
	bit 7	During Undervoltage
	bit 8	During Baseblock
	bit 9	Reserved
	bit A	Run Command from Operator Keypad
	bit B - bit C	Reserved
	bit D	During Fault Restart
	bit E	Fault
bit F	Communication Timeout	
002DH	Output Terminal Status	
	bit 0	Multi-Function Relay Output 1 (terminal M1-M2)
	bit 1	Multi-Function Relay Output 1 (terminal M3-M4)
	bit 2	Multi-Function Relay Output 2 (terminal M5-M6)
	bit 3 - bit 6	Reserved
	bit 7	Fault Contact Output (terminal MA/MB-MC)
	bit 8 - bit F	Reserved
002EH	Unit Status	
	bit 0	1: During Run 0: During Stop
	bit 2	1: During Regenerative Operation
	bit 3	1: During Reset Signal Input
	bit 4	1: During Run 1 (Operation Ready)
	bit 5	1: Operation Ready
	bit 6	1: Alarm
	bit 7	1: Fault
	bit 8	1: oPE Error
	bit 9	1: Momentary Power Loss Ridethru 0: Recovery from Momentary Power Loss
bit A	1: ComCtrl status/NetCtrl status	
bit D	1: During Active Current Limit	
002FH - 0033H	Reserved	
0034H	Product Code 1 [ASCII], Product Type (R1000 = DA)	
0035H	Product Code 2 [ASCII], Region Code	
0036H - 003CH	Reserved	
003DH	Communications Error Contents <I>	
	bit 0	CRC Error
	bit 1	Data Length Error
	bit 2	Reserved
	bit 3	Parity Error
	bit 4	Overrun Error
	bit 5	Framing Error
	bit 6	Timeout
	bit 7 to bit F	Reserved
003EH - 003FH	Reserved	
0040H - 004AH	Used for various monitors U1-□□. Refer to <i>U: Monitors on page 153</i> for parameter details.	

## C.9 MEMOBUS/Modbus Data Table

Register No.	Contents	
004BH	Unit status (U1-12)	
	bit 0	During Run
	bit 1 - bit 2	Reserved
	bit 3	During Fault Reset Signal Input
	bit 4	Not Used
	bit 5	Operation Ready
	bit 6	Alarm
	bit 7	Fault
	bit 8 - bit B	Reserved
	bit E	ComRef status, NetRef status
bit F	ComCtrl status, NetCtrl status	
004CH - 007EH	Used for various monitors U1-□□, U4-□□, U5-□□ and U6-□□. Refer to <a href="#">U2: Fault Trace on page 155</a> and <a href="#">U3: Fault History on page 156</a> for parameter details.	
007FH	Alarm Code, Refer to <a href="#">Alarm Register Contents on page 180</a> for alarm codes.	
0080H - 0097H	Used for monitors U2-□□, U3-□□. Refer to <a href="#">U: Monitors on page 153</a> for parameter details and Refer to <a href="#">Fault Trace Contents on page 179</a> for register value descriptions.	
0098H	High Word of Accumulated Operation Time Monitor, 10 h units (U4-01)	
0099H	Low Word of Accumulated Operation Time Monitor, 1 h units (U4-01)	
009AH	High Word of Cooling Fan Operation Time Monitor (U4-03)	
009BH	Low Word of Cooling Fan Operation Time Monitor (U4-03)	
009CH - 00AFH	Reserved	
00B0H	Option Code Connected to CN5-A	Register contains ASCII code of the option card. DO-A3 = 0002H AI-A3 = 0003H AO-A3 = 0004H Communication Option: Register contains ASCII code of first and third digit of the option card type number. Example: Register value is 5343H for "SC" if an SI-C3 option card is installed.
00B1H	Reserved	
00B2H	Option Code Connected to CN5-B	
00B3H	Option Code Connected to CN5-C	
00B4H - 00BEH	Reserved	
00BFH	Lists the last two digits of operation error code oPE□□.	
00C0H	Fault Contents 3	
	bit 0	DC Fuse Blowout (PUF)
	bit 1	Undervoltage (Uv1)
	bit 2	Control Power Supply Undervoltage (Uv2)
	bit 3	Soft Charge Circuit Fault (Uv3)
	bit 4	IGBT Short Circuit (SC)
	bit 5	Reserved
	bit 6	Overcurrent (oC)
	bit 7	Overvoltage (ov)
	bit 8	Heatsink Overheat (oH)
	bit 9	Overheat 1 (oH1)
	bit A	Reserved
	bit B	Overload (oL2)
	bit C - bit F	Reserved

Register No.	Contents	
00C1H	Fault Contents 4	
	bit 0	External Fault at input terminal S3 (EF3)
	bit 1	External Fault at input terminal S4 (EF4)
	bit 2	External Fault at input terminal S5 (EF5)
	bit 3	External Fault at input terminal S6 (EF6)
	bit 4	External Fault at input terminal S7 (EF7)
	bit 5	External Fault at input terminal S8 (EF8)
	bit 6	Cooling Fan Error (Fan)
	bit 7 - bit C	Reserved
	bit D	Digital Operator Connection Fault (oPr)
	bit E	EEPROM Write Error (Err)
bit F	Reserved	
00C2H	Fault Contents 5	
	bit 0	MEMOBUS/Modbus Communication Error (CE)
	bit 1	Option Communication Error (bUS)
	bit 2 - bit 5	Reserved
	bit 6	Option External Fault (EF0)
	bit 7 - bit E	Reserved
	bit F	Hardware Fault (includes of□)
00C3H	Fault Contents 6	
	bit 0 - bit 7	Reserved
	bit 8	MECHATROLINK Watchdog Timer Error (E5)
	bit 9 - bit F	Reserved
00C4H	Fault Contents 7	
	bit 0	Reserved
	bit 1	External Fault 1, input terminal S1 (EF1)
	bit 2	External Fault 2, input terminal S2 (EF2)
	bit 3 - bit 4	Reserved
	bit 5	Current Offset Fault (CoF)
00C5H	Fault Contents 8	
	bit 0	Reserved
	bit 1	Node Setup Fault (nSE)
	bit 2 - bit F	Reserved
00C6H	Fault Contents 9	
	bit 0 - bit 4	Reserved
	bit 5	Power Supply Undervoltage (AUv)
	bit 6	Power Supply Overvoltage (Aov)
	bit 7	Power Supply Frequency Fault (Fdv)
	bit 8	Power Phase Rotation Variation (SrC)
	bit 9	Input Power Supply Fault (PF2)
	bit A	Input Phase Loss 3 (PF3)
	bit B - E	Reserved
	bit F	AC Fuse Blowout (FUA)
00C7H	Reserved	

## C.9 MEMOBUS/Modbus Data Table

Register No.	Contents	
00C8H	Alarm Contents 2	
	bit 0	Undervoltage (Uv)
	bit 1	Overvoltage (ov)
	bit 2	Heatsink Overheat (oH)
	bit 3	Overheat 2 (oH2)
	bit 4 - bit 6	Reserved
	bit 7	Baseblock (bb)
	bit 8	External Fault 3, input terminal S3 (EF3)
	bit 9	External Fault 4, input terminal S4 (EF4)
	bit A	External Fault 5, input terminal S5 (EF5)
	bit B	External Fault 6, input terminal S6 (EF6)
	bit C	External Fault 7, input terminal S7 (EF7)
	bit D	External Fault 8, input terminal S8 (EF8)
	bit E	Cooling Fan Error (Fan)
bit F	Reserved	
00C9H	Alarm Contents 3	
	bit 0 - bit 1	Reserved
	bit 2	Digital Operator Connection Fault (oPr)
	bit 3	MEMOBUS/Modbus Communication Error (CE)
	bit 4	Option Communication Error (bUS)
	bit 5	Serial Communication Transmission Error (CALL)
	bit 6	Reserved
	bit 7	Overload (oL2)
	bit 8	Reserved
	bit 9	Option Card External fault (EF0)
	bit A - bit B	Reserved
	bit C	Serial Communication Transmission Error (CALL)
	bit D - bit E	Reserved
	bit F	MEMOBUS/Modbus Test Mode Fault (SE)
00CAH	Reserved	
00CBH	Alarm Contents 5	
	bit 0	MECHATROLINK Watchdog Timer Error (E5)
	bit 1	MECHATROLINK Station Address Setting Error (AEr)
	bit 2	MECHATROLINK Communication Cycle Setting Error (CyC)
	bit 3	High Current Alarm (HCA)
	bit 4	Cooling Fan Maintenance Time (LT-1)
	bit 5	Soft Charge Bypass Relay Maintenance Time (LT-2)
	bit 6	Reserved
	bit 7	SI-S EEPROM Error (EEP)
	bit 8	External Fault 1 (input terminal S1) (EF1)
	bit 9	External Fault 2 (input terminal S2) (EF2)
	bit A - bit F	Reserved

Register No.	Contents	
00CCH	Alarm Contents 6	
	bit 0 - bit 1	Reserved
	bit 2	Capacitor Maintenance Time (LT-3)
	bit 3 - bit E	Reserved
	bit F	Power Supply Undervoltage (AUv)
00CDH - 00CFH	Reserved	
00D0H	CPF Contents 1	
	bit 0, 1	Reserved
	bit 2	A/D Conversion Error (CPF02)
	bit 3	PWM Data Fault (CPF03)
	bit 4, 5	Reserved
	bit 6	EEPROM Memory Data Error (CPF06)
	bit 7	Terminal Board Connection Error (CPF07)
	bit 8	EEPROM Serial Communications Fault (CPF08)
	bit 9, A	Reserved
	bit B	RAM Fault (CPF11)
	bit C	FLASH Memory Fault (CPF12)
	bit D	Watchdog Circuit Exception (CPF13)
	bit E	Control Circuit Fault (CPF14)
	bit F	Reserved
00D1H	CPF Contents 2	
	bit 0	Clock Fault (CPF16)
	bit 1	Timing Fault (CPF17)
	bit 2	Control Circuit Fault (CPF18)
	bit 3	Control Circuit Fault (CPF19)
	bit 4	Hardware fault at power up (CPF20)
	bit 5	Hardware fault at communication start up (CPF21)
	bit 6	A/D Conversion Fault (CPF22)
	bit 7	PWM Feedback Fault (CPF23)
	bit 8	Unit Capacity Detect Fault (CPF24)
	bit 9	Terminal board is not properly connected. (CPF25)
	bit A	ASIC BB Circuit Error (CPF26)
	bit B	ASIC PWM Setting Register Error (CPF27)
	bit C	ASIC PWM Pattern Error (CPF28)
	bit D	ASIC On-delay Error (CPF29)
	bit E	ASIC BBON Error (CPF30)
	bit F	ASIC Code Error (CPF31)
00D2H	bit 0	ASIC Start-up Error (CPF32)
	bit 1	Watch-dog Error (CPF33)
	bit 2	ASIC Power/Clock Error (CPF34)
	bit 3	External A/D Unit Error (CPF35)
	bit 4 - 7	Reserved
	bit 8	Control Circuit Error (CPF40)
	bit 9	Control Circuit Error (CPF41)
	bit A	Control Circuit Error (CPF42)
	bit B	Control Circuit Error (CPF43)
	bit C	Control Circuit Error (CPF44)
bit D	Control Circuit Error (CPF45)	
bit E, F	Reserved	
00D3H - 00D7H	Reserved	

## C.9 MEMOBUS/Modbus Data Table

Register No.	Contents	
00D8H	oFA0□ Contents (CN5-A)	
	bit 0	Option Compatibility Error (oFA00)
	bit 1	Option not properly connected (oFA01)
	bit 2	Same type of option card already connected (oFA02)
	bit 3, 4	Reserved
	bit 5	A/D Conversion Error (oFA05)
	bit 6	Option Response Error (oFA06)
	bit 7 - F	Reserved
00D9H	oFA1□ Contents (CN5-A)	
	bit 0	Option RAM Fault (oFA10)
	bit 1	Option Operation Mode Fault (SLMOD) (oFA11)
	bit 2	Unit Receive CRC Error (oFA12)
	bit 3	Unit Receive Frame Error (oFA13)
	bit 4	Unit Receive Abort Error (oFA14)
	bit 5	Option Receive CRC Error (oFA15)
	bit 6	Option Receive Frame Error (oFA16)
	bit 7	Option Receive Abort Error (oFA17)
	bit 8 - F	Reserved
00DAH - 00DBH	Reserved	
00DBH	oFA3□ Contents (CN5-A)	
	bit 0	Communication ID Error (oFA30)
	bit 1	Model Code Error (oFA31)
	bit 2	Sumcheck Error (oFA32)
	bit 3	Communication option timeout waiting for response (oFA33)
	bit 4	MEMOBUS/Modbus Timeout (oFA34)
	bit 5	Unit timeout waiting for response (oFA35)
	bit 6	CI Check Error (oFA36)
	bit 7	Unit timeout waiting for response (oFA37)
	bit 8	Control Command Selection Error (oFA38)
	bit 9	Unit timeout waiting for response (oFA39)
	bit A	Control Response Selection 1 Error (oFA40)
	bit B	Unit timeout waiting for response (oFA41)
	bit C	Control Response Selection 2 Error (oFA42)
	bit D	Control Response Selection Error (oFA43)
bit E, F	Reserved	
00DCH - 00FBH	Reserved	

<1> Communication error contents are saved until the fault is reset.

## ◆ Fault Trace Contents

The table below shows the fault codes that can be read out by MEMOBUS/Modbus commands from the U2-□□ monitor parameters.

**Table C.5 Fault Trace/History Register Contents**

Fault Code	Fault Name	Fault Code	Fault Name
0001H	DC Fuse Blowout (FUd)	0099H	Unit Capacity Detect Fault (CPF24)
0002H	Undervoltage (Uv1)	009AH	Terminal Board is Not Properly Connected. (CPF25)
0003H	Control Power Supply Undervoltage (Uv2)	009BH	ASIC BB Circuit Error (CPF26)
0004H	Soft Charge Circuit Fault (Uv3)	009CH	ASIC PWM Setting Register Error (CPF27)
0005H	IGBT Short Circuit (SC)	009DH	ASIC PWM Pattern Error (CPF28)
0007H	Overcurrent (oC)	009EH	ASIC On-delay Error (CPF29)
0008H	Overvoltage (ov)	009FH	ASIC BBON Error (CPF30)
0009H	Heatsink Overheat (oH)	00A0H	ASIC Code Error (CPF31)
000AH	Overheat 1 (oH1)	00A1H	ASIC Start-up Error (CPF32)
000CH	Overload (oL2)	00A2H	Watch-dog Error (CPF33)
0011H	External Fault at Input Terminal S3 (EF3)	00A3H	ASIC Power/Clock Error (CPF34)
0012H	External Fault at Input Terminal S4 (EF4)	00A4H	External A/D Unit Error (CPF35)
0013H	External Fault at Input Terminal S5 (EF5)	00A9H	Control Circuit Error (CPF40)
0014H	External Fault at Input Terminal S6 (EF6)	00AAH	Control Circuit Error (CPF41)
0015H	External Fault at Input Terminal S7 (EF7)	00ABH	Control Circuit Error (CPF42)
0016H	External Fault at Input Terminal S8 (EF8)	00ACH	Control Circuit Error (CPF43)
001EH	Digital Operator Connection (oPr)	00ADH	Control Circuit Error (CPF44)
001FH	EEPROM Write Error (Err)	00AEH	Control Circuit Error (CPF45)
0021H	MEMOBUS/Modbus Communication Error (CE)	0101H	Option Compatibility Error (oFA00)
0022H	Option Communication Error (bUS)	0102H	Option Not Properly Connected (oFA01)
0027H	Option External Fault (EF0)	0103H	Same Type of Option Card Already Connected (oFA02)
0030H	Hardware Fault (including oF□)	0106H	A/D Conversion Error (oFA05)
0042H	External Fault 1, Input Terminal S1 (EF1)	0107H	Option Response Error (oFA06)
0043H	External Fault 2, Input Terminal S2 (EF2)	0111H	Option RAM Fault (oFA10)
0046H	Current Offset Fault (CoF)	0112H	Option Operation Mode Fault (SLMOD) (oFA11)
0047H	PLC Detection Error 1 (PE1)	0113H	Unit Receive CRC Error (oFA12)
0048H	PLC Detection Error 2 (PE2)	0114H	Unit Receive Frame Error (oFA13)
0052H	Node Setup Fault (nSE)	0115H	Unit Receive Abort Error (oFA14)
0070H	AC Fuse Blowout (FUA)	0116H	Option Receive CRC Error (oFA15)
0083H	A/D Conversion Error (CPF02)	0117H	Option Receive Frame Error (oFA16)
0084H	PWM Data Fault (CPF03)	0118H	Option Receive Abort Error (oFA17)
0087H	EEPROM Memory Data Error (CPF06)	0131H	Communication ID Error (oFA30)
0088H	Terminal Board Connection Error (CPF07)	0132H	Model Code Error (oFA31)
0089H	EEPROM Serial Communication Fault (CPF08)	0133H	Sumcheck Error (oFA32)
008CH	RAM Fault (CPF11)	0134H	Communication Option Timeout Waiting for Response (oFA33)
008DH	Flash Memory Circuit Exception (CPF12)	0135H	MEMOBUS/Modbus Timeout (oFA34)
008EH	Watchdog Circuit Exception (CPF13)	0136H	Unit Timeout Waiting for Response (oFA35)
008FH	Control Circuit Fault (CPF14)	0137H	CI Check Error (oFA36)
0091H	Clock Fault (CPF16)	0138H	Unit Timeout Waiting for Response (oFA37)
0092H	Timing Fault (CPF17)	0139H	Control Command Selection Error (oFA38)
0093H	Control Circuit Fault (CPF18)	013AH	Unit Timeout Waiting for Response (oFA39)
0094H	Control Circuit Fault (CPF19)	013BH	Control Response Selection 1 Error (oFA40)
0095H	Hardware Fault at Power Up (CPF20)	013CH	Unit Timeout Waiting for Response (oFA41)
0096H	Hardware Fault at Communication Start Up (CPF21)	013DH	Control Response Selection 2 Error (oFA42)
0097H	A/D Conversion Fault (CPF22)	013EH	Control Response Selection Error (oFA43)
0098H	PWM Feedback Fault (CPF23)	–	–

**◆ Alarm Register Contents**

The table below shows the alarm codes that can be read out from MEMOBUS/Modbus register 007FH.

**Table C.6 Alarm Register 007FH Contents**

<b>Fault Code</b>	<b>Fault Name</b>	<b>Fault Code</b>	<b>Fault Name</b>
0001H	Undervoltage (Uv)	0020H	MEMOBUS/Modbus Test Mode Fault (SE)
0002H	Overvoltage (ov)	0031H	MECHATROLINK Watchdog Timer Error (E5)
0003H	Heatsink Overheat (oH)	0032H	MECHATROLINK Station Address Setting Error (AEr)
0008H	Baseblock (bb)	0033H	MECHATROLINK Communication Cycle Setting Error (CyC)
0009H	External Fault 3, input terminal S3 (EF3)	0034H	High Current Alarm (HCA)
000AH	External Fault 4, input terminal S4 (EF4)	0035H	Cooling Fan Maintenance Time (LT-1)
000BH	External Fault 5, input terminal S5 (EF5)	0036H	Capacitor Maintenance Time (LT-2)
000CH	External Fault 6, input terminal S6 (EF6)	0038H	SI-S EEPROM Error (EEP)
000DH	External Fault 7, input terminal S7 (EF7)	0039H	External Fault (input terminal S1) (EF1)
000EH	External Fault 8, input terminal S8 (EF8)	003AH	External Fault (input terminal S2) (EF2)
000FH	Cooling Fan Error (Fan)	003FH	PLC Alarm 1 (PA1)
0014H	MEMOBUS/Modbus Communication Error (CE)	0040H	PLC Alarm 2 (PA2)
0015H	Option Communication Error (bUS)	0043H	Soft Charge Bypass Relay Maintenance Time (LT-3)
0018H	Overload (oL2)	006BH	Power Supply Undervoltage Pre-Alarm (PAUv)
001AH	Option Card External Fault (EF0)	006CH	PFDv (Power Supply Frequency Excessive Deviation Pre-alarm)
001DH	Serial Communication Transmission Error (CALL)	–	–



## C.10 Enter Command

When writing parameters to the regenerative unit from the PLC using MEMOBUS/Modbus communication, parameter H5-11 determines whether an Enter command must be issued to enable these parameters. This section describes the types and functions of the Enter commands.

### ◆ Enter Command Types

The regenerative unit supports two types of Enter commands as shown in [Table C.7](#). An Enter command is enabled by writing 0 to register numbers 0900H or 0910H. It is only possible to write to these registers; attempting to read from these registers will cause an error.

**Table C.7 Enter Command Types**

Register No.	Description
0900H	Simultaneously writes data into the EEPROM (non-volatile memory) of the regenerative unit and enables the data in RAM. Parameter changes remain after cycling power.
0910H	Writes data in the RAM only. Parameter changes are lost when the regenerative unit is shut off.

**Note:** The EEPROM can only be written to 100,000 times, so it is recommended to limit the number of times writing to the EEPROM. The Enter command registers are write-only and if these registers are read, the register address will be invalid (Error code: 02H). An Enter command is not required when reference or broadcast data are sent to the regenerative unit.

## C.11 Communication Errors

### ◆ MEMOBUS/Modbus Error Codes

A list of MEMOBUS/Modbus errors appears below.

When an error occurs, remove whatever caused the error and restart communications.

Error Code	Error Name
	Cause
01H	Function Code Error
	Attempted to set a function code from a PLC other than 03H, 08H, and 10H.
02H	Register Number Error
	<ul style="list-style-type: none"> <li>• A register number specified in the command message does not exist.</li> <li>• Attempted to send a broadcast message using other register numbers than 0001H or 0002H.</li> </ul>
03H	Bit Count Error
	<ul style="list-style-type: none"> <li>• Read data or write data is greater than 16 bits. Invalid command message quantity.</li> <li>• In a write message, the “Number of Data Items” contained within the message does not equal twice the amount of data words (i.e., the total of Data 1+ Data 2, etc.).</li> </ul>
21H	Data Setting Error
	<ul style="list-style-type: none"> <li>• Control data or parameter write data is outside the allowable setting range.</li> <li>• Attempted to write a contradictory parameter setting.</li> </ul>
22H	Write Mode Error
	<ul style="list-style-type: none"> <li>• During run, the user attempted to write a parameter that cannot be written to during run.</li> <li>• During an EEPROM memory data error (CPF06), the master attempted to write to a parameter other than A1-00 to A1-05, E1-03, or o2-04.</li> <li>• Attempted to write to read-only data.</li> </ul>
23H	DC Bus Undervoltage Write Error
	During an undervoltage situation, the master attempted to write to parameters that cannot be written to during undervoltage.
24H	Write Error During Parameter Process
	Master attempted writing to the regenerative unit while the regenerative unit was processing parameter data.

### ◆ Slave Not Responding

In the following situations, the slave regenerative unit will ignore the command message sent from the master, and not send a response message:

- When a communications error (overrun, framing, parity, or CRC-16) is detected in the command message.
- When the slave address in the command message and the slave address in the regenerative unit do not match (remember to set the slave address for the regenerative unit using H5-01).
- When the gap between two blocks (8-bit) of a message exceeds 24 bits.
- When the command message data length is invalid.

**Note:** If the slave address specified in the command message is 00H, all slaves execute the write function, but do not return response messages to the master.

## C.12 Self-Diagnostics

The regenerative unit has a built-in self-diagnosing function of the serial communication interface circuits. To perform the self-diagnosis function, use the following procedure.

**DANGER! Electrical Shock Hazard.** Do not connect or disconnect wiring while the power is on. Failure to comply will result in death or serious injury. Before servicing, disconnect all power to the equipment. The internal capacitor remains charged even after the power supply is turned off. The charge indicator LED will extinguish when the DC bus voltage is below 50 Vdc. To prevent electric shock, wait at least one minute after all indicators are OFF and measure the DC bus voltage level to confirm safe level.

1. Turn on the power to the regenerative unit.
2. Note the present terminal S6 function selection setting (H1-06) and set it for the communications test mode (H1-06 = 67).
3. Turn off the power to the regenerative unit.
4. With the power off, wire the regenerative unit as shown in **Figure C.7**, connecting terminals R+ and S+, R- and S-, and S6 and SC.

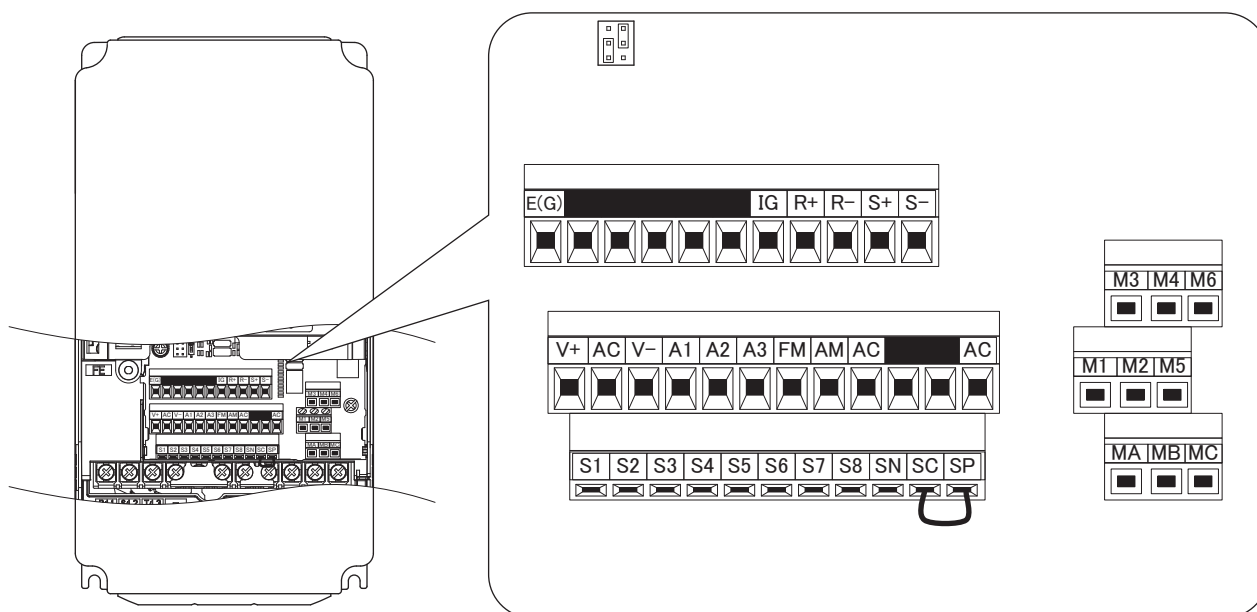

**Figure C.7 Terminal Connections for Communication Self-Diagnostics**

5. Set jumper S3 to source mode (internal power supply).
6. Turn the power to the regenerative unit back on.
7. During normal operation, the regenerative unit will display “Pass” to indicate that the communications test mode is operating normally.  
When a fault occurs, the regenerative unit will display “CE” on the keypad display.
8. Turn off the power supply.
9. Remove the wire jumpers from terminal R+, R-, S+, S-, and S6-SC. Reset jumper S3 to its original position and set terminal S6 to its original function.
10. Return to normal operation.



# Appendix: D

## Standards Compliance

---

This appendix explains the guidelines and criteria for maintaining CE and UL standards.

<b>D.1</b>	<b>SECTION SAFETY</b> .....	<b>186</b>
<b>D.2</b>	<b>EUROPEAN STANDARDS</b> .....	<b>188</b>
<b>D.3</b>	<b>UL STANDARDS</b> .....	<b>191</b>

## D.1 Section Safety

### WARNING

#### Electrical Shock Hazard

**Do not operate equipment with covers removed.**

Failure to comply could result in death or serious injury.

The diagrams in this section may show regenerative units without covers or safety shields to show details. Be sure to reinstall covers or shields before operating the regenerative units and run the regenerative units according to the instructions described in this manual.

**Do not connect or disconnect wiring while the power is on.**

Failure to comply will result in death or serious injury.

**Always ground the motor-side grounding terminal.**

Improper equipment grounding could result in death or serious injury by contacting the motor case.

**Do not touch any terminals before the capacitors have fully discharged.**

Failure to comply could result in death or serious injury.

Before wiring terminals, disconnect all power to the equipment. The internal capacitor remains charged even after the power supply is turned off. After shutting off the power, wait for at least the amount of time specified on the regenerative unit before touching any components.

**Do not allow unqualified personnel to perform work on the regenerative unit.**

Failure to comply could result in death or serious injury.

Installation, maintenance, inspection, and servicing must be performed only by authorized personnel familiar with installation, adjustment, and maintenance of regenerative units.

**Do not perform work on the regenerative unit while wearing loose clothing, jewelry, or lack of eye protection.**

Failure to comply could result in death or serious injury.

Remove all metal objects such as watches and rings, secure loose clothing, and wear eye protection before beginning work on the regenerative unit.

**Do not remove covers or touch circuit boards while the power is on.**

Failure to comply could result in death or serious injury.

#### Fire Hazard

**Tighten all terminal screws to the specified tightening torque.**

Loose electrical connections could result in death or serious injury by fire due to overheating of electrical connections.

**Do not use an improper voltage source.**

Failure to comply could result in death or serious injury by fire.

Verify that the rated voltage of the regenerative unit matches the voltage of the incoming power supply before applying power.

**Do not use improper combustible materials.**

Failure to comply could result in death or serious injury by fire.

Attach the regenerative unit to metal or other noncombustible material.

**NOTICE**

**Observe proper electrostatic discharge procedures (ESD) when handling the regenerative unit and circuit boards.**

Failure to comply may result in ESD damage to the regenerative unit circuitry.

**Never connect or disconnect the motor from the regenerative unit while the regenerative unit is outputting voltage.**

Improper equipment sequencing could result in damage to the regenerative unit.

**Do not use unshielded cable for control wiring.**

Failure to comply may cause electrical interference resulting in poor system performance. Use shielded twisted-pair wires and ground the shield to the ground terminal of the regenerative unit.

**Do not allow unqualified personnel to use the product.**

Failure to comply could result in damage to the regenerative unit.

**Do not modify the regenerative unit circuitry.**

Failure to comply could result in damage to the regenerative unit and will void warranty.

Yaskawa is not responsible for any modification of the product made by the user. This product must not be modified.

**Check all the wiring to ensure that all connections are correct after installing the regenerative unit and connecting any other devices.**

Failure to comply could result in damage to the regenerative unit.

**If a fuse is open or a Residual Current Device (RCD) is tripped, check the wiring and the selection of the peripheral devices.**

Contact your supplier if the cause cannot be identified after checking the above.

**Do not restart the regenerative unit immediately operate the peripheral devices if a fuse is open or an RCD is tripped.**

Check the wiring and the selection of peripheral devices to identify the cause. Contact your supplier before restarting the regenerative unit or the peripheral devices if the cause cannot be identified.

## D.2 European Standards



Figure D.1 CE Mark

The CE mark indicates compliance with European safety and environmental regulations. It is required for engaging in business and commerce in Europe.

European standards include the Machinery Directive for machine manufacturers, the Low Voltage Directive for electronics manufacturers, and the EMC guidelines for controlling electrical noise.

This regenerative unit displays the CE mark based on the EMC guidelines and the Low Voltage Directive.

- Low Voltage Directive: 2006/95/EC
- EMC Guidelines: 2004/108/EC

Devices used in combination with this regenerative unit must also be CE certified and display the CE mark. When using regenerative unit displaying the CE mark in combination with other devices, it is ultimately the responsibility of the user to ensure compliance with CE standards. After setting up the device, verify that conditions meet European standards.

### ◆ CE Low Voltage Directive Compliance

This regenerative unit has been tested according to European standard IEC 61800-5-1, and it fully complies with the Low Voltage Directive.

To comply with the Low Voltage Directive, be sure to meet the following conditions when combining this regenerative unit with other devices:

#### ■ Area of Use

Do not use regenerative unit in areas with pollution higher than severity 2 and overvoltage category 3 in accordance with IEC 664.

#### ■ Standard Configuration Devices

Install appropriate standard configuration devices to the input side to protect regenerative unit wiring and prevent other secondary damage. Select input fuses according to [Table D.1](#).

Refer to [Power Ratings on page 134](#) for details on the regenerative unit Input Current and Rated Output Current.

**NOTICE:** If a fuse is open or a Residual Current Device (RCD) is tripped, check the wiring and the selection of peripheral devices to identify the cause. Contact Yaskawa before restarting the regenerative unit or the peripheral devices if the cause cannot be identified.

Table D.1 Recommended Standard Configuration Devices

Model	Three Phase Input Fuse					Three Phase Input AC Reactor (3%L)		Three Phase Input AC Reactor (1%L)	
	Fuse		Holder			SHANGHAI EAGTOP ELECTRONIC TECHNOLOGY CO LTD		Sao Electric Corporation	
	Model	Ratings	Model	Ratings	Manufacturer	Model	Ratings	Model	Ratings
<b>200 V Class</b>									
<b>2□03P5</b>	350GH-20ULTC	380 V, 20 A	HT4017	400 V, 75 A	HINODE	ACL-0020-EISC-9353BBH	264 V, 20 A, 0.53 mH	300-057-271	264 V, 15 A, 0.31 mH
<b>2□0005</b>	350GH-25ULTC	380 V, 25 A	HT4017	400 V, 75 A	HINODE	ACL-0030-EISC-9353BBH	264 V, 30 A, 0.35 mH	300-057-271	264V, 15 A, 0.31 mH
<b>2□0007</b>	350GH-32ULTC	380 V, 32 A	HT4017	400 V, 75 A	HINODE	ACL-0040-EISC-9353BBH	264 V, 40 A, 0.265 mH	300-057-272	264 V, 20 A, 0.15 mH
<b>2□0010</b>	350GH-50ULTC	380 V, 50 A	HT4017	400 V, 75 A	HINODE	ACL-0060-EISC-9353BBH	264 V, 60 A, 0.18 mH	300-057-273	264 V, 40 A, 0.1 mH



Model	Three Phase Input Fuse					Three Phase Input AC Reactor (3%L)		Three Phase Input AC Reactor (1%L)	
	Fuse		Holder			SHANGHAI EAGTOP ELECTRONIC TECHNOLOGY CO LTD		Sao Electric Corporation	
	Model	Ratings	Model	Ratings	Manufacturer	Model	Ratings	Model	Ratings
2□0014	350GH-63ULTC	380 V, 63 A	HT4017	400 V, 75 A	HINODE	ACL-0080-EISC-9353BBH	264 V, 80 A, 0.13 mH	300-057-273	264 V, 40 A, 0.1 mH
2□0017	350GH-80ULTC	380 V, 80 A	HT4017	400 V, 75 A	HINODE	ACL-0090-EISC-9353BBH	264 V, 90 A, 0.12 mH	300-057-274	264 V, 50 A, 0.06 mH
2□0020	350GH-100ULTC	380 V, 100 A	HT4017	400 V, 75 A	HINODE	ACL-0120-EISC-9353BBH	264 V, 120 A, 0.09 mH	300-057-275	264 V, 60 A, 0.05 mH
2□0028	350GH-125ULTC	380 V, 125 A	HT5723	400 V, 100 A	HINODE	ACL-0160-EISC-9353BBH	264 V, 160 A, 0.07 mH	300-057-276	264 V, 80 A, 0.04 mH
2□0035	350GH-160ULTC	380 V, 160 A	HT5723	400 V, 100 A	HINODE	ACL-0200-EISC-9353AH	264 V, 200 A, 0.05 mH	300-057-277	264 V, 100 A, 0.03 mH
2□0053	350GH-200ULTC	380 V, 200 A	HT5723	400 V, 100 A	HINODE	ACL-0280-EISC-9353BBH	264 V, 280 A, 0.038 mH	300-056-829	264 V, 153 A, 0.02 mH
2□0073	170M2620	700 V, 350 A	170H1007	1000 V, 400 A	BUSSMANN	ACL-0360-EISC-9353BBH	264 V, 360 A, 0.026 mH	300-056-830	264 V, 209 A, 0.015 mH
2□0105	170M3021	700 V, 500 A	170H3003	1000 V, 630 A	BUSSMANN	ACL-0500-EISC-9353BBH	264 V, 500 A, 0.02 mH	300-056-831	264 V, 306 A, 0.01 mH
<b>400 V Class</b>									
4□03P5	660GH-16ULTC	660 V, 16 A	HT6017	700 V, 75 A	HINODE	ACL-0010-EISC-9353ABH	528 V, 10 A, 2.2 mH	300-057-278	528 V, 7.5 A, 1.2 mH
4□0005	660GH-16ULTC	660 V, 16 A	HT6017	700 V, 75 A	HINODE	ACL-0015-EISC-9353ABH	528 V, 15 A, 1.42 mH	300-057-278	528 V, 7.5 A, 1.2 mH
4□0007	660GH-16ULTC	660 V, 16 A	HT6017	700 V, 75 A	HINODE	ACL-0020-EISC-9353ABH	528 V, 20 A, 1.06 mH	300-057-279	528 V, 10 A, 0.6 mH
4□0010	660GH-25ULTC	660 V, 25 A	HT6017	700 V, 75 A	HINODE	ACL-0030-EISC-9353ABH	528 V, 30 A, 0.7 mH	300-057-280	528 V, 15 A, 0.4 mH
4□0014	660GH-40ULTC	660 V, 40 A	HT6017	700 V, 75 A	HINODE	ACL-0040-EISC-9353ABH	528 V, 40 A, 0.53 mH	300-057-281	528 V, 25 A, 0.3 mH
4□0017	660GH-40ULTC	660 V, 40 A	HT6017	700 V, 75 A	HINODE	ACL-0050-EISC-9353ABH	528 V, 50 A, 0.42 mH	300-057-281	528 V, 25 A, 0.3 mH
4□0020	660GH-50ULTC	660 V, 50 A	HT6017	700 V, 75 A	HINODE	ACL-0060-EISC-9353ABH	528 V, 60 A, 0.36 mH	300-057-282	528 V, 30 A, 0.2 mH
4□0028	660GH-63ULTC	660 V, 63 A	HT6017	700 V, 75 A	HINODE	ACL-0080-EISC-9353ABH	528 V, 80 A, 0.26 mH	300-057-283	528 V, 40 A, 0.15 mH
4□0035	660GH-80ULTC	660 V, 80 A	HT6017	700 V, 75 A	HINODE	ACL-0090-EISC-9353ABH	528 V, 90 A, 0.24 mH	300-057-284	528 V, 50 A, 0.12 mH
4□0043	660GH-100ULTC	660 V, 100 A	HT6017	700 V, 75 A	HINODE	ACL-0120-EISC-9353BH	528 V, 120 A, 0.18 mH	300-057-285	528 V, 60 A, 0.10 mH
4□0053	660GH-125ULTC	660 V, 125 A	HT7723	800 V, 100 A	HINODE	ACL-0150-EISC-9353ABH	528 V, 150 A, 0.15 mH	300-057-286	528 V, 75 A, 0.08 mH
4□0073	660GH-160ULTC	660 V, 160 A	HT7723	800 V, 100 A	HINODE	ACL-0200-EISC-9353ABH	528 V, 200 A, 0.11 mH	300-057-287	528 V, 100 A, 0.06 mH
4□0105	170M1371	700 V, 250 A	170H1007	1000 V, 400 A	BUSSMANN	ACL-0250-EISC-9353ABH	528 V, 250 A, 0.09 mH	300-056-832	528 V, 161 A, 0.04 mH

## D.2 European Standards

Model	Three Phase Input Fuse					Three Phase Input AC Reactor (3%L)		Three Phase Input AC Reactor (1%L)	
	Fuse		Holder			SHANGHAI EAGTOP ELECTRONIC TECHNOLOGY CO LTD		Sao Electric Corporation	
	Model	Ratings	Model	Ratings	Manufacturer	Model	Ratings	Model	Ratings
4□0150	170M2620	700 V, 350 A	170H1007	1000 V, 400 A	BUSSMANN	ACL-0330-EISC-9353ABH	528 V, 330 A, 0.06 mH	300-056-833	528 V, 237 A, 0.03 mH
4□0210	170M3021	700 V, 500 A	170H3003	1000 V, 630 A	BUSSMANN	ACL-0490-EISC-9353ABH	528 V, 490 A, 0.04 mH	300-056-834	528 V, 326 A, 0.02 mH
4□0300	170M4016	700 V, 630 A	170H3003	1000 V, 630 A	BUSSMANN	ACL-0660-EISC-9353ABH	528 V, 660 A, 0.03 mH	300-056-835	528 V, 466 A, 0.013 mH

### ■ Grounding

The regenerative unit is designed to be used in T-N (grounded neutral point) networks. If installing the regenerative unit in other types of grounded systems, contact your Yaskawa representative for instructions.

### ■ Guarding Against Harmful Materials

When installing IP00/Open Type enclosure regenerative units and standard configuration devices, use an enclosure that prevents foreign material from entering the regenerative unit from above or below.

### ◆ EMC Guidelines Compliance

This regenerative unit is tested according to European standards IEC/EN 61800-3: 2004, and complies with the European standards IEC/EN 12015 (requires an optional AC reactor) and IEC/EN 12016.

### ■ EMC Filter Installation

The EMC filter must be installed using this installation method to ensure compliance with EMC guidelines. Refer to the Quick Start Guide or Technical Manual of the drive which the regenerative unit is connected. Refer to [Figure D.2](#) for the wiring details.

#### Connection Diagram

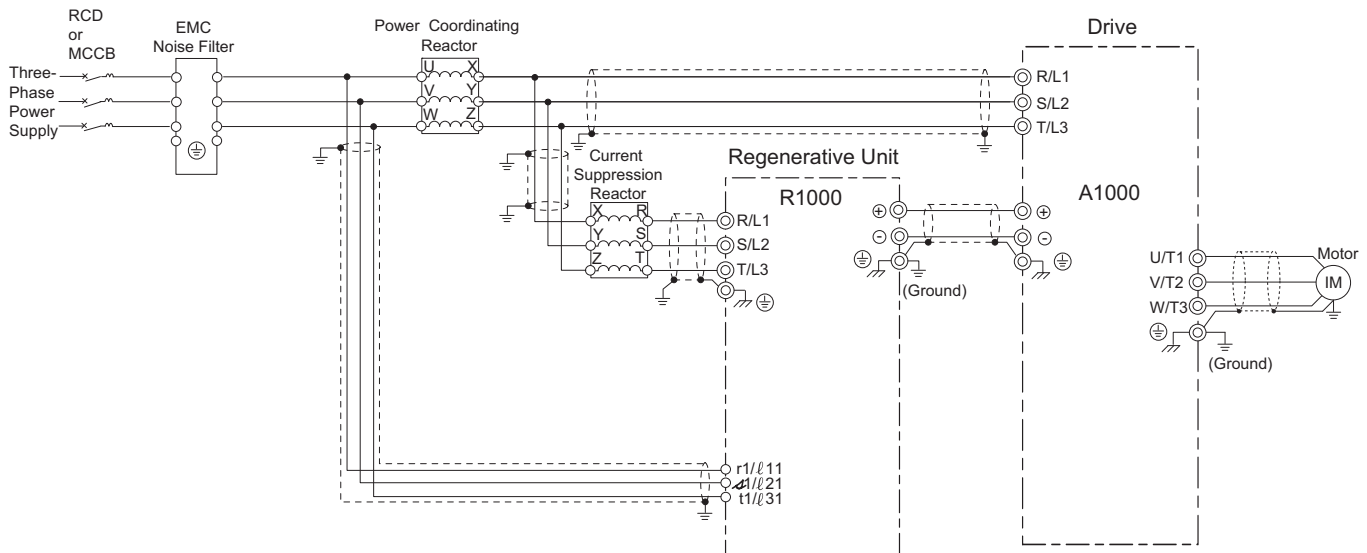

Figure D.2 Wiring Diagram for EMC (Models 2A03P5 to 2A0105, 4A03P5 to 4A0300)

## D.3 UL Standards

### ◆ UL Standards

The RU mark applies to products in the United States and Canada and it means that UL has performed product testing and evaluation and determined that their stringent standards for product safety have been met. For a product to receive UL certification, all components inside that product must also receive UL certification.



Figure D.3 RU Mark

### ◆ UL Standards Compliance

This regenerative unit is tested in accordance with UL standard UL508C and complies with UL requirements. To ensure continued compliance when using this regenerative unit in combination with other equipment, meet the following conditions:

#### ■ Conditions of Acceptability

1. The Current Suppression Reactor shall be installed on the input of R1000 Series device.
2. The R1000 (open type) device and its peripherals shall be installed in a suitable enclosure in the end use.
3. The R1000 Series of Power Regenerative devices shall be connected to a VFD which incorporates Solid State Short Circuit Protection Circuitry and was found to comply with the High Fault Current Short Circuit Test without additional testing when:
  - a) The R1000 series uses solid state short circuit protection circuitry for compliance with the Short Circuit Test, Section 45 of UL508C, 3rd edition; and
  - b) The solid state short circuit protection circuitry is used in accordance with 45.1.3 of UL508C, 3rd edition.
4. Optional Power Coordinating Reactor may be specified in the end use application. An equivalent, UL Listed or Recognized, Power Coordinating Reactor can be substituted in place of Yaskawa's Power Coordinating Reactor provided the minimum impedance is 3%, calculated as follows:
 
$$L = [0.03 \times E \text{ (Drive Input Rated Voltage)}] / [\sqrt{3} \times 2 \times \pi \times f \text{ (Input Rated Frequency)} \times I \text{ (System Rated Current)}]$$
5. AC Input Fuse shall be connected to the input side of the Current Suppression Reactor.

#### ■ Installation Area

Do not install the regenerative unit to an area greater than pollution degree 2 (UL standard).

#### ■ Ambient Temperature

IP00/Open Type enclosure: -10°C to +50°C

IP20/NEMA Type 1 enclosure: -10°C to +40°C

#### ■ Main Circuit Terminal Wiring

Yaskawa recommends using closed-loop crimp terminals on all regenerative unit models. To maintain UL/cUL or CSA approval, UL Listed or CSA Certified closed-loop crimp terminals are specifically required when wiring the regenerative unit main circuit terminals on models 2A0035 to 2A0105, 4A0035 to 4A0300. Use only the tools recommended by the terminal manufacturer for crimping. Refer to [Closed-Loop Crimp Terminal Recommendations on page 196](#) for closed-loop crimp terminal recommendations. The wire gauges listed in the following tables are Yaskawa recommendations. Refer to local codes for proper wire gauge selections.

**Note:** The mark ⊕ indicates the terminals for protective ground connection as defined in IEC/EN 60417-5019.

Grounding impedance:

200 V: 100 Ω or less

400 V: 10 Ω or less

#### Wire Gauges and Tightening Torques

**Table D.2 Wire Gauge and Torque Specifications (Three-Phase 200 V Class)**

Model	Terminal	Recommended Gauge AWG, kcmil	Applicable Gauge AWG, kcmil	Screw Size	Tightening Torque N·m (lb·in.)
2A03P5	R/L1, S/L2, T/L3	12	12 to 6	M4	2.1 to 2.3 (18.6 to 20.4)
	⊖, ⊕	12	12 to 6	M4	2.1 to 2.3 (18.6 to 20.4)
	r1/ℓ11, s1/ℓ21, t1/ℓ31	14	14	M3.5	0.8 to 1.0 (7.1 to 8.9)
	⊕	12	12 to 8	M5	2.0 to 2.5 (17.7 to 22.1)
2A0005	R/L1, S/L2, T/L3	12	12 to 6	M4	2.1 to 2.3 (18.6 to 20.4)
	⊖, ⊕	10	10 to 6	M4	2.1 to 2.3 (18.6 to 20.4)
	r1/ℓ11, s1/ℓ21, t1/ℓ31	14	14	M3.5	0.8 to 1.0 (7.1 to 8.9)
	⊕	12	12 to 8	M5	2.0 to 2.5 (17.7 to 22.1)
2A0007	R/L1, S/L2, T/L3	12	12 to 6	M4	2.1 to 2.3 (18.6 to 20.4)
	⊖, ⊕	10	10 to 6	M4	2.1 to 2.3 (18.6 to 20.4)
	r1/ℓ11, s1/ℓ21, t1/ℓ31	14	14	M3.5	0.8 to 1.0 (7.1 to 8.9)
	⊕	10	10 to 8	M5	2.0 to 2.5 (17.7 to 22.1)
2A0010	R/L1, S/L2, T/L3	10	10 to 6	M4	2.1 to 2.3 (18.6 to 20.4)
	⊖, ⊕	6	6	M4	2.1 to 2.3 (18.6 to 20.4)
	r1/ℓ11, s1/ℓ21, t1/ℓ31	14	14	M3.5	0.8 to 1.0 (7.1 to 8.9)
	⊕	8	8 to 6	M6	2.0 to 2.5 (17.7 to 22.1)
2A0014	R/L1, S/L2, T/L3	8	8 to 6	M4	2.1 to 2.3 (18.6 to 20.4)
	⊖, ⊕	6	6	M4	2.1 to 2.3 (18.6 to 20.4)
	r1/ℓ11, s1/ℓ21, t1/ℓ31	14	14	M3.5	0.8 to 1.0 (7.1 to 8.9)
	⊕	8	8 to 6	M6	2.0 to 2.5 (17.7 to 22.1)

Model	Terminal	Recommended Gauge AWG, kcmil	Applicable Gauge AWG, kcmil	Screw Size	Tightening Torque N·m (lb·in.)
2A0017	R/L1, S/L2, T/L3	8	8 to 1	M6	3.6 to 4.0 (31.9 to 35.4)
	⊖, ⊕	4	4 to 1	M6	3.6 to 4.0 (31.9 to 35.4)
	r1/ℓ11, s1/ℓ21, t1/ℓ31	14	14	M3.5	0.8 to 1.0 (7.1 to 8.9)
	⊕	8	8 to 4	M6	5.4 to 6.0 (47.8 to 53.1)
2A0020	R/L1, S/L2, T/L3	6	6 to 1	M6	3.6 to 4.0 (31.9 to 35.4)
	⊖, ⊕	4	4 to 1	M6	3.6 to 4.0 (31.9 to 35.4)
	r1/ℓ11, s1/ℓ21, t1/ℓ31	14	14	M3.5	0.8 to 1.0 (7.1 to 8.9)
	⊕	6	6 to 4	M6	5.4 to 6.0 (47.8 to 53.1)
2A0028	R/L1, S/L2, T/L3	4	4 to 1	M6	3.6 to 4.0 (31.9 to 35.4)
	⊖, ⊕	2	2 to 1	M6	3.6 to 4.0 (31.9 to 35.4)
	r1/ℓ11, s1/ℓ21, t1/ℓ31	14	14	M3.5	0.8 to 1.0 (7.1 to 8.9)
	⊕	6	6 to 4	M6	5.4 to 6.0 (47.8 to 53.1)
2A0035	R/L1, S/L2, T/L3	2	2 to 2/0	M8	5.4 to 6.0 (47.8 to 53.1)
	⊖, ⊕	1/0	1/0 to 2/0	M8	5.4 to 6.0 (47.8 to 53.1)
	r1/ℓ11, s1/ℓ21, t1/ℓ31	14	14 to 10	M4	1.1 to 1.2 (9.7 to 10.6)
	⊕	4	4	M8	9.0 to 11.0 (79.7 to 97.4)
2A0053	R/L1, S/L2, T/L3	2/0	2/0 to 250	M8	13.5 to 15.0 (119.5 to 132.8)
	⊖, ⊕	4/0	4/0 to 250	M8	13.5 to 15.0 (119.5 to 132.8)
	r1/ℓ11, s1/ℓ21, t1/ℓ31	14	14 to 10	M4	1.1 to 1.2 (9.7 to 10.6)
	⊕	3	3 to 2	M10	18.0 to 23.0 (159 to 204)
2A0073	R/L1, S/L2, T/L3	1/0 × 2P	1/0 to 300	M12	32.0 to 40.0 (283 to 354)
	⊖, ⊕	3/0 × 2P	3/0 to 300	M12	32.0 to 40.0 (283 to 354)
	r1/ℓ11, s1/ℓ21, t1/ℓ31	14	14 to 10	M4	1.1 to 1.2 (9.7 to 10.6)
	⊕	1/0	1/0 to 300	M12	32.0 to 40.0 (283 to 354)
2A0105	R/L1, S/L2, T/L3	3/0 × 2P	3/0 to 600	M12	32.0 to 40.0 (283 to 354)
	⊖, ⊕	300 × 2P	300 to 600	M12	32.0 to 40.0 (283 to 354)
	r1/ℓ11, s1/ℓ21, t1/ℓ31	14	14 to 10	M4	1.1 to 1.2 (9.7 to 10.6)
	⊕	1/0	1/0 to 300	M12	32.0 to 40.0 (283 to 354)

Table D.3 Wire Gauge and Torque Specifications (Three-Phase 400 V Class)

Model	Terminal	Recommended Gauge AWG, kcmil	Applicable Gauge AWG, kcmil	Screw Size	Tightening Torque N·m (lb·in.)
4A03P5	R/L1, S/L2, T/L3	10	10 to 6	M4	2.1 to 2.3 (18.6 to 20.4)
	⊖, ⊕	12	12 to 6	M4	2.1 to 2.3 (18.6 to 20.4)
	r1/ℓ11, s1/ℓ21, t1/ℓ31	14	14	M3.5	0.8 to 1.0 (7.1 to 8.9)
	⊕	12	12 to 10	M5	2.0 to 2.5 (17.7 to 22.1)
4A0005	R/L1, S/L2, T/L3	10	10 to 6	M4	2.1 to 2.3 (18.6 to 20.4)
	⊖, ⊕	12	12 to 6	M4	2.1 to 2.3 (18.6 to 20.4)
	r1/ℓ11, s1/ℓ21, t1/ℓ31	14	14	M3.5	0.8 to 1.0 (7.1 to 8.9)
	⊕	12	12 to 10	M5	2.0 to 2.5 (17.7 to 22.1)
4A0007	R/L1, S/L2, T/L3	12	12 to 6	M4	2.1 to 2.3 (18.6 to 20.4)
	⊖, ⊕	12	12 to 6	M4	2.1 to 2.3 (18.6 to 20.4)
	r1/ℓ11, s1/ℓ21, t1/ℓ31	14	14	M3.5	0.8 to 1.0 (7.1 to 8.9)
	⊕	10	10	M5	2.0 to 2.5 (17.7 to 22.1)
4A0010	R/L1, S/L2, T/L3	12	12 to 6	M4	2.1 to 2.3 (18.6 to 20.4)
	⊖, ⊕	10	10 to 6	M4	2.1 to 2.3 (18.6 to 20.4)
	r1/ℓ11, s1/ℓ21, t1/ℓ31	14	14	M3.5	0.8 to 1.0 (7.1 to 8.9)
	⊕	10	10 to 6	M6	2.0 to 2.5 (17.7 to 22.1)
4A0014	R/L1, S/L2, T/L3	10	10 to 6	M4	2.1 to 2.3 (18.6 to 20.4)
	⊖, ⊕	10	10 to 6	M4	2.1 to 2.3 (18.6 to 20.4)
	r1/ℓ11, s1/ℓ21, t1/ℓ31	14	14	M3.5	0.8 to 1.0 (7.1 to 8.9)
	⊕	10	10 to 6	M6	2.0 to 2.5 (17.7 to 22.1)
4A0017	R/L1, S/L2, T/L3	10	10 to 1	M6	3.6 to 4.0 (31.9 to 35.4)
	⊖, ⊕	6	6 to 1	M6	3.6 to 4.0 (31.9 to 35.4)
	r1/ℓ11, s1/ℓ21, t1/ℓ31	14	14	M3.5	0.8 to 1.0 (7.1 to 8.9)
	⊕	8	8 to 6	M6	5.4 to 6.0 (47.8 to 53.1)
4A0020	R/L1, S/L2, T/L3	8	8 to 1	M6	3.6 to 4.0 (31.9 to 35.4)
	⊖, ⊕	6	6 to 1	M6	3.6 to 4.0 (31.9 to 35.4)
	r1/ℓ11, s1/ℓ21, t1/ℓ31	14	14	M3.5	0.8 to 1.0 (7.1 to 8.9)
	⊕	8	8 to 6	M6	5.4 to 6.0 (47.8 to 53.1)

Model	Terminal	Recommended Gauge AWG, kcmil	Applicable Gauge AWG, kcmil	Screw Size	Tightening Torque N·m (lb·in.)
4A0028	R/L1, S/L2, T/L3	8	8 to 1	M6	3.6 to 4.0 (31.9 to 35.4)
	⊖, ⊕	6	6 to 1	M6	3.6 to 4.0 (31.9 to 35.4)
	r1/ℓ11, s1/ℓ21, t1/ℓ31	14	14	M3.5	0.8 to 1.0 (7.1 to 8.9)
	⊕	8	8 to 6	M6	5.4 to 6.0 (47.8 to 53.1)
4A0035	R/L1, S/L2, T/L3	6	6 to 2/0	M8	5.4 to 6.0 (47.8 to 53.1)
	⊖, ⊕	3	3 to 2/0	M8	5.4 to 6.0 (47.8 to 53.1)
	r1/ℓ11, s1/ℓ21, t1/ℓ31	14	14 to 10	M4	1.1 to 1.2 (9.7 to 10.6)
	⊕	6	6	M8	9.0 to 11.0 (79.7 to 97.4)
4A0043	R/L1, S/L2, T/L3	4	4 to 2/0	M8	5.4 to 6.0 (47.8 to 53.1)
	⊖, ⊕	2	2 to 2/0	M8	5.4 to 6.0 (47.8 to 53.1)
	r1/ℓ11, s1/ℓ21, t1/ℓ31	14	14 to 10	M4	1.1 to 1.2 (9.7 to 10.6)
	⊕	6	6	M8	9.0 to 11.0 (79.7 to 97.4)
4A0053	R/L1, S/L2, T/L3	4	4 to 2/0	M8	5.4 to 6.0 (47.8 to 53.1)
	⊖, ⊕	2	2 to 2/0	M8	5.4 to 6.0 (47.8 to 53.1)
	r1/ℓ11, s1/ℓ21, t1/ℓ31	14	14 to 10	M4	1.1 to 1.2 (9.7 to 10.6)
	⊕	6	6 to 4	M10	18.0 to 23.0 (159 to 204)
4A0073	R/L1, S/L2, T/L3	2	2 to 2/0	M8	5.4 to 6.0 (47.8 to 53.1)
	⊖, ⊕	1/0	1/0 to 2/0	M8	5.4 to 6.0 (47.8 to 53.1)
	r1/ℓ11, s1/ℓ21, t1/ℓ31	14	14 to 10	M4	1.1 to 1.2 (9.7 to 10.6)
	⊕	4	4	M10	18.0 to 23.0 (159 to 204)
4A0105	R/L1, S/L2, T/L3	2/0	2/0 to 300	M10	18.0 to 23.0 (159 to 204)
	⊖, ⊕	4/0	4/0 to 300	M10	18.0 to 23.0 (159 to 204)
	r1/ℓ11, s1/ℓ21, t1/ℓ31	14	14 to 10	M4	1.1 to 1.2 (9.7 to 10.6)
	⊕	1	1 to 300	M10	18.0 to 23.0 (159 to 204)
4A0150	R/L1, S/L2, T/L3	250	250 to 300	M12	32.0 to 40.0 (283 to 354)
	⊖, ⊕	3/0 × 2P	3/0 to 600	M12	32.0 to 40.0 (283 to 354)
	r1/ℓ11, s1/ℓ21, t1/ℓ31	14	14 to 10	M4	1.1 to 1.2 (9.7 to 10.6)
	⊕	1/0	1/0 to 300	M12	32.0 to 40.0 (283 to 354)

### D.3 UL Standards

Model	Terminal	Recommended Gauge AWG, kcmil	Applicable Gauge AWG, kcmil	Screw Size	Tightening Torque N·m (lb·in.)
4A0210	R/L1, S/L2, T/L3	3/0 × 2P	3/0 to 600	M10	18.0 to 23.0 (159 to 204)
	⊖, ⊕	4/0 × 2P	4/0 to 600	M10	18.0 to 23.0 (159 to 204)
	r1/ℓ11, ⚡1/ℓ21, t1/ℓ31	14	14 to 10	M4	1.1 to 1.2 (9.7 to 10.6)
	⊕	2/0	2/0 to 350	M10	18.0 to 23.0 (159 to 204)
4A0300	R/L1, S/L2, T/L3	250 × 2P	250 to 600	M12	32.0 to 40.0 (283 to 354)
	⊖, ⊕	400 × 2P	400 to 600	M12	32.0 to 40.0 (283 to 354)
	r1/ℓ11, ⚡1/ℓ21, t1/ℓ31	14	14 to 10	M4	1.1 to 1.2 (9.7 to 10.6)
	⊕	4/0	4/0 to 350	M12	32.0 to 40.0 (283 to 354)

#### Closed-Loop Crimp Terminal Recommendations

Yaskawa recommends UL Listed or CSA Certified crimp terminals made by JST and Tokyo DIP (or equivalent) for the insulation cap. **Table D.4** matches the wire gauges and terminal screw sizes with Yaskawa-recommended crimp terminals, tools, and insulation caps. Refer to the appropriate Wire Gauge and Torque Specifications table for the wire gauge and screw size for your regenerative unit model. Place orders with a Yaskawa representative or the Yaskawa sales department. The closed-loop crimp terminal sizes and values listed in **Table D.4** are Yaskawa recommendations. Wire gauge values shown in **Table D.4** are the recommended values. Refer to local codes for proper selections.

**Table D.4 Closed-Loop Crimp Terminal Size**

Model	Wire Gauge (AWG, kcmil)		Screw Size	Crimp Terminal Model Number	Tool		Insulation Cap Model No.	Code <†>
	R/L1,S/L2,T/L3	⊖, ⊕			Machine No.	Die Jaw		
<b>200 V Class</b>								
2A03P5	12		M4	R5.5-4	YA-4	AD-900	TP-005	100-054-029
	10			R5.5-4	YA-4	AD-900	TP-005	100-054-029
	8			8-4	YA-4	AD-901	TP-008	100-054-031
	6			14-NK4	YA-4	AD-902	TP-014	100-054-033
2A0005	12	–	M4	R5.5-4	YA-4	AD-900	TP-005	100-054-029
	10	–		R5.5-4	YA-4	AD-900	TP-005	100-054-029
	8	–		8-4	YA-4	AD-901	TP-008	100-054-031
	6	–		14-NK4	YA-4	AD-902	TP-014	100-054-033
2A0007	12	–	M4	R5.5-4	YA-4	AD-900	TP-005	100-054-029
	10	–		R5.5-4	YA-4	AD-900	TP-005	100-054-029
	8	–		8-4	YA-4	AD-901	TP-008	100-054-031
	6	–		14-NK4	YA-4	AD-902	TP-014	100-054-033
2A0010	10	–	M4	R5.5-4	YA-4	AD-900	TP-005	100-054-029
	8	–		8-4	YA-4	AD-901	TP-008	100-054-031
	6	–		14-NK4	YA-4	AD-902	TP-014	100-054-033
2A0014	8	–	M4	8-4	YA-4	AD-901	TP-008	100-054-031
	6	6		14-NK4	YA-4	AD-902	TP-014	100-054-033
2A0017	8	–	M6	R8-6	YA-4	AD-901	TP-008	100-092-620
	6	–		R14-6	YA-4	AD-902	TP-014	100-051-261
	4	–		R22-6	YA-5	AD-953	TP-022	100-051-262
	3	–		38-6	YA-5	AD-954	TP-038	100-092-577
	2	–		38-6	YA-5	AD-954	TP-038	100-092-577
	1	–		60-6	YA-5	AD-955	TP-060	100-092-578



Model	Wire Gauge (AWG, kcmil)		Screw Size	Crimp Terminal Model Number	Tool		Insulation Cap Model No.	Code <?>
	R/L1,S/L2,T/L3	⊖, ⊕			Machine No.	Die Jaw		
2A0020	6	–	M6	R14-6	YA-4	AD-902	TP-014	100-051-261
	4			R22-6	YA-5	AD-953	TP-022	100-051-262
	3			38-6	YA-5	AD-954	TP-038	100-092-577
	2			38-6	YA-5	AD-954	TP-038	100-092-577
	1			60-6	YA-5	AD-955	TP-060	100-092-578
2A0028	4	–	M6	R22-6	YA-5	AD-953	TP-022	100-051-262
	3	–		38-6	YA-5	AD-954	TP-038	100-092-577
	2			38-6	YA-5	AD-954	TP-038	100-092-577
	1			60-6	YA-5	AD-955	TP-060	100-092-578
2A0035	2	–	M8	R38-8	YA-5	AD-954	TP-038	100-051-264
	1	–		R60-8	YA-5	AD-955	TP-060	100-051-265
	1/0			R60-8	YA-5	AD-955	TP-060	100-051-265
	2/0			80-8	YF-1 YET-300-1	TD-323 TD-312	TP-080	100-092-579
2A0053	2/0	–	M8	80-8	YF-1 YET-300-1	TD-323 TD-312	TP-080	100-092-579
	3/0	–		80-8	YF-1 YET-300-1	TD-323 TD-312	TP-080	100-092-579
	4/0			100-8	YF-1 YET-300-1	TD-324 TD-312	TP-100	100-068-032
	250			150-8	YF-1 YET-300-1	TD-325 TD-313	TP-150	100-113-129
2A0073	1/0 × 2P	–	M12	R60-12	YA-5	AD-955	TP-060	100-066-160
	2/0 × 2P	–		80-L12	YF-1 YET-300-1	TD-323 TD-312	TP-080	100-051-558
	3/0 × 2P			80-L12	YF-1 YET-300-1	TD-323 TD-312	TP-080	100-051-558
	4/0	4/0 × 2P		R100-12	YF-1 YET-300-1	TD-324 TD-312	TP-100	100-051-560
	250	250 × 2P		150-L12	YF-1 YET-300-1	TD-325 TD-313	TP-150	100-051-562
	300			150-L12	YF-1 YET-300-1	TD-325 TD-313	TP-150	100-051-562
2A0105	3/0 × 2P	–	M12	80-L12	YF-1 YET-300-1	TD-323 TD-312	TP-080	100-051-558
	4/0 × 2P			100-L12	YF-1 YET-300-1	TD-324 TD-312	TP-100	100-051-560
	250 × 2P			150-L12	YF-1 YET-300-1	TD-325 TD-313	TP-150	100-051-562
	300 × 2P			150-L12	YF-1 YET-300-1	TD-325 TD-313	TP-150	100-051-562
	350	350 × 2P		200-L12	YF-1 YET-300-1	TD-327 TD-314	TP-200	100-051-564
	400	400 × 2P		200-L12	YF-1 YET-300-1	TD-327 TD-314	TP-200	100-051-564
	500	500 × 2P		325-12	YF-1 YET-300-1	TD-328 TD-315	TP-325	100-051-277
	600			325-12	YF-1 YET-300-1	TD-328 TD-315	TP-325	100-051-277
<b>400 V Class</b>								
4A03P5	–	12	M4	R5.5-4	YA-4	AD-900	TP-005	100-054-029
	10			R5.5-4	YA-4	AD-900	TP-005	100-054-029
	8			8-4	YA-4	AD-901	TP-008	100-054-031
	6			14-NK4	YA-4	AD-902	TP-014	100-054-033

### D.3 UL Standards

Model	Wire Gauge (AWG, kcmil)		Screw Size	Crimp Terminal Model Number	Tool		Insulation Cap Model No.	Code <†>
	R/L1,S/L2,T/L3	⊖, ⊕			Machine No.	Die Jaw		
4A0005	–	12	M4	R5.5-4	YA-4	AD-900	TP-005	100-054-029
	10			R5.5-4	YA-4	AD-900	TP-005	100-054-029
	8			8-4	YA-4	AD-901	TP-008	100-054-031
	6			14-NK4	YA-4	AD-902	TP-014	100-054-033
4A0007	12		M4	R5.5-4	YA-4	AD-900	TP-005	100-054-029
	10			R5.5-4	YA-4	AD-900	TP-005	100-054-029
	8			8-4	YA-4	AD-901	TP-008	100-054-031
	6			14-NK4	YA-4	AD-902	TP-014	100-054-033
4A0010	12	–	M4	R5.5-4	YA-4	AD-900	TP-005	100-054-029
	10			R5.5-4	YA-4	AD-900	TP-005	100-054-029
	8			8-4	YA-4	AD-901	TP-008	100-054-031
	6			14-NK4	YA-4	AD-902	TP-014	100-054-033
4A0014	10		M4	R5.5-4	YA-4	AD-900	TP-005	100-054-029
	8			8-4	YA-4	AD-901	TP-008	100-054-031
	6			14-NK4	YA-4	AD-902	TP-014	100-054-033
4A0017	10	–	M6	R5.5-6	YA-4	AD-900	TP-005	100-068-029
	8	–		R8-6	YA-4	AD-901	TP-008	100-092-620
	6			R14-6	YA-4	AD-902	TP-014	100-051-261
	4			R22-6	YA-5	AD-953	TP-022	100-051-262
	3			38-6	YA-5	AD-954	TP-038	100-092-577
	2			38-6	YA-5	AD-954	TP-038	100-092-577
	1			60-6	YA-5	AD-955	TP-060	100-092-578
4A0020	8	–	M6	R8-6	YA-4	AD-901	TP-008	100-092-620
	6			R14-6	YA-4	AD-902	TP-014	100-051-261
	4			R22-6	YA-5	AD-953	TP-022	100-051-262
	3			38-6	YA-5	AD-954	TP-038	100-092-577
	2			38-6	YA-5	AD-954	TP-038	100-092-577
	1			60-6	YA-5	AD-955	TP-060	100-092-578
4A0028	8	–	M6	R8-6	YA-4	AD-901	TP-008	100-092-620
	6			R14-6	YA-4	AD-902	TP-014	100-051-261
	4			R22-6	YA-5	AD-953	TP-022	100-051-262
	3			38-6	YA-5	AD-954	TP-038	100-092-577
	2			38-6	YA-5	AD-954	TP-038	100-092-577
	1			60-6	YA-5	AD-955	TP-060	100-092-578
4A0035	6	–	M8	R14-8	YA-4	AD-902	TP-014	100-051-035
	4			R22-8	YA-5	AD-953	TP-022	100-051-263
	3			R38-8	YA-5	AD-954	TP-038	100-051-264
	2			R38-8	YA-5	AD-954	TP-038	100-051-264
	1			R60-8	YA-5	AD-955	TP-060	100-051-265
	1/0			R60-8	YA-5	AD-955	TP-060	100-051-265
	2/0			80-8	YF-1 YET-300-1	TD-323 TD-312	TP-080	100-092-579
4A0043	4	–	M8	R22-8	YA-5	AD-953	TP-022	100-051-263
	3	–		R38-8	YA-5	AD-954	TP-038	100-051-264
	2			R38-8	YA-5	AD-954	TP-038	100-051-264
	1			R60-8	YA-5	AD-955	TP-060	100-051-265
	1/0			R60-8	YA-5	AD-955	TP-060	100-051-265
	2/0			80-8	YF-1 YET-300-1	TD-323 TD-312	TP-080	100-092-579

Model	Wire Gauge (AWG, kcmil)		Screw Size	Crimp Terminal Model Number	Tool		Insulation Cap Model No.	Code <T>
	R/L1,S/L2,T/L3	⊖, ⊕			Machine No.	Die Jaw		
4A0053	4	–	M8	R22-8	YA-5	AD-953	TP-022	100-051-263
	3	–		R38-8	YA-5	AD-954	TP-038	100-051-264
	2	–		R38-8	YA-5	AD-954	TP-038	100-051-264
	1	–		R60-8	YA-5	AD-955	TP-060	100-051-265
	1/0	–		R60-8	YA-5	AD-955	TP-060	100-051-265
	2/0	–		80-8	YF-1 YET-300-1	TD-323 TD-312	TP-080	100-092-579
4A0073	2	–	M8	R38-8	YA-5	AD-954	TP-038	100-051-264
	1	–		R60-8	YA-5	AD-955	TP-060	100-051-265
	1/0	–		R60-8	YA-5	AD-955	TP-060	100-051-265
	2/0	–		80-8	YF-1 YET-300-1	TD-323 TD-312	TP-080	100-092-579
4A0105	2/0	–	M10	80-L10	YF-1 YET-300-1	TD-323 TD-312	TP-080	100-051-557
	3/0	–		80-L10	YF-1 YET-300-1	TD-323 TD-312	TP-080	100-051-557
	4/0	–		R100-10	YF-1 YET-300-1	TD-324 TD-312	TP-100	100-051-559
	250	–		R150-10	YF-1 YET-300-1	TD-325 TD-313	TP-150	100-051-272
	300	–		R150-10	YF-1 YET-300-1	TD-325 TD-313	TP-150	100-051-272
4A0150	–	3/0 × 2P	M12	80-L12	YF-1 YET-300-1	TD-323 TD-312	TP-080	100-051-558
	–	4/0 × 2P		100-L12	YF-1 YET-300-1	TD-324 TD-312	TP-100	100-051-560
	250	250 × 2P		150-L12	YF-1 YET-300-1	TD-325 TD-313	TP-150	100-051-562
	300	300 × 2P		150-L12	YF-1 YET-300-1	TD-325 TD-313	TP-150	100-051-562
	–	350 × 2P		200-L12	YF-1 YET-300-1	TD-327 TD-314	TP-200	100-051-564
	–	400		200-L12	YF-1 YET-300-1	TD-327 TD-314	TP-200	100-051-564
	–	500		325-12	YF-1 YET-300-1	TD-328 TD-315	TP-325	100-051-277
	–	600		325-12	YF-1 YET-300-1	TD-328 TD-315	TP-325	100-051-277
4A0210	3/0 × 2P	–	M12	80-L12	YF-1 YET-300-1	TD-323 TD-312	TP-080	100-051-558
	4/0 × 2P	–		100-L12	YF-1 YET-300-1	TD-324 TD-312	TP-100	100-051-560
	250 × 2P	–		150-L12	YF-1 YET-300-1	TD-325 TD-313	TP-150	100-051-562
	300 × 2P	–		150-L12	YF-1 YET-300-1	TD-325 TD-313	TP-150	100-051-562
	350 × 2P	–		200-L12	YF-1 YET-300-1	TD-327 TD-314	TP-200	100-051-564
	400	400 × 2P		200-L12	YF-1 YET-300-1	TD-327 TD-314	TP-200	100-051-564
	500	500 × 2P		325-12	YF-1 YET-300-1	TD-328 TD-315	TP-325	100-051-277
	600	600 × 2P		325-12	YF-1 YET-300-1	TD-328 TD-315	TP-325	100-051-277

## D.3 UL Standards

Model	Wire Gauge (AWG, kcmil)		Screw Size	Crimp Terminal Model Number	Tool		Insulation Cap Model No.	Code <1>
	R/L1,S/L2,T/L3	⊖, ⊕			Machine No.	Die Jaw		
4A0300	250 × 2P	–	M12	150-L12	YF-1 YET-300-1	TD-325 TD-313	TP-150	100-051-562
	300 × 2P	–		150-L12	YF-1 YET-300-1	TD-325 TD-313	TP-150	100-051-562
	350 × 2P	–		200-L12	YF-1 YET-300-1	TD-327 TD-314	TP-200	100-051-564
	400 × 2P	–		200-L12	YF-1 YET-300-1	TD-327 TD-314	TP-200	100-051-564
	500 × 2P	–		325-12	YF-1 YET-300-1	TD-328 TD-315	TP-325	100-051-277
	600 × 2P	–		325-12	YF-1 YET-300-1	TD-328 TD-315	TP-325	100-051-277

<1> Codes refer to a set of three crimp terminals and three insulation caps. Prepare input and output wiring using two sets for each connection.  
 Example 1: Model 4A0105 with 300 kcmil for both input and output require one set for input terminals and one set for output terminals, so the user should order two sets of [100-051-272].  
 Example 2: Model 4A0210 with 300 kcmil × 2P for both input and output require two sets for input terminals and two sets for output terminals, so the user should order four sets of [100-051-562].

**Note:** Use crimp insulated terminals or insulated shrink tubing for wiring connections. Wires should have a continuous maximum allowable temperature of 75°C 600 Vac UL-approved vinyl-sheathed insulation.

Model	Wire Gauge (AWG, kcmil)	Screw Size	Crimp Terminal Model Number	Tool		Insulation Cap Model No.	Code
	r1/l11, s1/l21, t1/l31			Machine No.	Die Jaw		
2A03P5 to 2A0028, 4A03P5 to 4A0028	14	M3.5	R2-3.5	YA-4	AD-900	TP-003	100-106-516
2A0035 to 2A0105, 4A0035 to 4A0300	14	M4	R2-4	YA-4	AD-900	TP-003	100-106-517

### ◆ Power Coordinating Reactor/Current Suppression Reactor

To conform to UL508C, connect the power coordinating reactor to the input side of the drive, input fuses, and the current suppression reactor to the input side of the regenerative unit. Refer to [Standard Configuration Devices on page 188](#) for details.

### ◆ Installing Standard Configuration Devices

**NOTICE:** If a fuse is open or a Residual Current Device (RCD) is tripped, check the wiring and the selection of the peripheral devices. Check the wiring and the selection of peripheral devices to identify the cause. Contact Yaskawa before restarting the regenerative unit or the peripheral devices if the cause cannot be identified.

#### ■ Recommended Standard Configuration Devices

Yaskawa recommends installing standard configuration devices to maintain compliance with UL508C. Refer to [Standard Configuration Devices on page 188](#) for details.

#### ■ Low Voltage Wiring for Control Circuit Terminals

Wire low voltage wires with NEC Class 1 circuit conductors. Refer to national state or local codes for wiring. The external power supply shall be a CSA certified or cUL Listed Class 2 power source only or equivalent.

**Table D.5 Control Circuit Terminal Power Supply**

Input / Output	Terminal Signal	Power Supply Specifications
Multi-function digital inputs	S1, S2, S3, S4, S5, S6, S7, S8, SC	Use the internal LVLC power supply of the regenerative unit. Use class 2 for external power supply.
Multi function analog inputs	+V, -V, A1, A2, A3, AC	

#### ■ Regenerative Unit Short-Circuit Rating

This regenerative unit is suitable for use on a circuit capable of delivering not more than 100,000 RMS symmetrical amperes, 240 Vac for 200 V class regenerative units and 480 Vac for 400 V class regenerative units, when protected by fuses as specified on the [Table D.6](#).

Connect the regenerative unit to an AC drive which has built-in semiconductor short-circuit protection and conforms to UL short-circuit test.

### ◆ Precautionary Notes on External Heatsink (IP00/Open Type enclosure)

When using an external heatsink, UL compliance requires that exposed capacitors in the main circuit are covered to prevent injury to surrounding personnel.

The portion of the external heatsink that projects out can either be protected with the enclosure, or with the appropriate capacitor cover after regenerative unit installation is complete. Use the table below to match regenerative unit models and capacitor cover. Capacitor covers can be ordered from a Yaskawa representative or directly from the Yaskawa sales department. The table below lists available capacitor covers.

**Table D.6 Capacitor Cover**

Model	Code Number	Figure
2A0035	100-061-274	<i>Figure D.4</i>
2A0053	100-061-275	
2A0073	100-061-277	
2A0105	100-061-278	
4A0035	100-061-274	
4A0043	100-061-274	
4A0053	100-061-275	
4A0073	100-061-275	
4A0105	100-061-277	
4A0150	100-061-277	
4A0210	100-061-278	
4A0300	100-061-278	

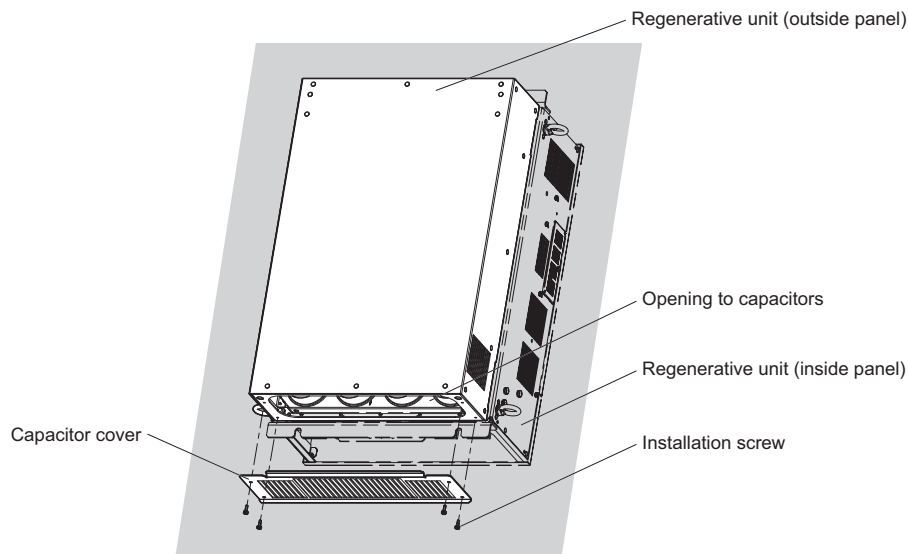

**Figure D.4 Capacitor Cover**

## Revision History

The revision dates and the numbers of the revised manuals appear on the bottom of the back cover.

MANUAL NO. SIEP C710656 09B

Published in Japan January 2015 14-2 ◇

◇ — Revision number  
 — Date of original publication  
 — Date of publication

Date of Publication	Revision Number	Section	Revised Content
January 2015	◇	All	Revision: Reviewed and corrected the entire documentation.
		5.2	Revision: Cause and possible solutions for oC and ov
		D.2	Revision: Standard Configuration Devices
		D.3	Addition: Conditions of Acceptability Revision: Installing Standard Configuration Devices
		Back cover	Revision: Address
February 2014	—	—	First Edition.

# YASKAWA R1000 Series

## Power Regenerative Unit

### Technical Manual

---

**YASKAWA EUROPE GmbH**

185, Hauptstraße, Eschborn, 65760, Germany  
Phone: +49 (0)6196 569 300 Fax: +49 (0)6196 569 398  
E-mail: [info@yaskawa.eu.com](mailto:info@yaskawa.eu.com) Internet: <http://www.yaskawa.eu.com>

**DRIVE CENTER (INVERTER PLANT)**

2-13-1, Nishimiyaichi, Yukuhashi, Fukuoka, 824-8511, Japan  
Phone: +81 (0)930 25 3844 Fax: +81 (0)930 25 4369  
Internet: <http://www.yaskawa.co.jp>

**YASKAWA AMERICA, INC.**

2121, Norman Drive South, Waukegan, IL 60085, U.S.A.  
Phone: +1 800 YASKAWA (927-5292) or +1 847 887 7000 Fax: +1 847 887 7310  
Internet: <http://www.yaskawa.com>



YASKAWA ELECTRIC CORPORATION

In the event that the end user of this product is to be the military and said product is to be employed in any weapons systems or the manufacture thereof, the export will fall under the relevant regulations as stipulated in the Foreign Exchange and Foreign Trade Regulations. Therefore, be sure to follow all procedures and submit all relevant documentation according to any and all rules, regulations and laws that may apply.

Specifications are subject to change without notice for ongoing product modifications and improvements.

© 2014-2015 YASKAWA ELECTRIC CORPORATION. All rights reserved.

MANUAL NO. SIEP C710656 09B

Published in Japan January 2015 14-2   
14-10-7\_YEU